



Operation Manual

Multifunctional Road Sweeper

CF-3310 & CF-3310F



Dear Customer:

Congratulations on your purchase of CityFox products!

The multifunctional road sweeper CF-3310 can clean the cleaning area in an extremely flexible way.

In order to make your multifunctional road sweeper CF-3310 play its best performance, please read this manual carefully before using it.

If you do not read it carefully, it will cause damage to the machine and even personal injury.



Safety

In order to maximize the safety of users and the environment, the multifunctional road sweeper CF-3310 is equipped with various devices. You need to pay special attention to the content in "1.1 Security". This machine can only be inspected and repaired by professionals.

The multifunctional road sweeper CF-3310 is designed only for professionals. When the product is delivered, the user will receive comprehensive training to become a qualified operator.

Do not lend the machine to anyone who has not received comprehensive training and has not read this manual carefully.

The operation manual should be an indispensable accessory for this machine. When the machine is sold, this manual must be delivered at the same time.



Caveat

Some clauses in this manual carry this mark, indicating that extra care should be taken in these areas to avoid personal injury or damage to the machine and accessories. The sign also indicates where special attention should be paid.

Rights reserved

Serpark Makine Sanayi Ve Dis Ticaret Ltd. regards continuous improvement as a policy, so we reserve the right to change specifications and equipment at any time without notice. Serpark Makine Sanayi Ve Dis Ticaret Ltd. does not assume any responsibility for errors or omissions in the operation manual.

contact us

If you have any questions about the CityFox Multifunctional Road Sweeper CF-3310, please contact Serpark Makine Sanayi Ve Dis Ticaret Ltd. immediately.

Sincere regards!

Multifunctional road sweeper CF-3310

It is a multi-functional device, flexible and changeable, with superior strength. The multifunctional road sweeper CF-3310 brings you high performance and best mobility. It is equipped with articulated steering, which is easy to operate, safe and reliable, and comfortable in operation. There are no less than 5 kinds of accessory devices! Professional-quality accessory

Foreword

devices are not only easy to operate, but also improve the function of the equipment.

Multi-purpose practical equipment

If you need a multi-purpose device and accessory device, the multifunctional road sweeper CF-3310 will provide you with a flexible three-in-one solution, and its accessory device is very easy to replace. It can be equipped with a variety of tailor-made accessory devices-fully integrated and specifically designed for the device-to ensure excellent completion of various tasks.

Mainly used for three types of tasks:

- Pavement suction sweeping
- High pressure cleaning
- Snow push snow



Comfortable

The multifunctional road sweeper CF-3310 is an outdoor practical equipment, equipped with an air-conditioned panoramic cab. The adjustable suspension shock-absorbing seat makes the operator's work more comfortable. All operation control devices are located in a reasonable position and are convenient for operators to use. The multifunctional road sweeper CF-3310 is an investment that can stand the test of time-it can work 24 hours a day and has low operating costs.

Foreword

Serpark Multifunctional Road Sweeper

CF-3310 brings you the most ideal cleaning effect. Where CF-3310 passes, whether it is the city center, sidewalks or alleys, everything is as clean as new. The unique vacuum suction and sweeping principle ensures extremely high suction and sweeping performance and energy-saving operation. Both brushes of CF-3310 can be controlled independently. This maneuverability allows the operator to easily suck and

sweep the sidewalks, surrounding areas of street facilities and parking lots. The operator can adjust the suction and sweep speed and the amount of water sprayed. Through the unique ballast-free system, the pressure of the sweeping brush on the ground can be adjusted according to the usage, and the wear of the sweeping brush can be reduced to ensure low-cost operation and achieve a spotless cleaning effect.

The sweeping width of the system can reach 2.4 meters while absorbing all the garbage.

Features

- **Front sweeping brush that can move independently**
- **Discharge height of recovery bin 1.55m**
- **External vacuum hose**

The brush is made of high wear-resistant steel wire and nylon wire

- **The width of the suction port is 740mm, which can pick up larger garbage**
- **The straw is directly connected to the recycling box**





- The recycling bin is made of aluminum alloy
- Equipped with high pressure water gun
- Optional snow push and snow rolls

1.1 Safety

 **Prevent rollover**
Do not operate the device in a place that is easy to slip, tilt or roll over. Do not drive your car on a slope with a slope of more than 10° . (figure 1)

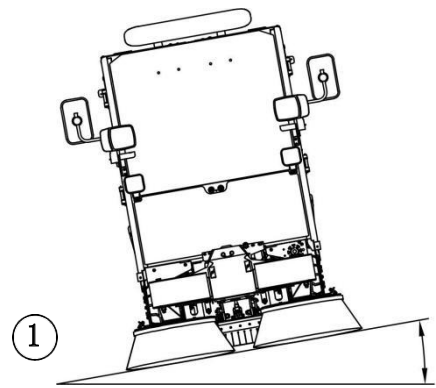
The multifunctional road sweeper CF-3310 is very small and easy to drive in the city center. The driver should not turn sharply, so as not to affect the stability of the vehicle



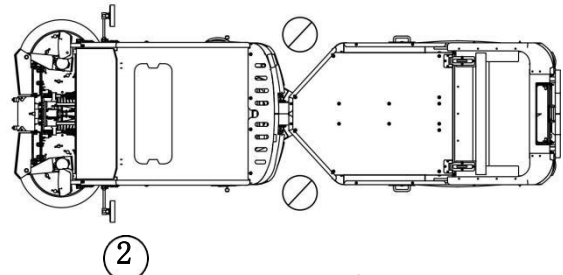

 **When using the device, make sure that there are no people standing around the body**
Before using the device, make sure that no one is around the body to avoid personal injury. (figure 2)

 **Do not breathe in exhaust gas**
The exhaust gas is harmful to the body and may even in a closed space, the exhaust gas must be discharged through the exhaust hose can be used. Otherwise, doors and windows must be opened to allow fresh air to enter.



 **Avoid crushing**
Prevent anyone from putting hands and feet close to the moving parts or hinged parts of the vehicle.

 **Empty the recycling bin**
Before emptying the recycling bin, make sure:
A) Stop the equipment on a level road without tilting.
B) Raise the handbrake.
C) There is enough space to open the back cover.

 **Other hazards**
In addition to the above, the use of the multifunctional road sweeper RG-8240 in other environments and situations may also be dangerous.



Exhaust pipe

Do not touch the exhaust pipe when the machine is in operation to avoid burns.

(figure 1)



Hydraulic components

Please note: The hydraulic components may heat up when the machine is in use.



Accessory installation/removal

When installing or removing accessories, be sure to do it on a flat and stable road.



Note!

Do not loosen the screws on the hydraulic oil tank, otherwise the warranty of the entire hydraulic circuit will be invalid. (figure 2)



Please handle potentially dangerous products with care

- Do not smoke when refueling.
- Do not spill diesel fuel on the engine, mechanical parts or vehicle body.
- Brake fluid is extremely harmful and extremely corrosive. Avoid contact with skin and eyes. In case of contact, rinse thoroughly with clean water. Vehicle parts in contact with brake fluid should be rinsed with clean water to prevent corrosion.
- The acid in the battery is extremely harmful and extremely corrosive. Avoid contact with skin and eyes. In case of contact, rinse thoroughly with clean water. All mechanical parts or body parts in contact with the acid in the battery should be thoroughly rinsed with clean water.
- Drain all kinds of fluids (brake fluid, battery fluid, hydraulic oil, diesel oil, lubricating oil and cooling water) used in the vehicle to a suitable place.

Basic Information

Follow the operating instructions

- Please keep an eye on passing vehicles and pedestrians when you work.
- Multifunctional road sweeper CF-3310 belongs to engineering equipment. The equipment should not be used to carry people or cargo
- Can climb the sidewalk with a height of no more than 15 cm, but the speed must be slowed down.
- Remember to pull the parking brake and remove the ignition key when parking.



Safety Bracket



Maintenance

Fujian Ronggong Environmental Protection Machinery Co., Ltd. is not responsible for damages or accidents caused by improper use of equipment or lack of maintenance. If you use non-original parts, or accessory devices or other parts that are not approved by the manufacturer, the warranty will be invalid.

When servicing the engine, raise the rear suspension accessory device to put the safety bracket in place. (Picture 1) Before overhauling the engine, the safety bracket must be fixed!

Only under the premise of ensuring safety, can work around the engine.

Do not put your hands in or close to the running turbo fan.

Please keep a safe distance and wear goggles. (Picture 2 and Picture 3)

Do not perform maintenance while the engine is running. Keep away from the cooling circuit fan. (Figure 4)

Liquid under pressure can sometimes penetrate the skin and cause serious injury.

Before overhauling the system, make sure that the system is not under pressure.

1.2 Accessory device

The design of the multifunctional road sweeper CF-3310 is compatible with the following accessory devices:

Accessory device:

Suction and sweep device-sweeping brush (Picture 1)

Suction and sweep device-recovery box (Figure 2)

Suction and sweep device-suction port (Picture 3)

Recycling box assembly truck (Figure 4)

Snow Rolling Parts (Picture 5)

Push snow pieces (Picture 6)

These accessory devices must be operated in accordance with the instructions in the operating manual. Please follow the instructions to operate the multifunctional sweeper RG-8240 and its accessories.



1.3 Technical data

size:	
Long (with brush/without brush)	4285/4070mm
Wide (with brush/without brush)	1400/1240mm
High (with warning light/without warning light)	2040/1880mm
Wheelbase	2040mm
Ground clearance	200mm
weight:	
Vehicle weight (excluding driver)	2370kg
Maximum Total Mass	3980kg
Allowable load of front axle	1800kg
Allowable load of rear axle	2180kg
Aluminum alloy recycling bin capacity	1500L
Operating temperature:	
temperature range*	From -20°C to +50°C
	From -4° F to 122° F
Tire:	
Tire size	195/75 R16
Tire pressure	4.5bar
Engine:	
Model/Manufacturer	Perkins
model	404D-22
cylinder	4
Displacement	2200cm ³
Engine power	36.3kW
Engine speed at maximum power	2800rpm
Maximum torque	143N.m
Engine speed at maximum torque	1800rpm
For more technical data, please refer to the engine operating manual.	
If you need to operate the multifunctional road sweeper RG-8240 at an ambient temperature below -20° C (-4° F), please consult Fujian Ronggong Environmental Protection Machinery Co., Ltd.	

Fuel oil:	
Diesel oil	
Fuel tank volume	68L
Fuel consumption in operating mode	About 3.2L per hour
Lubrication system:	
Engine lubricant	8L~10L (between the upper and lower scales after adding)
Air filter	Replaceable filter filter
cooling system	Coolant
Electrical System:	
Start the system	Electric start (with glow plug)
generator	12V-65A
battery	12V-85AH
Hydraulic oil:	
Types of	ISO VG 46
Fuel tank capacity	About 60L
Front wheel brake	Hydraulic drum brake
Rear wheel brake	Hydrostatic brake
Water circuit:	
Water tank volume:	300L
Sprinkler pump	4.8bar
Drive:	
Four-wheel drive, hydraulic transmission	
Driving speed	Up to 26km/h
Air conditioning:	
Gas R134a	350g
Oil SP20	80cc
Noise level:	
External noise, at rest	77dB(A)
External noise, while traveling	79dB(A)
Inside the cab, close the window	78dB(A)
Inside the cab, open windows	81dB(A)

Performance parameter:	
Cleaning speed	5-12km/h
Gradeability	≥20%
Sweeping width	1600~2400mm
Cleaning efficiency	≥90%
Cleaning ability	28800m ² /h
Recovery box volume	1500L
Discharge height of recovery bin	1580mm
Dumping angle of recycling bin	≥45°
Inner diameter of main waste straw	180mm
Inner diameter of handheld garbage straw	130mm
Hand-held garbage straw length	3500mm
High pressure water gun:	
Hose reach	10m
Water pressure-maximum	140bar
Rollover protection structure	
According to DG05.SJ.02-2011 "Road Sweeper Test Program" test and meet the requirements.	
Rollover angle	≥20°
Exposure to hazardous substances	
<p>The air inlet contains a filter to prevent the driver from inhaling dust.</p> <p>The cab of this category does not provide protection against harmful substances. The multifunctional road sweeper CF-3310 equipped with this cab cannot be used in an environment containing hazardous substances without protective measures.</p>	
Turning radius:	
Minimum turning radius	3450mm
Operate multifunctional road sweeper CF-3310:	
No other special tools are needed to operate the multifunctional road sweeper CF-3310.	
Note:	
Note: Specifications are subject to change without notice.	

1.4 Cab entrance

The entrance to the cab is on the right side of the cab, use the handle to open the door

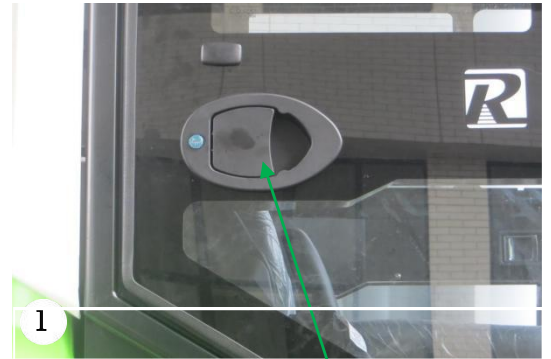

Handle on the door

Just step directly into the cab.



Cab floor

If you need to leave the cab, please use the inner door lock handle to open the door.

There is a similar door on the left. Its operation is the same as that of the right door, and is used as an emergency exit.

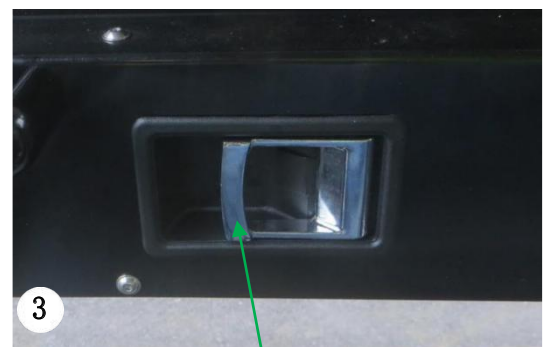

Internal door zipper

1.5 Control device on the dashboard

1) Front dashboard



①

②

③

④

⑤

1. Forward and Reverse gear

2. Safety warning lights

3. Air volume first gear / air volume second gear

4. Air conditioning refrigeration/heating device

5. Alarm light

2) Wiper switch



- 6. Off gear
- 7. First wiper
- 8. Second wiper

Note: The front suspension mechanism will automatically rise when reversing.



Note!

The gear can only be changed after the vehicle has stopped.

3) Left switch lever



- 9. Turn signal lights
- 10. Work light/width indicator light
- 12. High beam

4)Steering column

13. Horn

14. Multifunctional dashboard (see next page)

15. Start switch

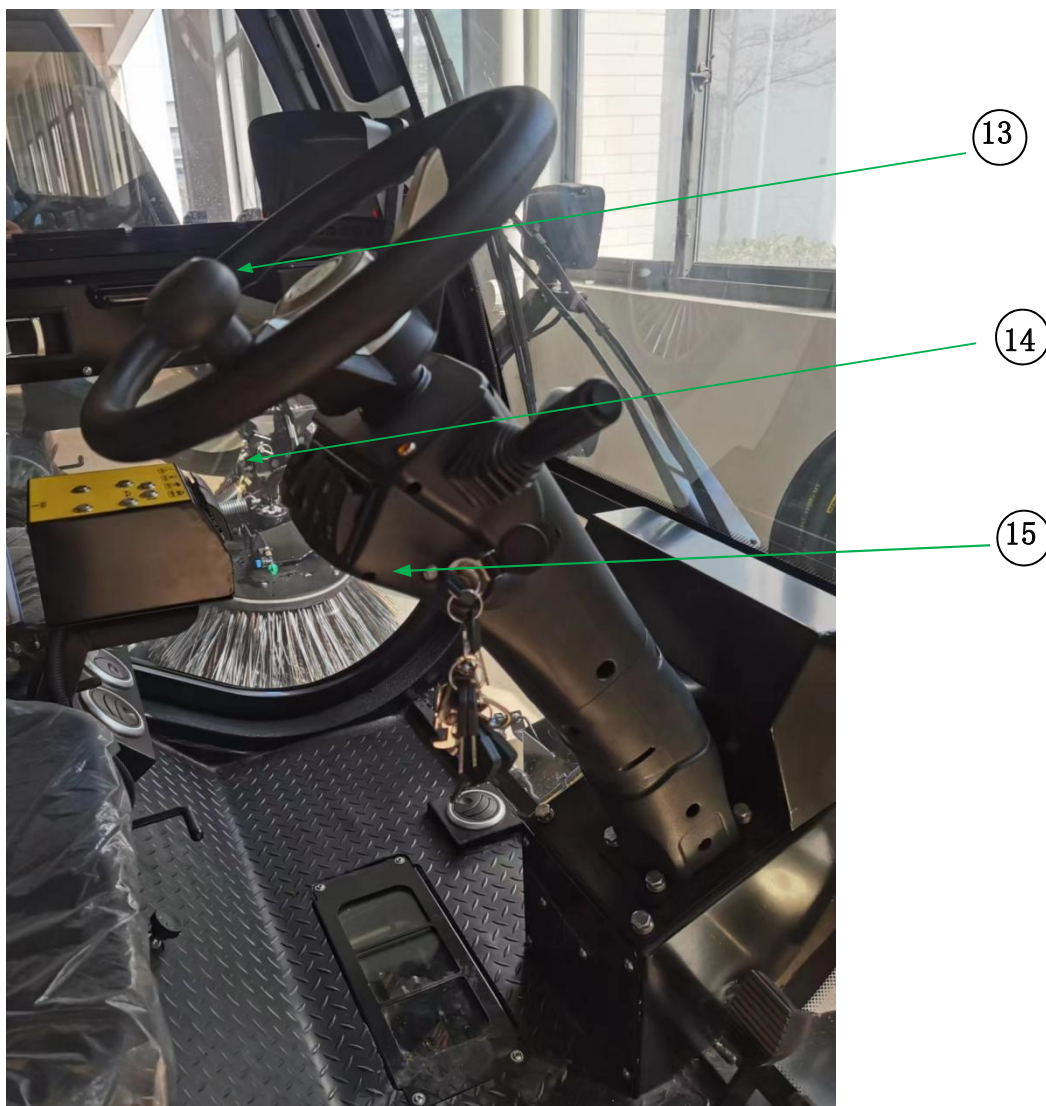

5) Multi-function dashboard



1.Engine water temperature gauge

2.Low water level alarm

3.Parking brake alarm

4.Warm-up indicator

5.Turn right indicator

6.Engine oil pressure alarm

7.Fuel gauge

8.Battery charging indicator (steady on after startup)

*If the light is on, please stop on the side of the road as soon as possible and carry out the inspections described

9. Engine speed

10.Forward/Neutral/Reverse gear

11.Speed

12.Fuel indicator

1.6 Warning lights and monitoring indicators



Note!

If the engine overheats or the hydraulic oil overheats, please contact the after-sales service department.

Do not open the radiator cover when the liquid is under pressure. Otherwise, accidents may occur.

Engine coolant temperature alarm

When the coolant reaches 112° C, the water temperature gauge panel will display 112° C and you will hear a buzzer.

If the water temperature meter shows over 100 °C or hears a buzzing sound during driving, please stop by the road as soon as possible, turn off the engine, and then check the cooling circuit.

The parking brake is tightened

When the parking brake is tightened and the gear is in the driving gear, you will hear a buzzing sound. If you need to drive, please lower the parking brake first.

1.7 Other control devices

Control device around the driver's seat



1. Throttle lever
2. Parking brake
3. Sweep the speed control valve
4. Sweeping nozzle water volume control knob
5. Water volume control knob of suction nozzle
6. The control panel of the accessory device

Basic Information

1) Pedal

1. Brake pedal (Picture 1)

The brake pedal must be used every day

2. Drive the pedal (Picture 1)

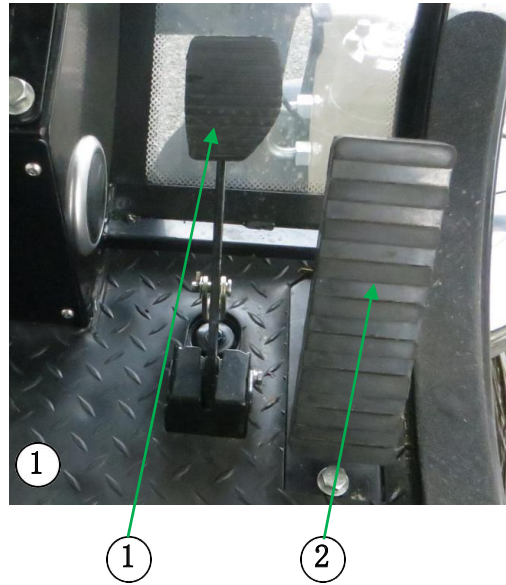

2) Co-pilot seat

1. Air outlet of cold and warm air conditioner (Picture 2)

2. The passenger seat (Picture 2)



3) Co-pilot seat

1. Air outlet of cold and warm air conditioner (Picture 2)

2. The passenger seat (Picture 2)

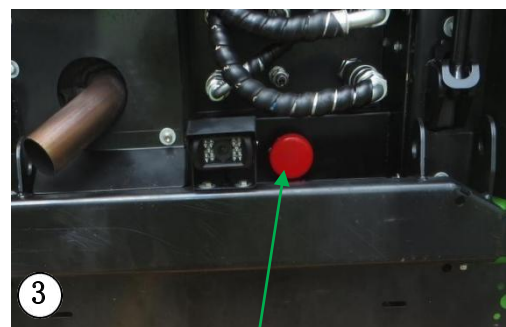

Emergency Stop Button

4) Control panel of accessory device

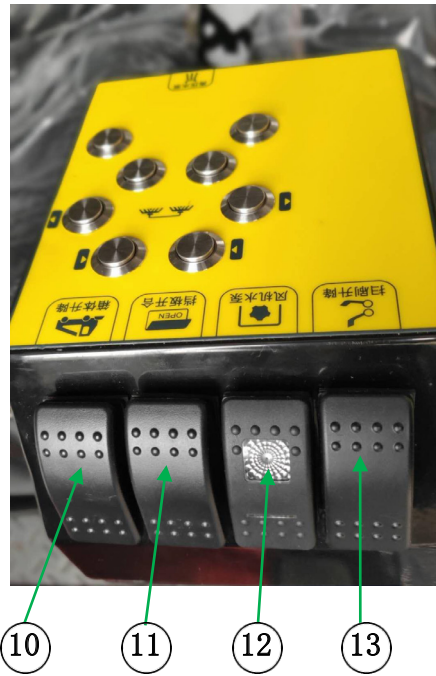

1. Left swipe out
2. Sweep and retract on the left
3. Right swipe indent
4. Right swipe extended
5. The snow piece swings to the left
6. Spare
7. Spare
8. High pressure cleaning function
9. The snow piece swings to the right
10. Empty the recycling bin
11. Opening and closing of the suction vent baffle
12. Turbo fan + sprinkler
13. Lifting of front suspension device

1.8 Fuse

The fuse box is located behind the passenger seat. Remove or dismantle the seat, and remove the electrical parts cover. The middle position of the electrical parts is the fuse position.

(Picture 1+2)The fuse box is located behind the passenger seat. Remove or dismantle the seat, and remove the electrical parts cover. The middle position of the electrical parts is the fuse position.

(Picture 1+2)The fuse box is located behind the passenger seat. Remove or dismantle the seat, and remove the electrical parts cover. The middle position of the electrical parts is the fuse position.

(Picture 1+2)



Cover plate of electrical box

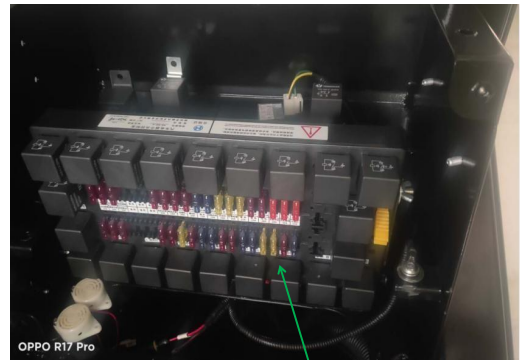

2

Relay

Number	Function	Strength
1	Swipe left	10A
2	Swipe right out	10A
3	Sweep right	10A
4	The box rises	10A
5	Instrument ON	10A
6	Cab lights	10A
7	Brake power	10A
8	Sweep valve	15A
9	Sweep up	15A
10	Spare	20A
11	B+1	20A
12	High beam	20A
13	Brake light	10A
14	Middle	10A
15	Main power	40A
16	Main power	40A
17	Main power	40A
18	Sweep left	10A
19	The box rises	10A
20	Swipe left	10A
21	Fan water pump	10A
22	High pressure pumps	10A
23	compressor	20A
24	Strobe light	10A
25	speaker	15A
26	Total sweeping power	15A
27	flash	10A
28	Instrument power	10A
29	spare	15A
30	spare	15A
31	Fan	20A
32	Middle of pump	20A
33	Handbrake Fengming	10A
34	The width light	15A

1.9 Relay

The relay box is located behind the copilot's seat. Remove or remove the seat and remove the electrical component cover. Both sides of electrical parts are relay positions.

(FIG. 1 + 2)

Serial number	Function
A	Brush the left Saul
B	Left sweeping brush
C	Baffle opening
D	Sweep Y8 delay
E	Sweep the brush rises
F	High beam
G	Brake lights
H	Between front and rear gears (unable to start when in gear)
I	Before and after the block
J	Enclosure rises
K	Reverse lift (lift sweep brush structure)
L	Back light
M	The compressor
N	Flashing lights
O	Fan
P	Middle of pump (shut off pump when water level is low)
Q	The water pump
R	Hand brake front
S	Left sweeping brush
T	Brush the left Saul Brush the left Saul
U	The main power supply 1
V	The main power supply 2

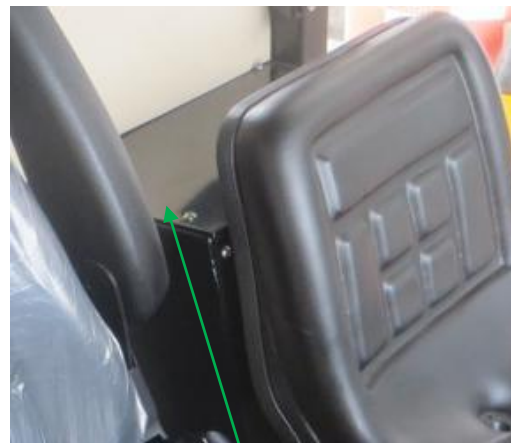

① Electric box cover plate



② Relay

Basic Information

	Fan 1 block
	Fan second
	Preheating relay
	Flash relay

Basic Information

1.10 The cab



Note !

Before starting the car, adjust the seat according to the driver's needs.

Front/back adjustment

Turn the front and rear adjusting lock lever to the left (Figure 3), then move the seat. After adjusting the seat, the lock lever must be locked in the desired position.

Weight

After the driver gets into the seat, adjust by rotating the control lever clockwise or counterclockwise (Figure 2). Adjust to the most comfortable flexibility according to the driver's weight.

The armrest

Handrails can be folded. (figure 1)

Backrest adjustment

Move the backrest locking lever upward (Figure 3) to adjust the backrest Angle. After adjusting the backrest, the locking lever must be locked in the desired position.

Steering column

Loosen the adjusting handle (Figure 4) to adjust the front and rear positions of the steering column.



Driver's seat



Weight adjustment



Before and after adjustment

Backrest adjustment

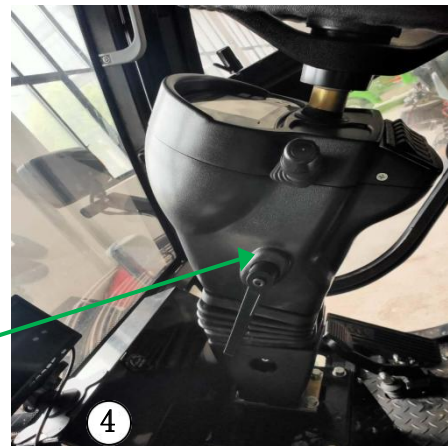

The regulating handle

1.11 Bridge heater/air conditioner

Bridge air heater

To turn on the bridge air heater, press the air heater switch downward on the front panel. (figure 1)



Air flow
switch

Cold and
warm air
switch

And use the air flow switch on the front instrument panel to adjust the air flow. (figure 1)

Air conditioner

To turn on the cab air conditioner, press the air conditioner switch upward on the front instrument panel. (figure 1)



outlet

And use the air flow switch on the front instrument panel to adjust the air flow. (figure 1)

Note: Air conditioning units and cab filters must be checked/cleaned once a year.

Cab ventilation

Air outlets are distributed in different positions in the cab (under the driver's seat, windshield and under the steering column). (FIG.)

1.12 Traction



Note!

The multi-function road sweeper CF-3310 is a vehicle with hydraulic transmission, which can only pull a few meters at most.

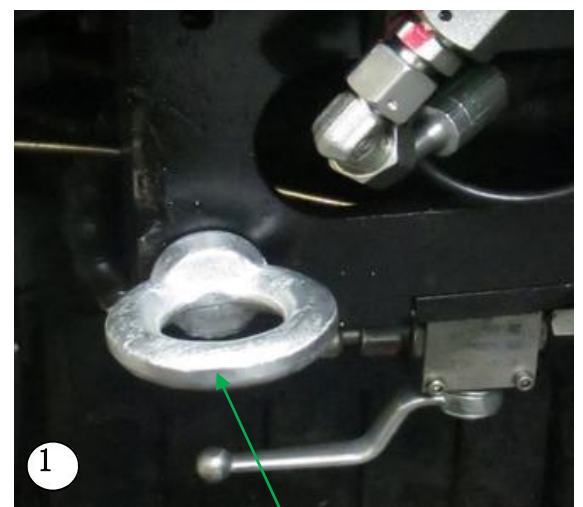

Draw hook

Traction

1. Turn off the engine.
2. During traction, connect the tow rope with the traction hook located at the front of the machine.
(figure 1)
3. Pull the vehicle a few meters without obstructing the traffic.

2.1 Installation/removal of control panel

Installation control panel

1. Unscrew knurling screws. (figure 1)
2. Install the control panel and tighten it with knurled screws. (figure 1)

Pre-startup check

After the accessory device is installed in the vehicle, the control functions of the panel need to be checked.

Remove the

Follow the installation operation in reverse order.

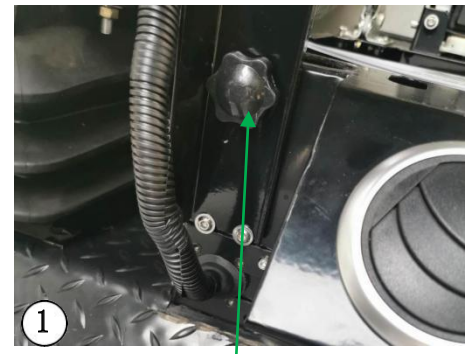

The knurled screw



2.2 Install/remove the brush

Install the sweeping brush

1. Put the brush fixed on the bracket directly in front of the vehicle. (figure 1)



2. Use the front suspension lift switch to reduce the sweep brush lift mechanism.

3. Lean the U-shaped groove on the vehicle brush lifting mechanism towards the circular connecting disk on the brush, so that the circular connecting disk is directly above the U-shaped groove.

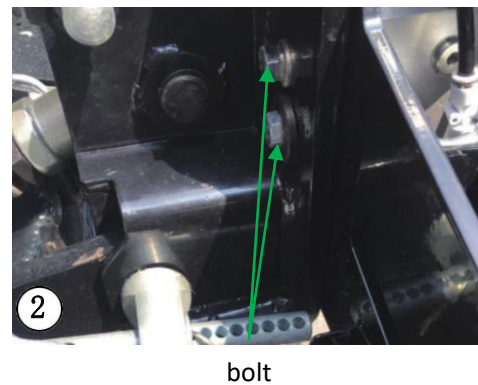

4. Raise the sweep brush lifting mechanism of the vehicle until the round connecting plate of the sweep brush is completely stuck in the U-shaped slot of the sweep brush lifting mechanism. Continue to lift the brush so that the brush holder is completely off the floor.

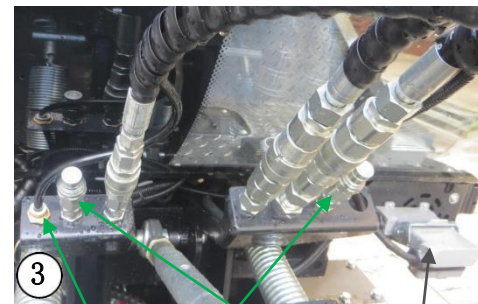

5. Use four own bolts to completely fix the brush on the brush lifting mechanism. (figure 2)

6. Raise the brush lifting mechanism of the vehicle to the maximum, and remove the bracket on the front brush.



Turn the stop ring to lock the hydraulic quick joint

7. Insert hydraulic quick connector, power quick connector and water supply quick connector.

(figure 3)

8. Rotate the stop ring 1/4 turn to ensure that the hydraulic quick joint is properly connected. (figure 4)

Remove the

Follow the installation operation in reverse order.

2.3 Installation/removal of recycling bins

Install recycling bins

- 1.1. Align the assembly car with the recycle bin installation platform on the rear frame. (figure 1)
2. Push the recycling bin assembly car forward until it stops.
3. Confirm that the two lockbolts of the recycle bin are pulled backward.
4. Adjust the height of the assembly car with the regulating wheel, and adjust the recycling bin to an appropriate position. (figure 2)
5. Hold the lever, pull out the safety pin and lift the assembly lever until the recycling bin is placed in the appropriate position on the rear frame. (figure 2)
6. Move the regulating wheel and remove the lock lever on both sides of the recycling bin. (figure 3)
7. Remove the recycling bin assembly truck. (figure 4)



Guide wheel

Draw Bar



Note!

The recycle bin must be higher than all parts of the base body during assembly.

8. Push the recycle bin lockout bolt, then lock the safety baffle, and finally install the locknut. (Figure 1 and Figure 2)



Note!

Do not dump the recycle bin if the safety stopper is not locked.

9. Properly tighten the lock nut of the safety baffle. (figure 2)

10. Connect hydraulic quick couplings. (figure 3)

11. Rotate the stop ring 1/4 turn to ensure that the hydraulic quick connector is properly inserted. (figure 4)

12. Connect the tail arrow lamp plug-in.

Remove the

Empty the recycling bin.

Follow the installation operation in reverse order.

2.4 Installation/removal of suction vent

Installation of suction vent

1. Use the front suspension lifting switch to raise the sweep brush lifting mechanism and the suction outlet fixed seat. (figure 1)
2. Place the suction tuyere under the fixed seat of the vehicle suction tuyere. (figure 2)
3. Connect the fixed seat of the suction tuyere with the vacuum hose and lock it with the original car clamp. (figure 3)
4. Use the brush lifting switch to lower the suction tuyere fixed seat. (figure 1)



① Front suspension lift switch

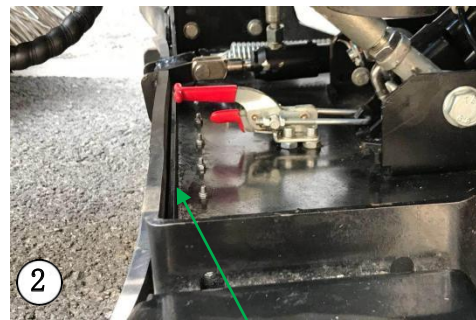

② absorb

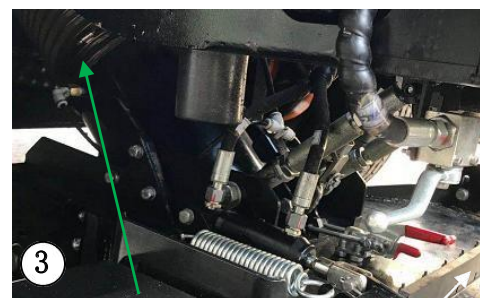

③ The vacuum hose Front baffle of suction outlet



④ Rapid clip lock

6.6. Assemble the cylinder and suction tuyere with flat pin shaft and split pin. (figure 2)If necessary, press the open and close button of the suction vent baffle to align the fork hole of the oil

7.Check the rubber height of suction tuyere. (See section 2.10)

Remove the

Lower the suction tuyere.

Follow the installation operation in reverse order.



①

Suction vent baffle switch on and off

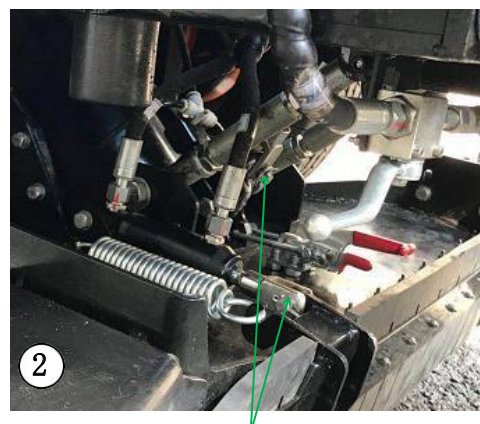

②

Pin shaft and cotter pin

2.5 Daily check before startup

1. Add water

Fill the tank with water before starting.
(figure 1)



Water mouth

2. Adjust the sweeping brush

Proper adjustment of the brush can prolong its service life.

Ensure that the brush is not overpressing the floor for cleaning. (See section 2.10)

3. Check around the vehicle:

- Condition of tyres and hubs, as tyres are often subjected to turbulence (sidewalk, street edge...)
- Tire pressure (refer to Section 1.3)
- The status of the accessory device
- The ground below the vehicle to check for leaks (diesel oil, hydraulic oil, lubricating oil, water, etc.)

If there is leakage, please find the leakage point and

contact the after-sale service department

- Check engine oil level (refer to Section 3.3)
- Check hydraulic oil level (refer to Section 3.4)
- Check the coolant level (refer to Section 3.5)
- Check the air filter blocking indicator (refer to Section 3.10) (Figure 2)
- Check lighting



An empty filter
Block indicator

2.6 Cleaning and inspection after each use

- . Clean the injection port filter
- Clean diaphragm pump filter
- Clean the high-pressure water pump filter
- Clean the radiator
- Clean the empty filter
- Clean air conditioning condenser (refer to Section 3.10)

2.7 Bunkering



Note !

The engine should be shut off before refueling.

Fuel outdoors or in a well-ventilated area.

Avoid sparks and fires. Diesel fuel is highly flammable.

Fuel

Only diesel oil meeting the following specifications can be used:

Cetane number	At least 45
viscosity	Minimum 2.0/ maximum 4.5 CST-40 °C (104° F)
The density of	0.835/0.855 kg/liter
sulfide	The maximum is not more than 0.2% of the mass
distillation	At 350 ° C (662° F), 85%

Note when refueling !

- Ensure no dust in the area when refueling
- Do not fill the tank too full
- Do not spill diesel oil
- No smoking

When the engine is running, burn through the multi-function instrument panel

Check oil level on oil gauge (refer to Section 1.5)



Wood is the cap

The diesel in the engine must not be used up to prevent air from entering Fuel system.

The oil cap is located on the left side behind the cab.
(figure 1)

2.8 Start, drive, stop

Please observe the following rules when driving

- Equipment users must be fully trained in the use and operation of multi-function road sweeper CF-3310.
- Do not drive on a slope greater than 20%. Drive carefully at all times
- Keep in mind that the multi-function road sweeper CF-3310 is relatively high and narrow. So you need to slow down when you turn.
- Do not keep the engine running in a closed area, otherwise it may cause suffocation.
- When the road is wet or loaded, the braking distance of the equipment will increase.
- Pay attention to sensitivity to turning.
- Do not open the door while driving.
- If the buzzer sounds while driving, please stop the vehicle in a safe place and refer to this operation Manual (refer to Section 1.5).

The following conditions must be met before the engine can be started.

- The driver must sit in the seat.
- Parking brakes must be tightened.
- All operation functions must be turned off (turbine fan, brush, water pump, light, air conditioner) (Figure 1)

Start the multi-function sweeper CF-3310



Job function

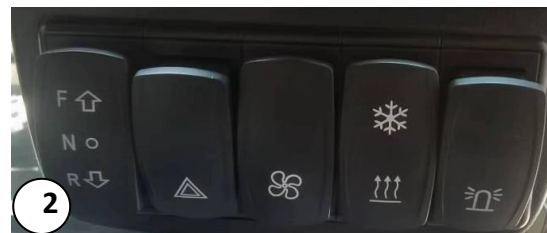

The gear is neutral



Ignition switch

- Place the right switch lever in the middle position (if the switch lever is in the forward or reverse position, the device will not start). (figure 2)
- Turn the ignition switch clockwise until the preheat indicator and other indicators are on (see section 1.5). After the preheat indicator is off, continue to turn the ignition switch to start the engine. (figure 3)
- Check the alarm light and make sure that no alarm light is on.
- Release the parking brake.



Drive

- Select the position of the right switch rod (Figure 1):

Forward - Vehicle forward

Middle position - Parking

Astern - A vehicle backing up

Wait for the vehicle to stop completely before reversing the drive direction.

- Press down the drive pedal.

There are three ways of braking

- Slowly release the drive pedal (engine brake). At this point the hydrostatic brake can act directly on the wheel motor.

- Press the brake pedal. The auxiliary braking system will operate on both front wheels.

- If the brake fails for some reason, you can use the parking brake for emergency braking, which ACTS directly on the front wheels.

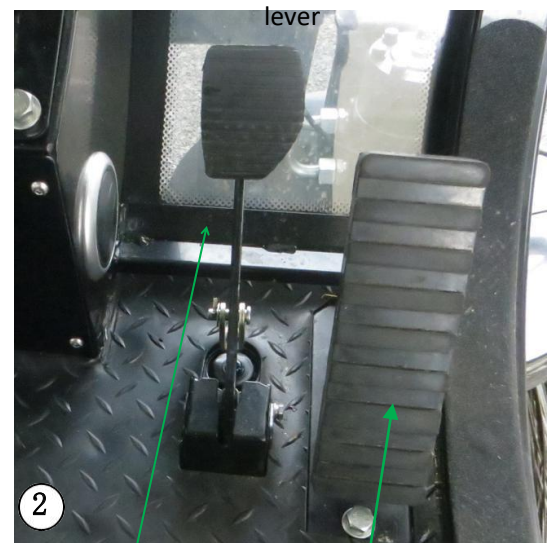

The brake pedal Drive the pedal

Warning!



In order to protect the hydraulic system, the machine must be kept at operating temperature.

Warning!



Operate the steering wheel carefully, the multi-function road sweeper CF-3310 is articulated and turns quickly.

Sweep along a sidewalk, roadside, or wall

Brush and obstacle touch lightly, do not cling to.

The brush will retract automatically when it hits an obstacle.

1. Raise the throttle lever to reach the maximum running speed of 3000rpm. (figure 1)
 2. Press the turbine fan switch downward and then release the brush. (figure 2)
 3. Use the front suspension lifting switch to lower the sweep brush. The function of this switch is to lower the brush and suction tuyere. (figure 2)
 4. Start the brush rotation with the brush speed control handle and slowly raise the brush speed control handle to increase the rotation speed of the brush. (figure 3)
 5. If you need to spray water for dust removal, please press the turbine fan switch upward (turbine fan + sprinkler). (figure 2)
 6. Use two knobs under the driver's seat to adjust the amount of spray. (figure 4)
 7. If larger garbage needs to be sucked away, please use the suction vent baffle opening and closing switch to open the suction vent baffle. (figure 2)
- Please close the baffle after sucking out the large garbage, so that the suction outlet can better absorb the garbage.



The throttle lever

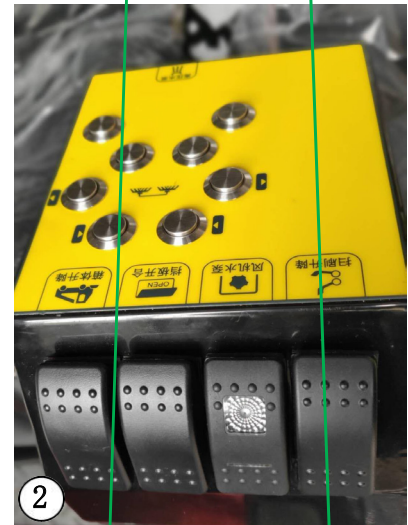

absorb
Baffle
opening
and
closing
Turbo fan
/ sprinkler

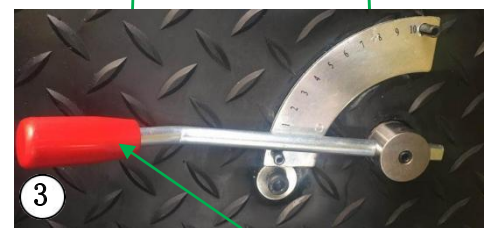

Brush the speed
regulating handle

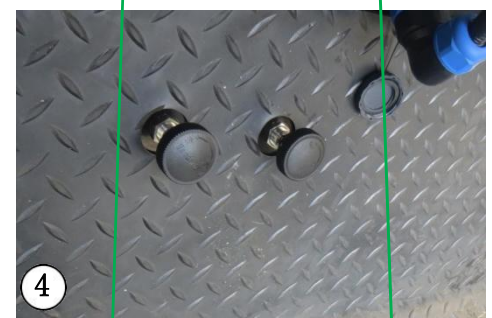

Brush water volume
adjustment knob
Suction vent water
flow adjusting knob

Shut down the multi-function road sweeper RG-8240

- Stop all operation functions (turbine fan, brush, water pump...) . (figure 1)
- Place the right switch bar in the middle.
- Lower throttle lever to reduce engine speed. (figure 2)
- Pull up the parking brake.
- Turn the key back to its original position (counterclockwise) and close the multi-function road sweeper CF-3310. (figure 3)



Note !

Use the parking brake after each stop. Even on flat ground, it should be used.

Operation with a front attachment device

- Before the multi-function road sweeper CF-3310 can be operated, the accessories installed must be lifted off the ground.
- Press the front suspension lift switch upward until the attachment is fully lifted.

(figure 1)

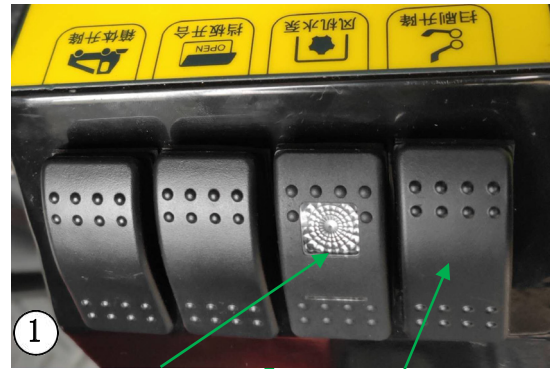

Turbine fan/pump

Front suspension lift switch



The throttle lever

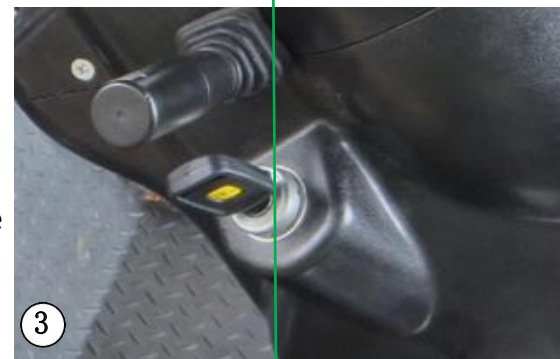

Ignition switch

2.9 Empty the recycling bin



Note!

The operation must be carried out in a suitable location. The sweeper should be stopped on the level road surface and the parking brake should be pulled up.



Note!

Confirm no one is behind the vehicle.
Do not move the vehicle when the recycling bin is raised.

1. Before emptying the bin, make sure there is enough space behind and above the vehicle to avoid bumping into anything as you raise the bin.

2. Raise and empty the recycle bin with the recycle bin tilting switch. (FIG. 1 + 2 + 3)

3. Empty the recycle bin after each use and when the container is full.

4. After emptying the recycling bin, press the recycling bin emptying switch to return the recycling bin to its normal position. Release the switch when the recycle bin is in low position.



Note!

Do not lower the recycle bin with safety support.

(Figure 4) Make sure the recycling bin is completely put down after emptying!



Recycle bin emptying switch



The recycling bin goes up



The recycling bin goes up



Remove the safety support

2.10 Wastewater discharge

1. Confirm that the recycling bin has fallen into place, find the appropriate place to put the sewage, and open the small door on the right side.
2. Remove the sewage pipe from the fixed position and aim the drain outlet at the sewer.
3. Turn on the red sewage drain switch and wait for the water in the recycling bin to drain. At this time, there will be a voice prompt that the valve is not closed.
4. After draining the sewage, turn off the switch.



2.10 Adjust the

Adjust the sweeping brush

Indicate the ideal area to clean. (figure 1)

1. Adjust the rake degree of sweeping brush with lifting rod. (figure 2)
2. Use no ballast spring to adjust the brush pressure: change the position of the R pin. (figure 3)
3. Use two bolts to adjust the rake Angle. (figure 3)



Note!

After the adjustment, slowly raise the front connecting device and make sure that the highest position of the lifting rod does not contact the front windshield glass.

Adjustable suction outlet

Check the gap between the rubber and the ground with the gasket provided in the vehicle.

1. Adjust the gap (C1) at both ends to reach 5mm.

Place the 5mm gasket under the rubber end of the suction tuyere, loosen the two screws of the front wheel to make the edge of the suction tuyere in contact with the gasket, and then tighten the two screws of the front wheel. (FIG. 1 + 2 + 3)

Do the same for the other side.

2. Adjust the rear clearance (C2) to reach 10mm.

Place the 10mm gasket under the back end of the rubber of the suction tuyere, loosen the screws of the rear wheel to make the rubber of the vacuum tuyere in contact with the gasket, and then tighten the screws of the rear wheel. (Figures 1 and 4)

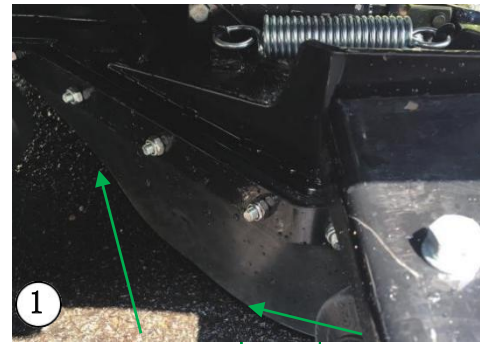

Clearance of C2 Clearance of C1



asket



The front wheel
bolt



The rear wheel
bolt Gasket

2.11 Water cannon

The water cannon is stored behind the recycle bin. Open the left rear door to take out the high-pressure water gun, then open the tailgate to take out the high-pressure hose. (figure 1)

Start the high pressure flushing function

1. Connect one end of the hose to the high-pressure water gun and the other end to the high-pressure water quick joint at the rear of the vehicle. (figure 2)

2. Raise the throttle lever to reach the maximum operating speed of 3000rpm.

3. Turn on the water gun switch on the control panel. (figure 3)

4. Adjust the water flow of the high-pressure water gun with the high-pressure water gun handle. (figure 2)



Water cannon The tailgate



High pressure water quick connection



Note !

All front hydraulic functions must be deactivated after turning on the water gun switch.



Note !

When the low water level indicator is on, please add water in time.

(figure 4)

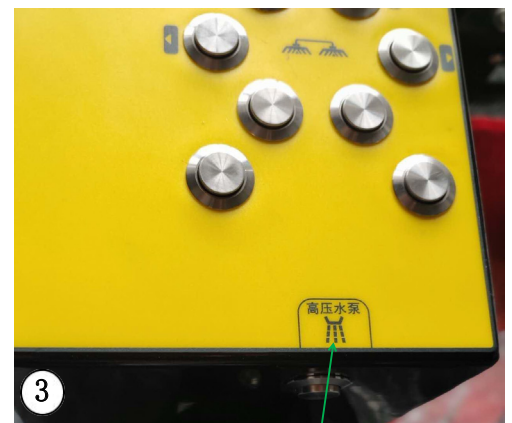

Water gun switch



Low water level indication

2.12 External suction hose

With an external suction hose, you can suck up any garbage that cannot be approached by vehicles. (eg: flower beds, grass, etc)

 **Note!**
External suction hose has a great negative pressure, do not put it towards people.

Do not suck chemicals, combustibles or explosive.

Start using the external suction hose

1. The external vacuum hose shall be stored in the rear of the vehicle. Open the right rear door, take out the external suction hose and the handheld straw and connect them. (figure 1 + 3)

2. Use the front suspension lifting switch to lower the suction tuyere and increase the negative pressure of the handheld straw.

3. Remove the external suction nozzle baffle, and then install the external suction hose to the original place where the suction baffle was placed. (figure 2)

4. Start the vehicle and raise the throttle lever to reach the maximum running speed.

5. Start the turbine fan with the switch on the operation panel.

Now you can use the external suction hose to remove the trash.



External suction baffle



Vacuum hose



Armed with a straw

2.13 Prevent the water circuit from freezing

To prevent damage caused by ice, water tanks, pumps and pipes need to be emptied when winter comes.

1. No water is allowed in the tank. The warning signal for low water level is on.(figure 2)
2. Through the injection port, add enough antifreeze to the water loop to prevent it from freezing. (figure3)
3. Turn on the sprinkling pump and high-pressure pump, so that the antifreeze flows through the whole hose and pump. (Figures 1 and 4)
4. Unscrew the pump strainer to drain the tank and hose. (figure 5)



Water gun switch



Low water level

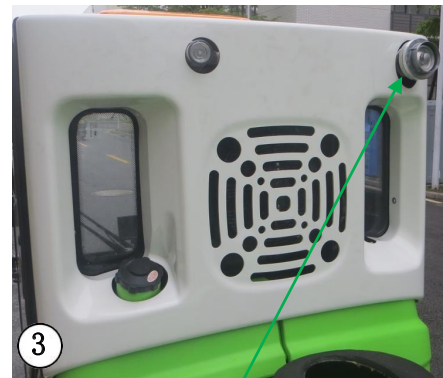

Water mouth

Press the top for the sprinkling pump



2.14 Transport multifunctional

road sweeper CF-3310

If the vehicle is to be transported, cross the straps and tie them to the four transport fasteners of the vehicle. (FIG. 1 + 2 + 3 + 4 + 5)



Note !

Be sure to recall the brush to avoid exceeding the width of the vehicle.

During transportation, the brush and suction outlets must be in an elevated position, while the brush rotation must be closed.



Note !

The emergency stop button must be pressed during transportation. (figure 2)



Transport CF-3310 road sweeper

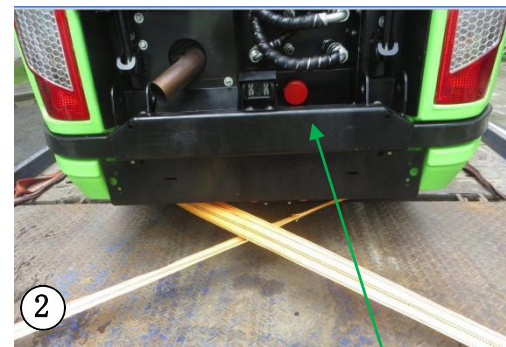

Rear cross fixation Scram button



Front cross fixation

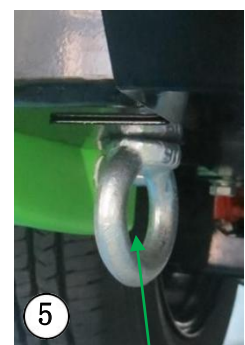

Forward transport fixed ring Rear transport fixed ring

3.1 Multi-function road sweeper CF-3310

maintenance and maintenance table.

◆ Clean ■ Lubrication ○ Check ● Replace

Operating unit	Maintenance schedule									
	Every day	50 hours	250 hours	500 hours	1000 hours	1500 hours	2000 hours	3000 hours	Every year	Refer to section
Empty filter	○			●	●	●	●	●		3.10
Engine oil (2)	○	●		●	●	●	●	●	●	3.3
Fuel filter				●	●	●	●	●		3.10
Generator, fan and pump belt			○	○	●	○	●	○		3.11
Cooling fluid	○							●		3.5
Cooling system Additives (1)				○	○	○	○	○	○	
Engine oil filter				●	●	●	●	●		3.10
Hose and clamp				○	○	○	○	○		
The radiator	◆									
Engine valve clearance					○		○	○		
The generator							○			
Engine shock absorber							○			
starter							○			
nozzle								○		
The water pump								○		
Brake fluid (3)		○	○	○	○	○	○	●		3.6
Hydraulic hose		○	○	○	○	○	○			

Hydraulic oil filter	○					●		●		3.10
Hydraulic fluid (4)	○					○		○		3.4
Plate spring shaft		■	■	■	■	■	■	■		3.9
Chassis hinged shaft		■	■	■	■	■	■	■		3.9
Steering cylinder ball head		■	■	■	■	■	■	■		3.9
Door hinge		■	■	■	■	■	■	■		3.9
Injector filter	◆				●		●	●		3.10
Pump strainer	◆				●		●	●		3.10
High pressure pump oil							●			
Compressor belt			○	○	○	○	○	○		3.11
Air conditioning condenser	◆									3.10
Air conditioning refrigerant									○	
lighting	○									
Brake fluid for drum brake (5)				◆○	◆○	◆○	◆○	◆○	◆	
Wheel bolts tightened		○	○	○	○	○	○	○		
Tire condition and pressure	○									1.3
The door to adjust				○		○		○		

- (1) The ethylene glycol level shall be checked every 500 hours and shall be checked before the arrival of winter.
- (2) Change the engine oil every 500 hours, at least once a year.
- (3) The brake fluid should be replaced every 3000 hours, at least once every two years.

- (4) Check the hydraulic oil quality every 1500 hours.
- (5) Clean the drum brake every 500 hours, at least once a year.

3.2 Clean

Daily cleaning and maintenance can extend the service life of the machine and its accessories.

After use, clean the sweeper with water.

Clean sweep the brush

1. Clean and brush with water.
2. Remove four water supply hoses from the brush sprinkler head.
3. Use a blow gun to sweep the sprinkler head along the arrow. (figure 1)

Clean suction vent

1. Clean the suction tuyere with water.
2. Remove the two suction tuyere nozzles and clean them with an air gun.

Clean the recycling bin

1. Clean the recycle bin filtration system
Remove the outer suction baffle on the side of the recycling box, and then clean the filter screen inside the recycling box with a high-pressure water gun. (figure 2)
2. Clean the inside of the recycling bin
Use the dump switch to lift the recycle bin and then use a water gun to clean the inside of the bin. (figure 3)



sprinkler

Water hose



Rinse the filter



Clean the inside of the recycling bin

Clean recycling Bin (continued)

3. Remove the lock release tool behind the recycle bin and release the two lock pieces.

(FIG. 1 + 2)

When the recycling bin is put down, the recycling filter will lock automatically.

4. Clean the recycle filter screen and the box behind with a high-pressure water gun. (figure 2)

5. Use the high-pressure water gun to clean the turbine fan. Please keep a certain distance from the fan impeller when cleaning. (figure 3)

Clean the external vacuum hose

1. After each use, please clean the external vacuum hose and the handheld straw, and put them back in the recycle bin in an appropriate position. (FIG. 4 + 5)

2. Check hoses regularly. Check for holes or cracks that might cause negative pressure to drop.



Lock release tool

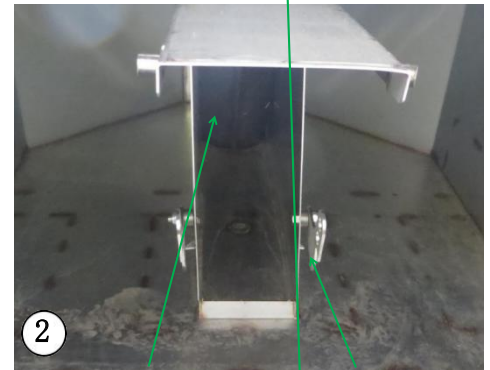

filter Lock plate



Clean the turbine fan through this opening



Hand-held Straw



External suction hose

3.3 Engine oil

Only commercial oils that meet the following grades may be used:

-APICh-4 multi-stage oil (preferred oil)

-ACEAE5

	Minimum	Maximum
SAE 0W20	-40°C (-40°F)	10°C (50°F)
SAE 0W30	-40°C (-40°F)	30°C (86°F)
SAE 0W40	-40°C (-40°F)	40°C (104°F)
SAE 5W30	-30°C (-22°F)	30°C (86°F)
SAE 5W40	-30°C (-22°F)	40°C (104°F)
SAE 10W30	-20°C (-4°F)	40°C (104°F)
SAE 15W40	-10°C (14°F)	50°C (122°F)

Viscosity at different temperatures



Note !

The viscosity of the oil must be suitable for the ambient temperature at which the machine operates. (figure 1)



Note !

Turn off the engine when checking the oil, changing the oil and changing the filter.

Check the oil

1. Park the multi-function road sweeper CF-3310 horizontally.
2. Wait at least 10 minutes after the engine has stopped to allow the engine oil to return to the tank.
3. Take out the oil gauge, dry it and put it back. (figure 1)
4. Then take out the oil scale and read out the oil number. The oil level must be between the highest and lowest level of the oil scale. (figure 2)
5. If there is a shortage of oil, please take off the fuel cap of the engine. Add the oil and check the oil level again in a few minutes. (figure 3)

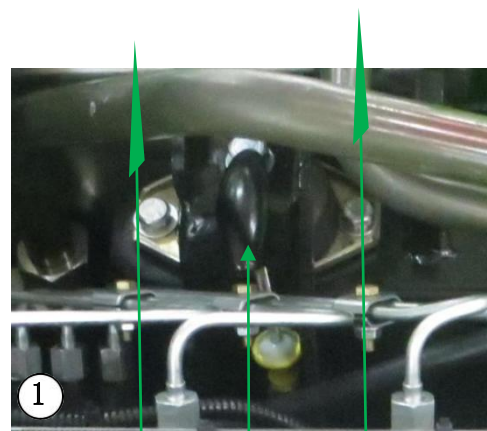

Oil scale



highest

lowest

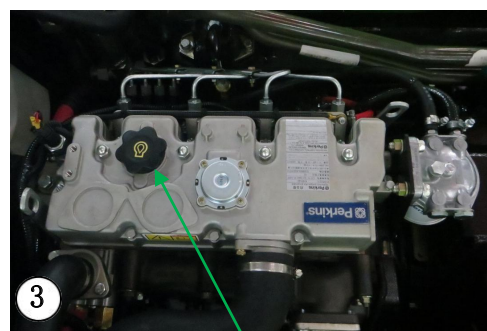

Engine oil refueling cap

Change the engine oil and filter



Note !

Drain crankcase with hot oil.



Note !

Hot oil and hot parts may cause personal injury. Do not allow hot oil or hot parts to come into contact with skin.

1. Park the multi-function road sweeper CF-3310 horizontally.
2. Open engine refueling cap. (figure 1)
3. Remove the engine drain plug and drain the oil into the pan. (figure 2)
4. Clean the drain plug after emptying, replace the new washer, and put it back.
5. Remove the filter with the appropriate tool.
6. Clean the sealing surface of the cylinder.
7. Apply clean oil to the new filter seal, then install the new filter and tighten it with the oil filter wrench.(figure 3)
- 8.8. Fill with new oil (about 8~10 liters, depending on the oil level above the oil scale) until the oil level reaches but not exceeds the highest oil scale, then close the oil cap. (figure 4)



Note !

Do not exceed the top of the oil gauge, or you may damage the engine.

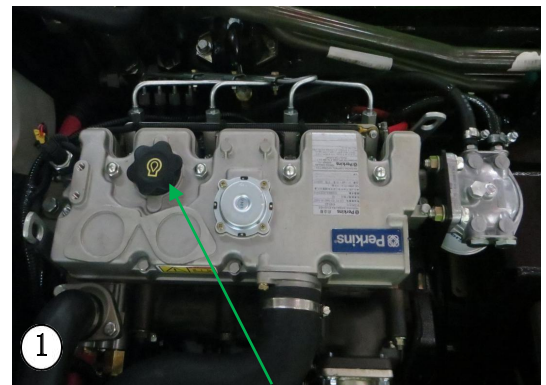

Engine oil refueling cap

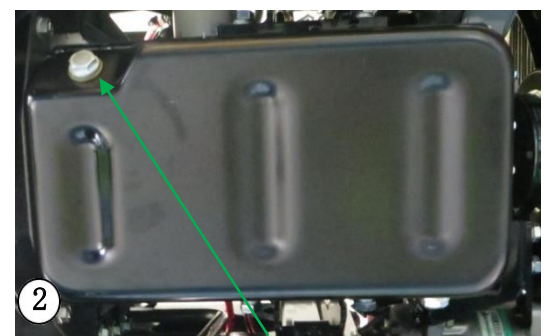

Engine drain plug



Oil filter



highest

lowest

3.4 The hydraulic oil

Check hydraulic oil level

1. Turn the vehicle to the left, stop the vehicle and open the radiator baffle.

(figure 1)

2. Take off the coolant tank and check the level gauge.

(FIG. 1 + 2)

3. The hydraulic oil level should be slightly above the 100 scale on the left. (figure 4)

4. If necessary, open the top cover of the hydraulic oil filter to fill the hydraulic oil tank. (figure 3)

Replace hydraulic oil

1. Park the multi-function road sweeper CF-3310 horizontally.

2. Remove the drain plug at the bottom of the hydraulic oil tank and drain the oil into the oil pan.

3. Clean the drain plug after emptying, replace the new washer, and put them back in.

4. If refueling is needed, please open the top cover of hydraulic oil filter in the right oil tank and connect the pump to the hydraulic oil filter. (figure 3)

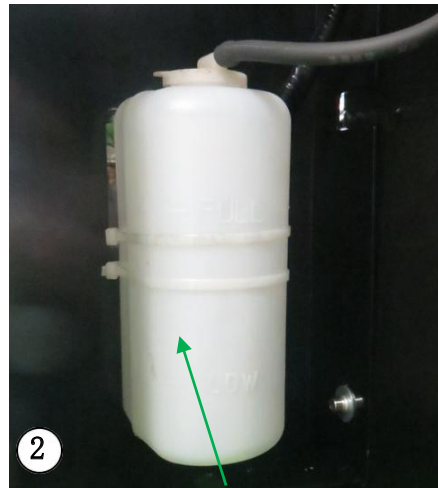
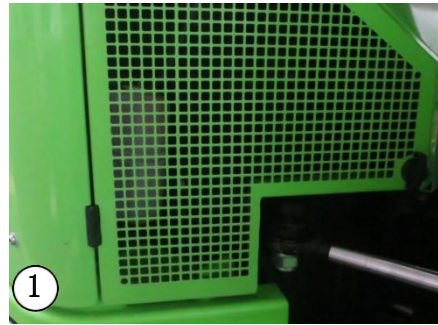

Cooling fluid

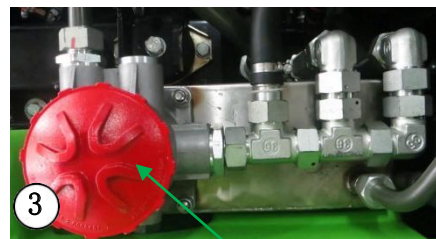

Hydraulic oil filter



The hydraulic oil level

Note !



Do not refuel otherwise as the hydraulic oil must be allowed to flow through the vehicle filter to prevent any contaminants from entering the hydraulic system.

3.5 Cooling fluid

Recommended coolant

The following two types of coolant can be used:

- First choice: Perkins Long-acting coolant (ELC)
- Acceptable: commercial heavy duty coolant according to "ASTMD4985" specification.



Note !

The engine must be shut down before coolant is added.



Note !

Do not remove the cooler cover when the engine is still hot to avoid serious burns caused by hot water overflow. Wait at least ten minutes after the engine is shut down before removing the cooler cover.

Check the coolant level

1. Coolant tank is located in front of engine body and rear radiator baffle. (figure 1)

2. Check whether the coolant level is in the middle of the coolant tank.

(figure 2)

3. If the liquid level needs to be adjusted, please turn the vehicle to the left, open the radiator baffle, unscrew the cover, and then replenish the coolant.

Fill with coolant

1. Turn the vehicle to the left, stop the vehicle and open the radiator baffle.

(figure 1)

2. Add coolant tank to half full. (figure 2)

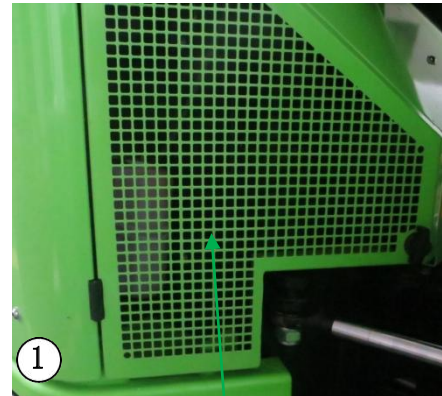

Radiator access door



Coolant kettle

3. Remove the radiator cap and fully fill the radiator with coolant: liquid must escape from the radiator. (figure 1)
4. Put back the radiator cap.
5. Turn on the warm air switch. (figure 2)
6. Start the engine, leave it idle, and then raise the engine to maximum RPM for 15 minutes. The liquid level will be adjusted automatically.
7. After the liquid cools down, check whether there is coolant flowing back from the radiator to the coolant kettle. (figure 3)
8. If necessary, fill the coolant tank to half full.



The radiator cap



Press down to warm air switch

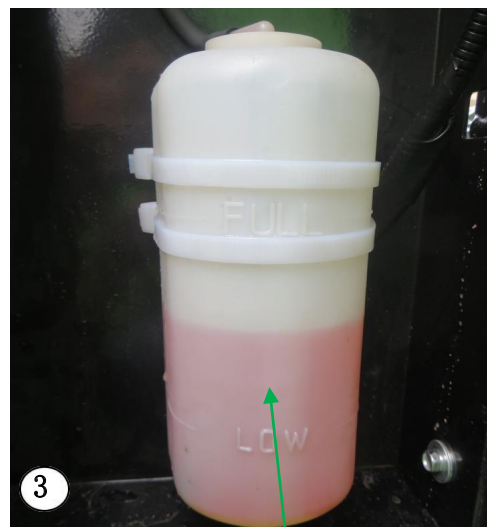

The coolant is half full

3.6 The brake fluid

Brake fluid used

Type of brake fluid used: DOT5.

Check the liquid level

1. Unscrew the four screws at the bottom of the steering column and remove the cover. (figure 1)
2. Check whether the brake fluid pot is 3/4 full. (figure 2)
3. If the liquid level needs to be adjusted, please unscrew the cap and add the brake fluid.

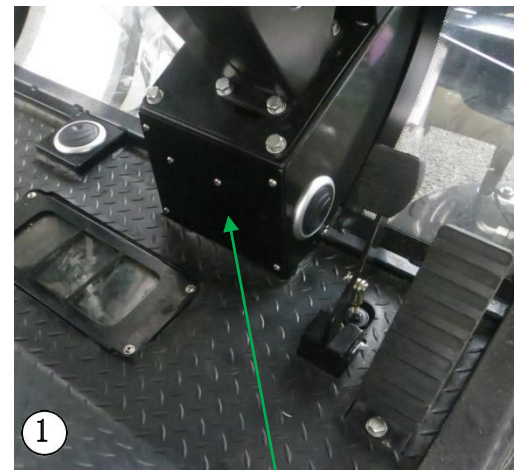

To remove the lid



The brake fluid pot

3.7 The rain wiper

In winter, please check whether the wiper liquid is antifreeze.

1. The wiper tank is located behind the cab and on the right side of the vehicle.
2. If wiper is needed, unscrew the lid. (figure 3)

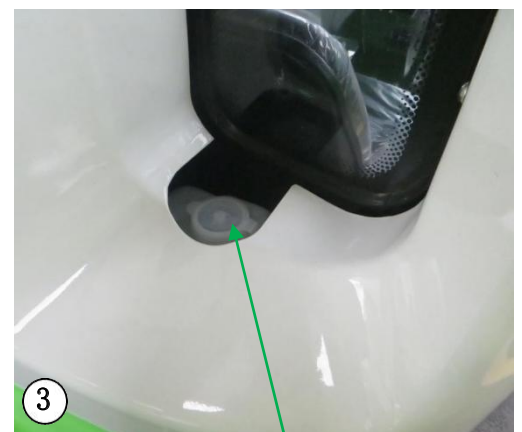

Wiper kettle

3.8 High pressure pump oil

High pressure pumps need to be replaced every 500 hours

High pressure pump oil.

- The recommended oil : High pressure pump XJS 11.14+F39

Check the oil level

Above the minimum oil level at all times. (figure 1)

Replace the high pressure pump oil

1. Remove the filler cap (small black cap above the pump), then remove the drain plug (located below the pump) and drain the oil into the pan. (figure 2 + 3)
2. Clean the drain screw plug after emptying and put it back in.
3. Add oil from the top of the pump and then close the black cap. (figure 2 + 3)

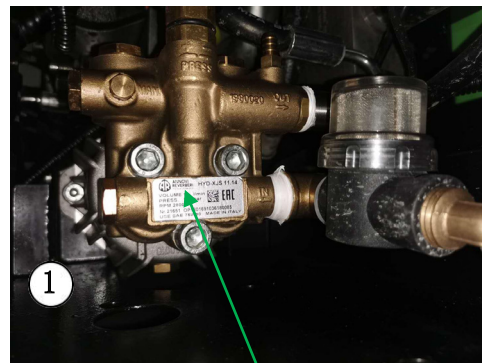

High pressure water pump



Red lid

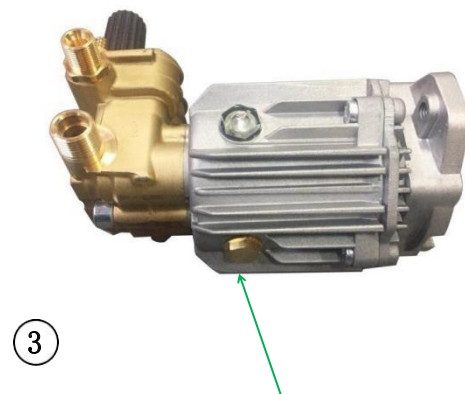

Oil discharge

3.9 Lubrication

Each component has a lubrication interval, please comply with the requirements.

Lubricant: High grade lithium-based grease.

Plate spring

Left and right front wheel spring shaft. (figure 1)

Plate spring shaft of left and right rear wheel. (figure 2)

Chassis hinged shaft

The chassis is hinged to two grease nozzles on the rotating shaft. (figure 3)

Steering power cylinder ball joint

Two grease nozzles on the steering power cylinder ball joint. (Figures 3 and 4)

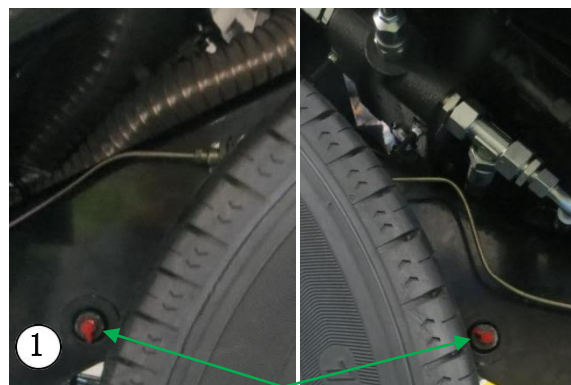

Left and right front wheel grease mouth

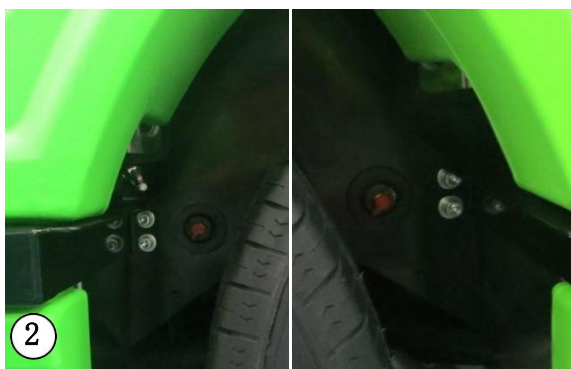

Left and right rear wheel grease mouth

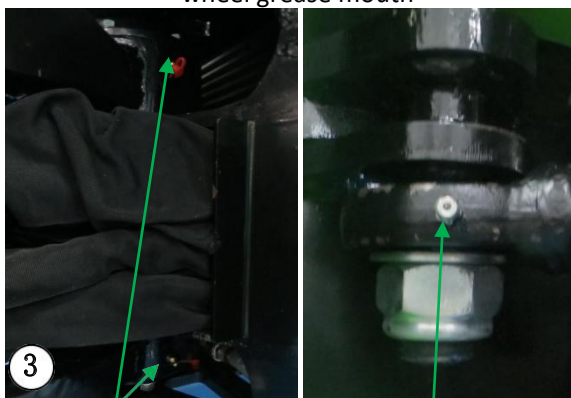

Grease nozzles for hinged shafts

Turn the rear grease nozzle of the cylinder

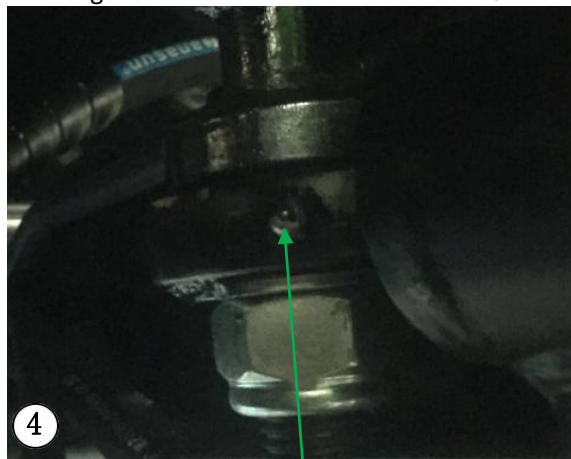

Turn to the front grease nozzle of the cylinder

Door hinge

Grease nozzles on left and right side door hinges. (FIG. 1 + 2)



The hinged grease mouth of the door

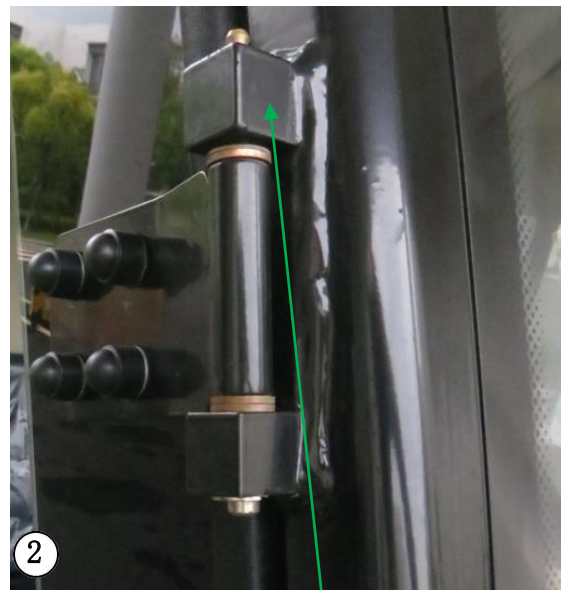

The hinged grease mouth of the door

3.10 The filter

Hydraulic oil filter

1. The hydraulic oil filter should be replaced every 1500 hours. (figure 1)

Injector filter

1. Remove the filter cover. (figure 2)
2. Clean the strainer and put it back. (figure 3)

Diaphragm pump filter

1. Remove the filter cover. (figure 4)
2. Clean the strainer and put it back.

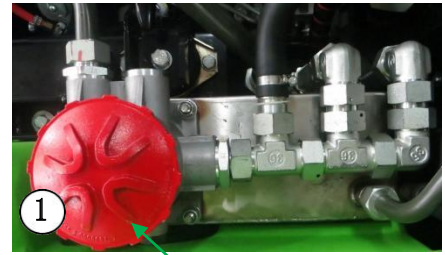

Hydraulic oil filter



Injector filter



Water injection net



Diaphragm pump filter

High pressure water pump filter

1. Remove the filter cover. (figure 1)
2. Clean the strainer and put it back.

Engine air filter



Note !

Do not remove the empty filter while the engine is running.

1. Check the air filter blocking indicator :(figure 2)

Turn the vehicle to the right, stop the vehicle and open the left radiator bulkhead.

Empty filter elements must be cleaned or replaced if:

- When the red part of the interior covers the visible position.

2. Clean the engine air filter

Turn the vehicle to the left, stop the vehicle and open the radiator bulkhead.

Remove the cover of the empty filter and check the condition of the empty filter.

(figure 3)

If the empty filter is dirty:

- Remove the main air cleaner component.
- Clean the empty filter cover and inside with a clean dry cloth.
- Clean the main air filter elements with a vacuum cleaner or low pressure compressed air. The auxiliary empty filter element cannot be repaired or cleaned. Replace the auxiliary air filter element every three times the main air filter element is cleaned. If the

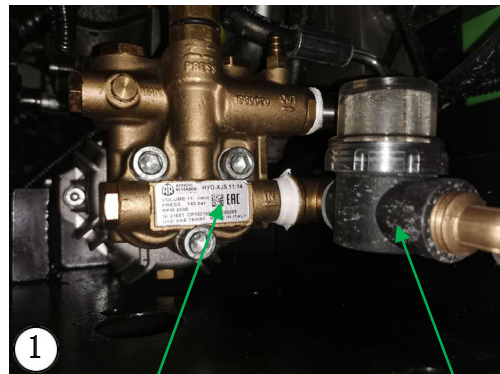

High pressure water pump

High pressure pump filter

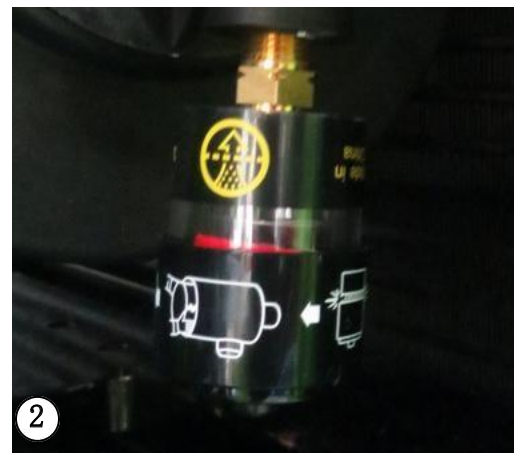

An empty filter block indicator

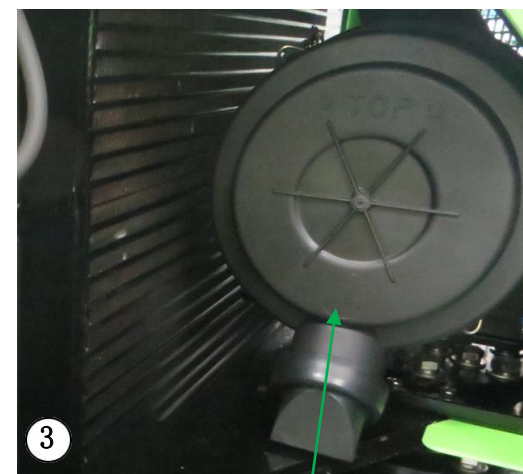

Air filter

main empty filter element is damaged, replace both components simultaneously.

- Put back the new or cleaned main empty filter element.
- Install the empty filter cover.
- Reset the empty filter blocking indicator: press the rubber button at the bottom. (figure 2)

Fuel filter

1. Stop the equipment.
2. Hold the fuel oil filter cup and remove the bolt. (FIG. 1 + 2)
3. Pour the fuel into a container and remove the fuel filter.
4. Check whether the seal is displaced.
5. Put the fuel filter and lid back into the filter cup. (figure 2)
6. Check that the gaskets and seals on the fixing screws are still in place.
7. Install the assembly on the fuel filter base with a retaining screw. (figure 2)
8. Start the system (Figure 2+3) :
 - Loosen hole screws on fuel filter.
 - Squeeze the manual start pump (the start pump is located below the tank).
 - Tighten the air hole screw when there is no longer air flow from the air hole screw in the fuel.

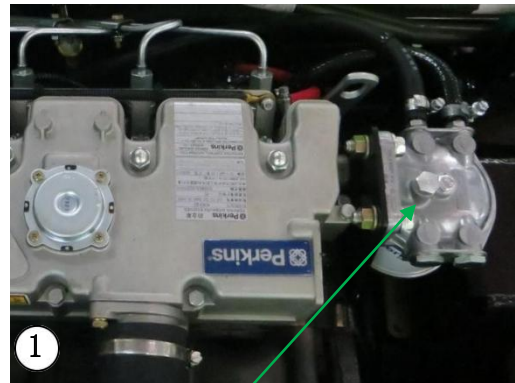

Fuel filter

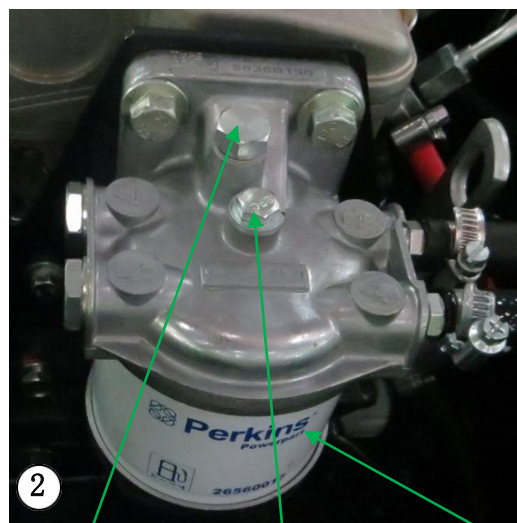

Stomatal bolt

bolt

Filter cup



Manual start pump

The radiator

1. Turn the vehicle to the left, stop the vehicle and open the radiator baffle.

(figure 1)

2. Use a high pressure cleaner or compressed air gun to clean the radiator: be careful to clean the entire height.

(figure 2)



Note !

When using the high pressure cleaner, please keep a safe distance and use a moderate pressure to avoid damaging the radiator.

Air conditioning condenser

In order to ensure the normal operation of the condenser, it is necessary to use a compressed air gun or high pressure cleaner to clean the condenser regularly at a moderate pressure. (figure 3)



Note !

When using a high pressure cleaner, keep a safe distance and use appropriate pressure to avoid damaging the condenser.

Cab filter

Replace the cab filter every 2000 hours. (figure 4)

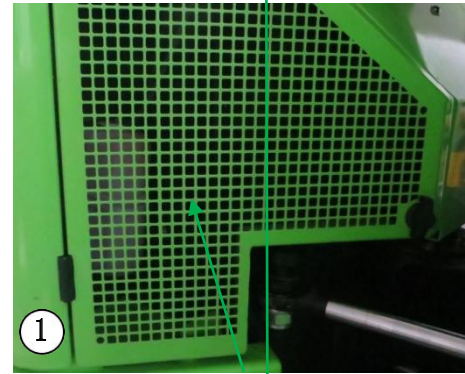

Radiator baffle

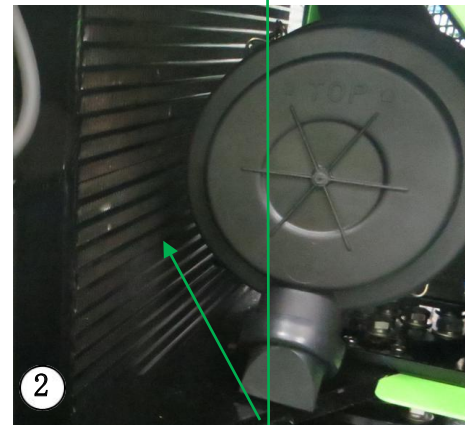

The radiator

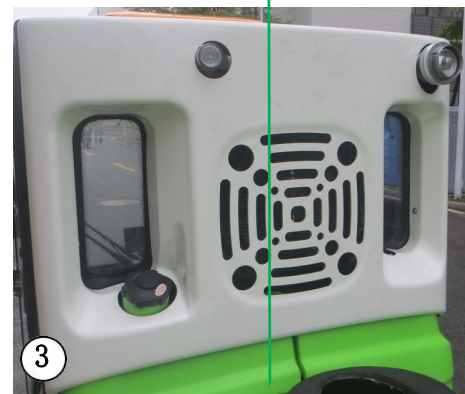

Air conditioning condenser

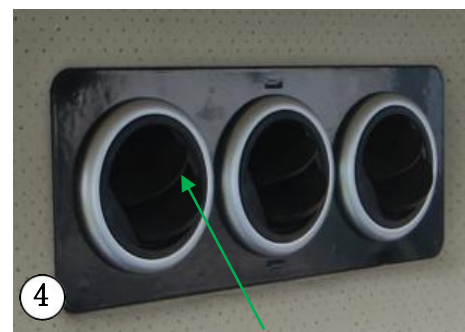

Filter inlet in cab

3.11 Check belt

Generator, fan and pump belts are checked for wear. (figure 1)

Compressor belt

Check belt for wear and proper tension. (figure 2)

3.12 Door adjustment

Check whether the screw of the lock is tightened. (figure 3)

2. Close the door and check whether the locking bolt is in the correct position inside the lock. (figure 4)

3. Check whether the door can be closed properly and whether the seal of the door is pressed tightly.

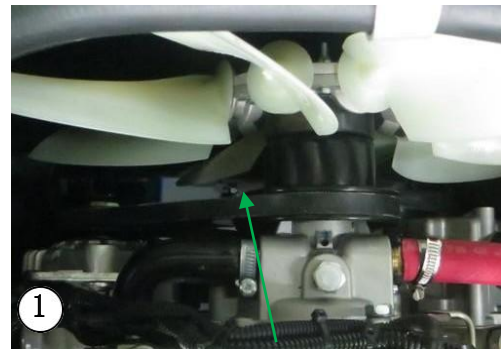

Alternator with wind vane



Compressor belt



The lock pin

Lock screw

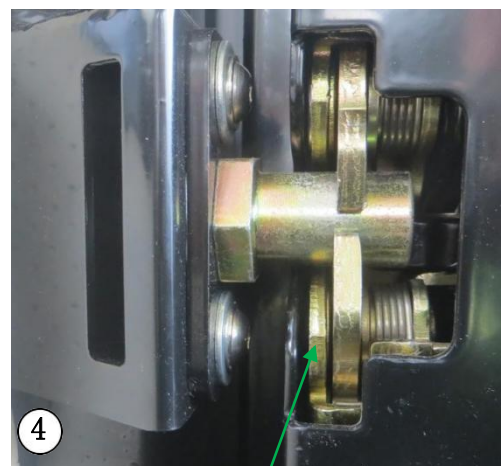

Door lock

3.13 Change the wheel



Note!

Please operate on a level stable ground.
The engine must be shut down and the parking brake pulled.

The job requires a jack that can hold more than two tons and a spare wheel with new tires.

1. Pad the wheel opposite the wheel to be raised.
2. Place the jack under the frame nearest the wheel to be replaced, as shown by the arrow. (FIG. 1 + 2)
3. After the jack is in place, loosen the wheel bolts.
4. Raise the jack until the wheel is a few centimeters above the ground. Pay attention to the stability of the vehicle as it rises.
5. Remove and replace the wheel. Screw on the bolts, but don't screw them tight.
6. Lower the jack and tighten the wheel bolts with a torque of 120N.m.

After 20 hours of use, tighten the wheel bolts again.

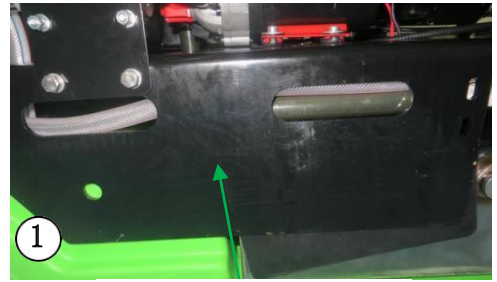

Position of rear jacks



Position of jack in front

3.14 Replace the sweeping brush



Note!

Use only the recommended brush.

Other brushes must be approved by the manufacturer.

1. Lift the brush. ①
2. Loosen the bolt to fix the brush. (figure 1)
3. Manually rotate the brush and remove it. (figure 1)
4. Install the screw on the new brush.



bolt

5. Install a new brush.

6. Retighten the screws.

In order to avoid excessive wear, be sure to adjust the brush. See Section 2.10.

3.15 The fault

Note !



The multi-function road sweeper CF-3310 is a vehicle with hydraulic transmission, so it can only pull a few meters at most without obstructing traffic.

When repairing the vehicle, please turn off the engine, take off the ignition key and pull the parking brake. Better to use the pad wood wheel pad, to prevent slippery slope. ^①

Call the after sales department to provide the frame number of your multi-purpose sweeper CF-3310. You can find the frame number on the vehicle's nameplate.

(figure 1)

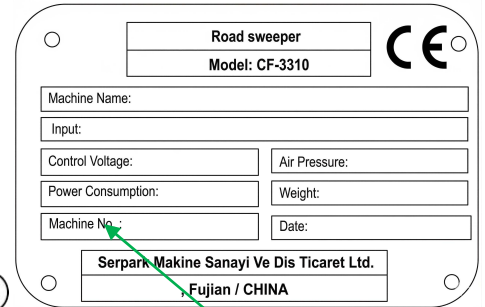

The frame number

3.16 Use a tube reel

1. Install the pipe coil at the head, which can be 10M in length. (figure 1)
2. When the flushing function is used, the end of the high-pressure water gun is butted with the head of the pipe coil. (FIG. 2 and 3)



Pipe winder

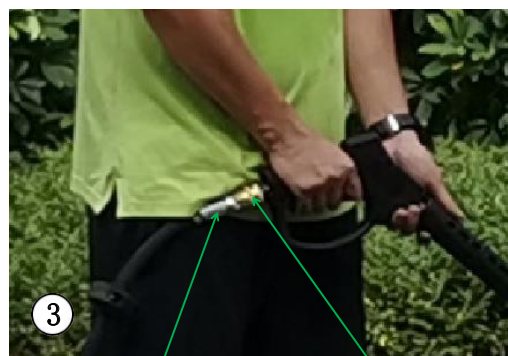

Coil pipe head

End of high pressure water gun

4.1 Product warranty

The material and production warranty of the multi-function road sweeper CF-3310 is 12 months from the date of purchase.

If any problem or defect occurs during the warranty period, Fujian Ronggong after-sales service Department will repair the machine free of charge according to the following terms and conditions.

Ensure that the scope of

1. The original receipt, including model number, frame number and purchase date, shall be provided to obtain the Warranty of Serpark CityFox Worker.
2. Routine inspection, adjustment, maintenance and technical parameter changes are not covered by this warranty.
3. All warranty claims should be submitted to the purchasing dealer.
4. Faults and defects which cannot be proved to be caused by material defects or production problems are not covered by this Warranty.
5. Consumers who buy the machine through legal channels can only apply for the warranty period.
6. If the maintenance is not conducted in accordance with the Operation Manual and Maintenance Manual and proved, Fujian Rongtong Factory reserves the right to refuse free maintenance within the warranty period.
7. Fujian Ronggong Reserves the right to improve and modify the relevant design of the product without improving the previous model delivered so far.

The warranty is not covered

- Wear and tear, accidents, operational errors, structural changes of the machine, and equipment damage caused by the use of non-Fujian Rongwen parts or accessory devices.
- Machine whose frame number is illegible.
- Damage caused by force majeure (lightning, flood, fire, war, etc.) or other causes beyond control.

4.2 Complaints

All applications relating to the machine, including normal use, maintenance and repair, spare parts and complaints, should be submitted to the distributor at the purchasing office.

We hope that you can use this machine safely and satisfactorily for a long time.

Best regards!

4.3 Processing

If your multifunctional sweeper CF-3310 reaches the end of its useful life after many years, it should be handled in an environmentally responsible manner according to the relevant handling regulations.

1. Used hydraulic oil shall be sent to a regular waste treatment plant or site for treatment.
2. Remove plastic and rubber parts and dispose of them in accordance with applicable environmental regulations.
3. After unloading the above parts, the machine shall be handed over to the local regular waste dealer.

5.1 Spare parts - Multi-function road sweeper CF-3310



Spare parts replacement in 500 hours



Replacement of spare parts in 1000 hours



Spare parts 1500 hours to replace



Spare parts 2000 hours to replace



Spare parts replacement for 3000 hours

5.2 Wearing parts - Multi-function road

Sweeper CF-3310



Tires and hubs 195/75 R16



Hydraulic oil filter element

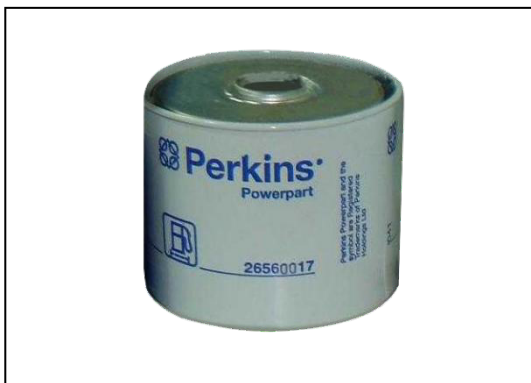

Fuel filter



Engine oil filter



Compressor belt



Fan belt

Wearing parts -- Multi-function road sweeper CF-3310 (continued)



Drain plug washer

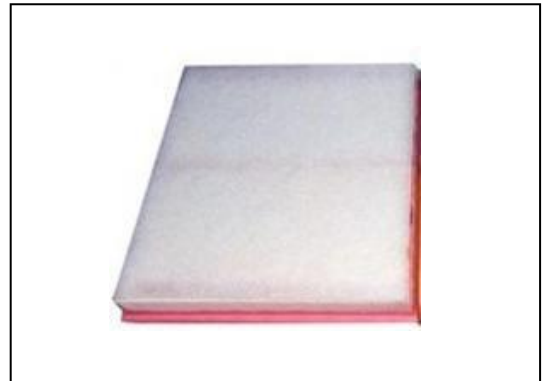

Bridge filter

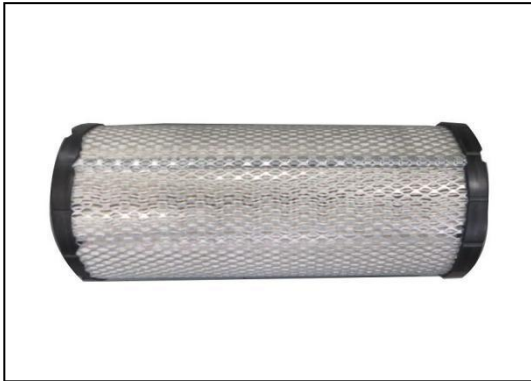

Main air filter element



Auxiliary air filter element



The filter water networks

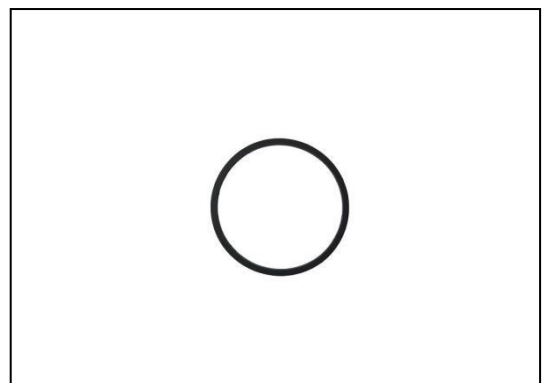

Water filter O ring

Wearing parts -- Multi-function road sweeper CF-3310 (continued)



Universal suction tyre wheel



Suction tyre directional wheel



Suction tyre rubber baffle

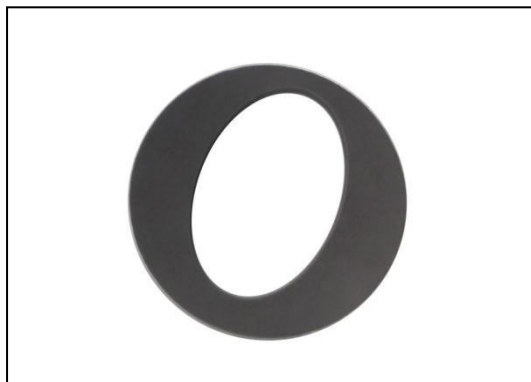

Straw gasket



The nozzle



Nozzle nipple

Wearing parts -- Multi-function road sweeper CF-3310 (continued)



Sweep the brush



Suction tuyere main straw



Water cannon



High pressure flushing pipe of pipe coil

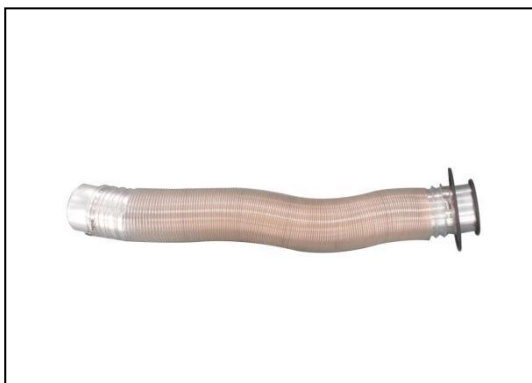

Vacuum hose

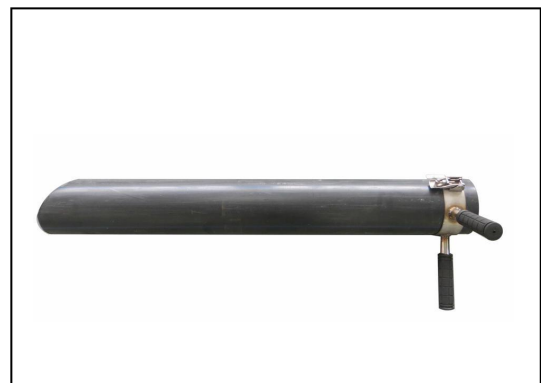

Armed with a straw

Optional accessories - multi-function road sweeper CF-3310

The RG-8240 is also available with optional accessories, snow brush and snow plough, enabling easy switching between sweeping, rolling and pushing snow on a single vehicle. The installation and replacement of sweeping brush, snow brush and snow plough are simple and convenient, and the operation is safe and reliable; In the operation, the sweeping brush, snow roller and snow plough can be automatically adjusted with the transverse slope of the road to fit the ground. It is especially suitable for areas with snow in winter, it can be used for regular sweeping as well as snow removal, making it truly versatile with multiple functions in one machine.

The width of the rolling brush is 1100mm, the angle can be freely adjusted at $\pm 34^\circ$ range, and the snow can be swept to the side of the road by rotating the nylon rolling brush. The snow plow blade has a width of 1350–1650mm and a height of 70mm. Both the left and right blades can be freely adjusted within a $\pm 20^\circ$ range. The road sweeper moves forward to push the accumulated snow to the side of the road.

6.1. Installation/disassembly of snow brush

Installation

1. connect the snow rolling component to the front suspension.
2. Tighten the interlocking bolts.
3. Insert the quick-connect oil pipe fittings as shown in the diagram, and connect according to the coupling markings.

Disassembly

Disconnect the quick-connect oil pipe fitting, loosen the connection bolts, and then separate the snow brush attachment from the front suspension.



Quick-connect coupling for the oil pipe

Snow Brush



6.2 Installation/disassembly of snow plough

Installation

1. Connect the snow plough with the front suspension.
2. Tighten the connecting screws.
3. Insert the quick-connect oil pipe fittings as shown in the diagram, and connect according to the coupling markings.
4. Connect the power aviation connector.



Snow plough

Disassembly

Disconnect the quick-connect oil pipe fitting, loosen the connection bolts, unplug the power aviation connector, and then separate the snow plow attachment from the front suspension.

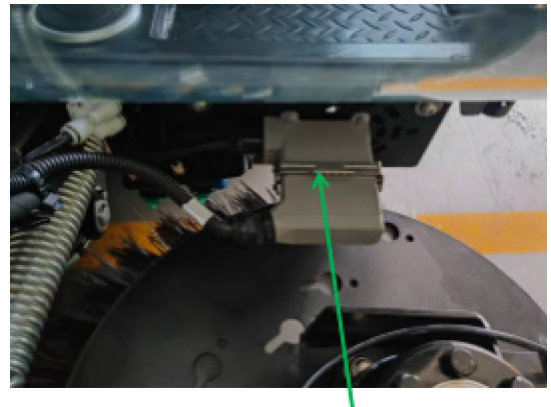

Power aviation connector

6.3 RSP-300 Spreader Installation and use

I. Installation of RSP-300 Spreader

1. Install install the L-shaped bracket onto the spreader.
2. Lift the spreader.
3. Connect the L-shaped bracket to the vehicle body according to the diagram.



L-bracket

spreader

II. Usage of RSP-300 Spreader

1. Purpose

This machine is vehicle-mounted and suitable for spreading anti-slip sand and snow melting agent on ice and snow roads. It is an essential and important equipment for municipal roads and expressways.

2. Structure and characteristics

The machine consists of major components such as the engine, transmission, body, adjustment handle and discharge outlet (see Figure 1). Mount the installation bracket on the rear bumper of the vehicle (see Figure 2).

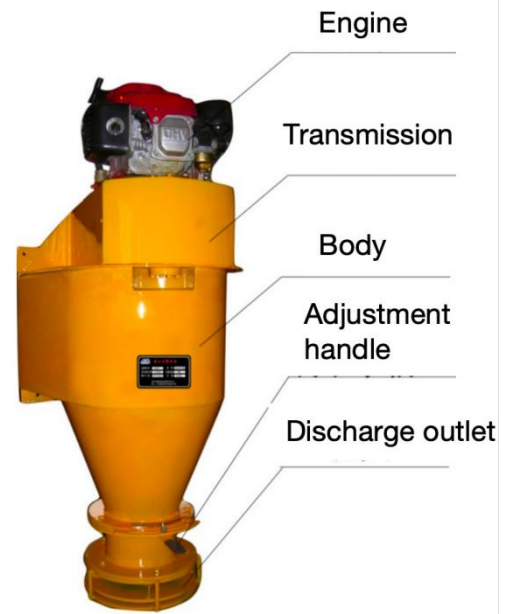

Figure 1

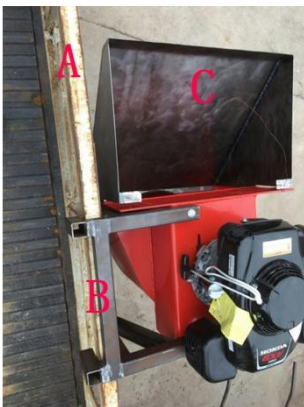

Illustration:

A	rear panel
B	mounting rack
C	hopper

3. Technical parameters

Item	Parameter	Item	Parameter
Vehicle speed	20-30km/h	the quantity of spread	0.25-0.8kg/m ²
Engine parameter	5.5 HP (Honda) gasoline engine, 1.9 liter gasoline tank, about 2-3 hours of operation		
Volume	1350×600×450mm	full weight	125Kg

Note:

1. Before use, the engine operating manual must be read. Lubricating oil must be added before the first start-up of the engine (oil

capacity is 0.65 liters).

2. When starting a cold engine, the throttle handle must be set to the maximum and locked, and the choke lever should be set to the closed position (if the engine is warm or the temperature is high, do not use the choke). Gently pull the starter rope handle until you feel resistance, then give it a strong, quick pull. After the engine has warmed up, adjust the throttle handle from high speed to low speed, and then make further adjustments as needed.
3. The amount of spreading can be adjusted by regulating the engine speed and the adjustment handle located underneath the spreader to achieve the best spreading effect (see Figure 3).
4. The maximum particle size of sand and gravel must not exceed $\phi 25\text{mm}$. No metal objects, ropes, or woven bags should be mixed in.
5. During spreading, no one should stand within 15 meters around the discharge chute to avoid injury.

6. **Wearing parts**

Name	Model
A triangular belt	A800
A triangular belt	A750

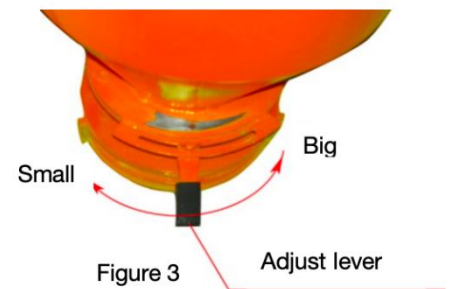

6.4 Installation and Use of the RSP-1000 Vehicle-Mounted Spreader

I. Installation of the Vehicle-Mounted Spreader

1. Pull out the rotating lock handle shown in Figure 1, and sequentially rotate the four support legs to position the leg supports facing the ground. Then push the lock handle back in.



the spreader to

the desired height.

3. Reverse the 3310 road sweeper to the appropriate position, ensuring that the frame is directly above the rear vehicle frame's straight beam.

4. Sequentially rotate the four handles shown in Figure 1 to lower the frame onto the rear vehicle frame's straight beam, ensuring the four support legs are lifted off the ground.

5. Fully insert the left and right locking rods, as shown in Figure 3, into the locking holes at the bottom of the frame to secure the frame to the vehicle chassis.



Rotary Handle



Rotary Locking Handle



Locking Rod



Locking Hole

6. Install the safety guards shown in Figure 5 and Figure 6, along with the corresponding nuts, and tighten the nuts.

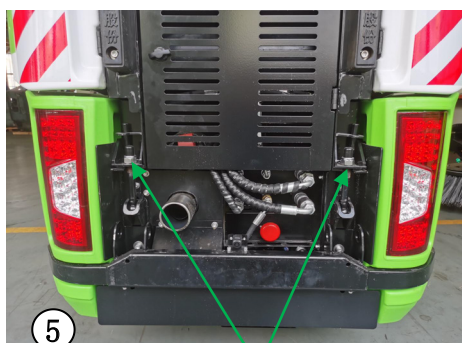

Recycling Bin Lock

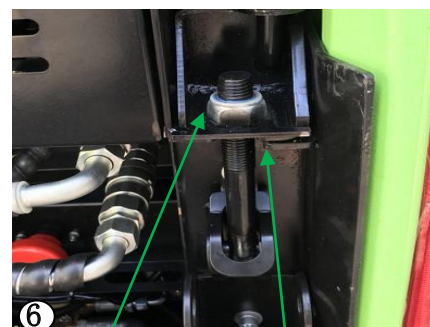

Nut

Safety Guard

7. Insert the hydraulic quick-connect fitting as shown in Figure 7, and push the retaining ring to lock the quick-connect fitting in place. The quick-connect fitting with heat-shrink tubing on the vehicle should be connected to the quick-connect fitting with heat-shrink tubing on the spreader.

8. Open the right rear vehicle door, disconnect the arrow light plug as shown in Figure 9, and connect it to the corresponding plug on the spreader.

9. Once installation is complete, remove the pin shown in Figure 2, and store the four support legs separately to prevent them from being struck during operation.

10. Flip the ladder upwards and secure it with the rubber strip shown in Figure 10.

11. Once the spreader is installed, it is ready for normal use.

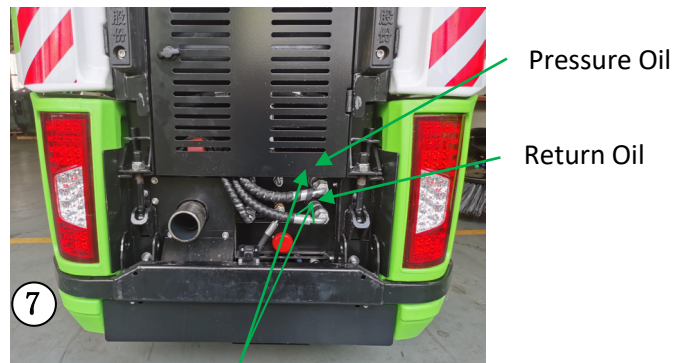

Pressure Oil

Return Oil

7

Hydraulic Quick-Connect Fitting

Ladder Securing Rubber Strip

Arrow Light Plug



10



9



8

Rotary Retaining Ring, Lock the Hydraulic Quick-Connect Fitting

II. Operation of the RSP-1000 Vehicle-Mounted Spreader

1. Start the road sweeper as usual.
2. Turn on the alarm indicator light shown in Figure 1



1

Alarm Indicator Light

to power the spreader.

3. Press the turbine fan switch downward, as shown in Figure 2, to activate the fan and provide pressure hydraulic oil to the spreader.
4. Press the spreading button and the feeding button as shown in Figure 3 to initiate spreading. Note: Press the spreading button first, then the feeding button, to prevent salt from accumulating on the spreading disc after feeding.
5. Adjust the spreading distance and material feed rate using the pressure adjustment, spreading speed adjustment, and feeding speed adjustment controls shown in Figure 4.



When installing the spreader, the turbine fan switch should only be pressed downward to activate the fan. Pressing it upward may cause the diaphragm pump for water spraying to run dry and be damaged.



Turbine Fan + Spraying Switch
(Pressing upwards activates both the fan and spraying function, Pressing down activates the fan only)

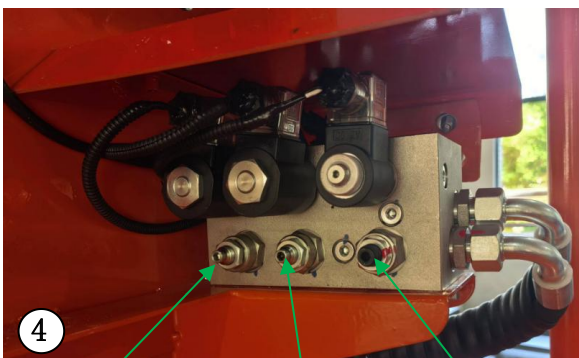

Feeding Speed Adjustment Spreading Speed Adjustment Pressure Adjustment



Spreading Button Feeding Button

6.5 Installation and Use of the Snow Thrower Attachment

I. Installation of the Snow Thrower Attachment

1. Follow the instructions in Section 2.2 of this manual for the installation and removal of the sweeper brushes to disassemble the sweeper brushes.
2. Use the front suspension lift switch to lower or raise the front mounting mechanism.
3. Align the U-shaped slot on the vehicle's front lifting mechanism with the circular connecting plate on the snow thrower, ensuring the circular connecting plate is directly above the U-shaped slot.
4. Raise the vehicle's front mechanism until the circular connecting plate is fully secured into the U-shaped slot. Continue raising the front mechanism until the snow thrower is completely lifted off the ground.
5. Use the bolts removed from the sweeper brush assembly to securely fasten the snow thrower to the front mounting mechanism (see Figure 1).
6. Insert the hydraulic quick-connect fitting, connecting the pressure oil quick-change connector with the heat-shrink tubing (see Figure 3).
7. Rotate the retaining ring 1/4 turn to ensure the hydraulic quick-connect fitting is properly connected (see Figure 3).
8. Once connected, the snow thrower is ready for use.

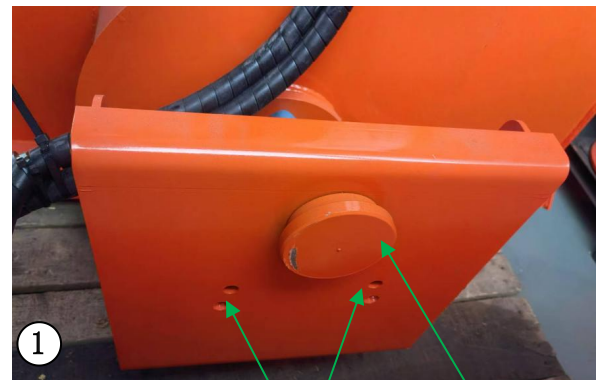

Snow Thrower Mounting Hole
Circular Connecting Plate

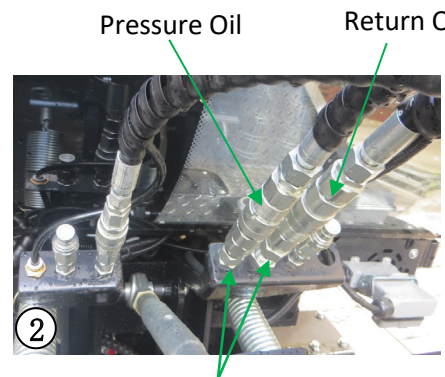

Hydraulic Quick-Connect Fitting



Rotary Retaining Ring, lock the Hydraulic Quick-Connect Fitting

II. Use of the Snow Thrower Attachment

1. Start the road sweeper as usual.
2. Adjust the height of the snow thrower above the ground using the sweeper's brush lift switch (see Figure 1).
3. Adjust the snow throwing distance using the sweeper's speed control handle (see Figure 2).
4. Loosen the fastening bolts to adjust the angle of the guide hood, which controls the snow throw angle (see Figure 3).
5. Loosen the snow thrower guide hood fixing screws to adjust the direction of the snow throw (see Figure 4).



Brush Lift Switch



When opening and closing the sweeper speed control handle, please operate slowly to prevent rapid movement that could cause motor impact.

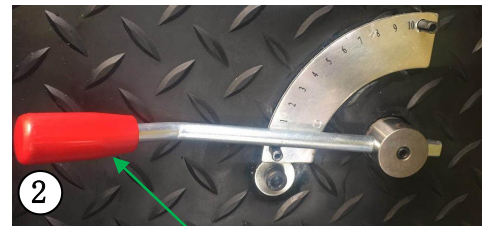

Brush Speed Control Handle



Snow Thrower Guide Hood Fixing Screws

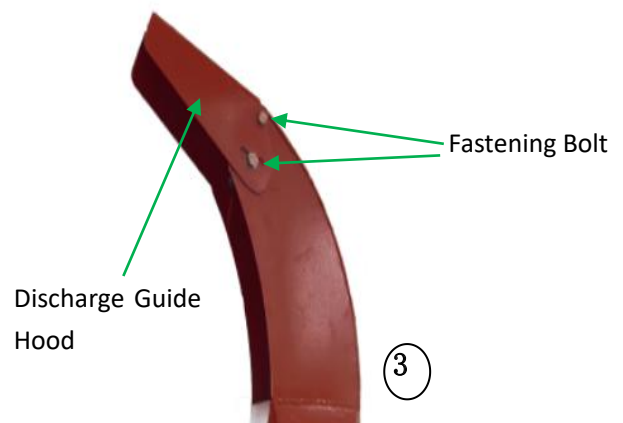

Discharge Guide Hood

6.6 High pressure washing device

The high pressure washing device can be easily switched with the sweeping device, and the sweeping and high pressure washing function can be easily realized.



Water tank bracket:

Length	1950 mm
Width	1120 mm
Height	1215 mm
Weight	195 kg
Aluminum alloy water tank capacity	1000 L
AR high pressure water pump	30 L/min
Continuous flushing time	30 min
High flush pressure	135 bar
Length of coil hose	10 m



When using the high-pressure flushing function, the engine speed is controlled between 1500-2200 RPM. If the engine speed exceeds 2300 RPM for a long time, the high-pressure water pump will be damaged.

High pressure washing parts:

Length	800 mm
Width	1600 mm
Height	690 mm
Weight	68 kg
Number of water nozzles	6 pcs
Flush width	1600 mm
Flush swing angles	L 20°/R 23°

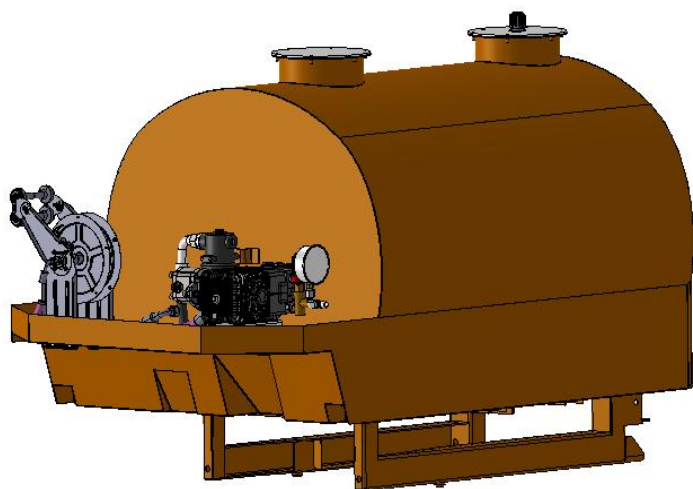

I Water tank bracket

installation/disassembly

1. Disassemble the recycling box according to 2.&3.

Installation/Removal of the Recycling Box.

2. Hoist the tank bracket onto the rear frame and adjust it until it fits.

3. Install the left and right support limit rods removed from the recycling box on the new water tank bracket. (Figure 1)

4. Push the anti-loose bolts on the left and right sides of the recycling box, then use the safety stop to fasten the support limit rod, and finally install the locking nut and tighten it.(Figure 1)



Safety Baffle

Check Bolt

Locking Nut

Bracket
limit rod



Attention!

When the safety baffle is not locked, do not use it, because the tank bracket may loose and fall when the vehicle is walking.

5. Connect the hydraulic quick change connector and the water quick change connector as shown in Figure 2.
6. Rotate the stop ring 1/4 turn to prevent the hydraulic quick connector from falling off.

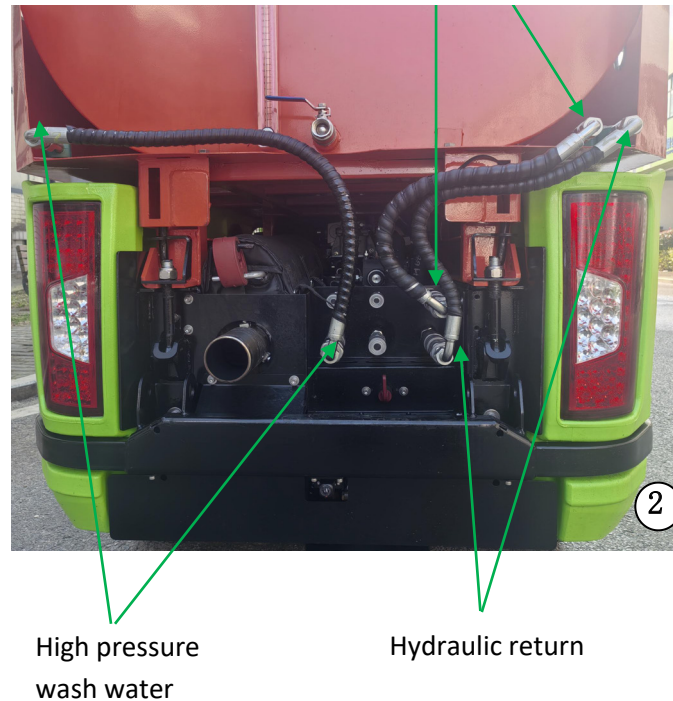

Attention!

The quick change joint should not be connected incorrectly, otherwise it will cause damage to the hydraulic system.

Disassembly

To empty the water tank, follow the reverse order of the water tank bracket installation.

II High pressure washing parts installation/disassembly

1. Remove the original brush according to "2.2 Brush Installation/Removal".
2. Place the high-pressure flush front part, which is fixed to the bracket, directly in front of the vehicle as shown in Figure 3.
3. Use the front suspension lift switch to lower the brush lifting device.

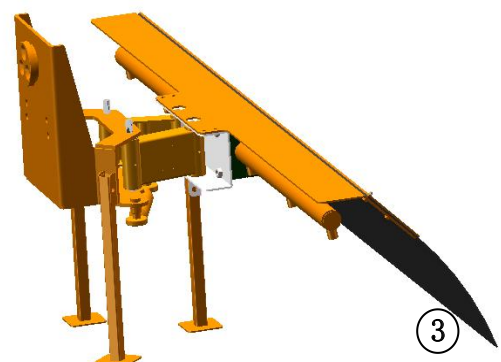

4. The U-shaped groove on the lifting mechanism of the vehicle brush is leaned against the circular connecting disc on the high-pressure washing part so that the circular connecting disc is directly above the U-shaped groove.

5. Raise the brush lifting device of the vehicle until the circular connection disc of the high pressure washing part is completely stuck in the U-shaped slot of the brush lifting device. Continue to raise the high pressure washout to completely lift it off the ground as shown in Figure 4.



hex bolt

Circular connecting disc

6. Secure the brush completely to the brush lifting mechanism with two hex head bolts. (Figure 4)

7. Raise the vehicle's brush lifting mechanism to its maximum and remove the 3 legs from the high-pressure washing parts.

8. Insert hydraulic quick coupling and water supply coupling.(Figure 5)

9. Rotate the stop ring 1/4 turn to prevent the hydraulic quick joint from falling off.(Figure 4)

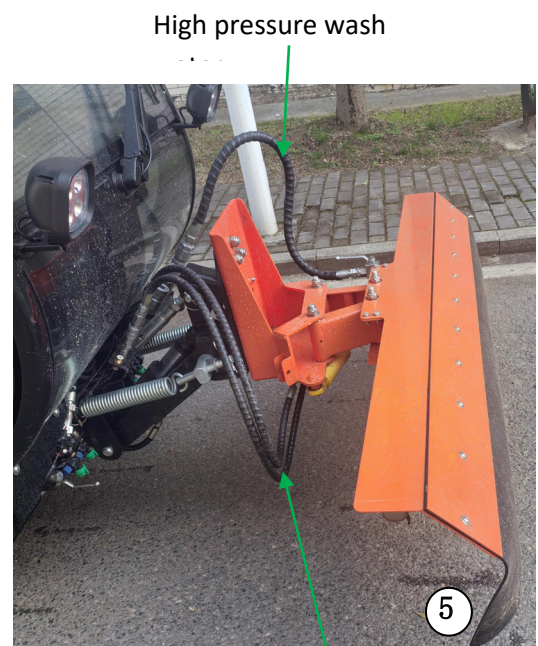

High pressure wash

hydraulic pipe

Disassembly

Perform the installation in reverse order.



Attention!

Quick change joint can not be wrong, hydraulic oil and water quick change mixed will cause damage to the hydraulic system.

III Operating Instructions

1. please test all quick change connector connections to ensure that the connection is correct.
2. The vehicle starts normally, and the engine speed is controlled between 1500r/min and 2200 r/min.
3. Press the fan pump button to open the high-pressure water pump. (Figure 6)
4. Press the left swing and right swing buttons to make the spray rod swing left and right. (Figure 6)
5. The high pressure washing parts and high pressure water gun can be switched to wash by the front ball valve and the coil side ball valve.(Figures 7 and 8)



Fan pump button
(press up for fan and spray water, press down only for fan)

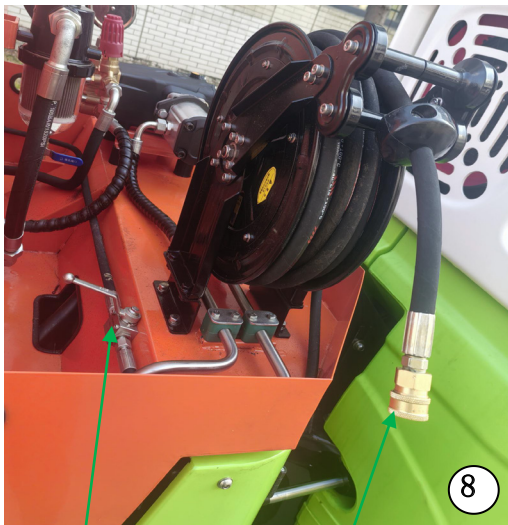

Ball valve

high-pressure water gun joint

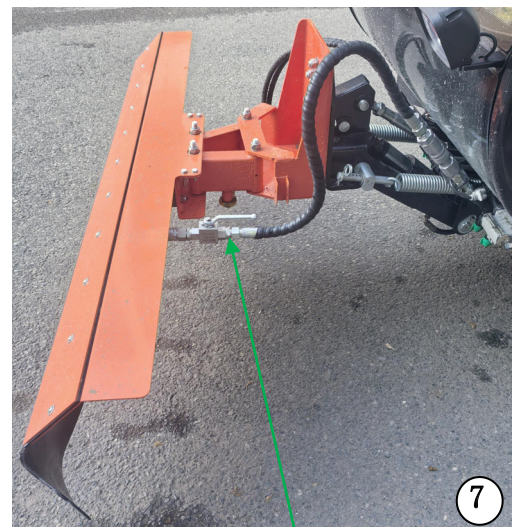

Ball valve

6. Equipped with a water filter, and at the bottom of the water filter is connected with a sewage discharge ball valve. Filtered sand and gravel pollutants can be discharged through the sewage discharge valve. There is no need to clean the filter. (Figure 9)

7. Equipped with the water pressure control handle and water pressure gauge and high pressure pump set pressure 135bar.(Figure 10)
8. The rear of the vehicle is equipped with water hydrant fittings, water level gauges and water drain ball valves.



Sewage discharge ball

Water filter

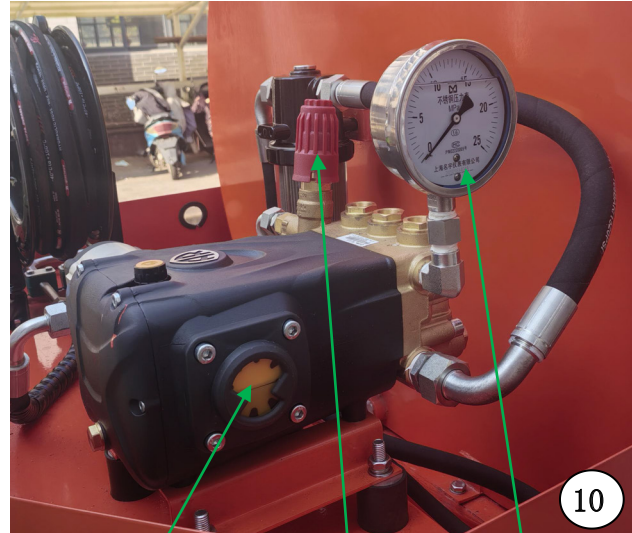

High pressure pump lubricating oil level

Control handle

Water pressure gauge



Attention!

When using the high-pressure flushing function, the engine speed is controlled between 1500-2200 RPM. If the engine speed exceeds 2300 RPM for a long time, the high-pressure water pump will be damaged.



Inlet hydrant connector

water gauge

Water tank drain ball valve

Professional road sweeper manufacturing enterprise

Making cleaning simple

Note: This manual is an operational guide and not a product warranty. Our company reserves the right to interpret any printing errors, discrepancies with the latest information, and product improvements, as well as the right to make changes at any time. These changes will be incorporated into the revised edition of the manual without prior notice.

+90 533 773 65 79

SERPARK MAKİNE SANAYİ VE DIŐ TİCARET LTD.

Mansurođlu Mah. 288/4 Sok. A Blok No:9/1 K:2 D:27 Bayraklı 35535 İzmir - Türkiye

T: +90 232 969 72 55

E-mail: info@serpark.com

www.serpark.com