



Component Maintenance Manuel

Multifunctional Road Sweeper

CF-3310 & CF-3310F



Content

Lamps, Rear-view Mirrors.....	4
Water Filter, Hose Reel.....	6
Wheels, Motors.....	7
Air Filter, Oil Filter.....	8
Suction Outlet.....	9
Sweeping Brush.....	11
Engine.....	12
Oil Pump.....	14
Radiator.....	16
Valve, Steering Cylinder.....	18
Front and Rear Quick Connectors.....	19
High Pressure Water Pump.....	22
Cab.....	23
Glass.....	31
Condenser, Evaporator.....	33
Relays, Fuses.....	34
Back Door.....	35





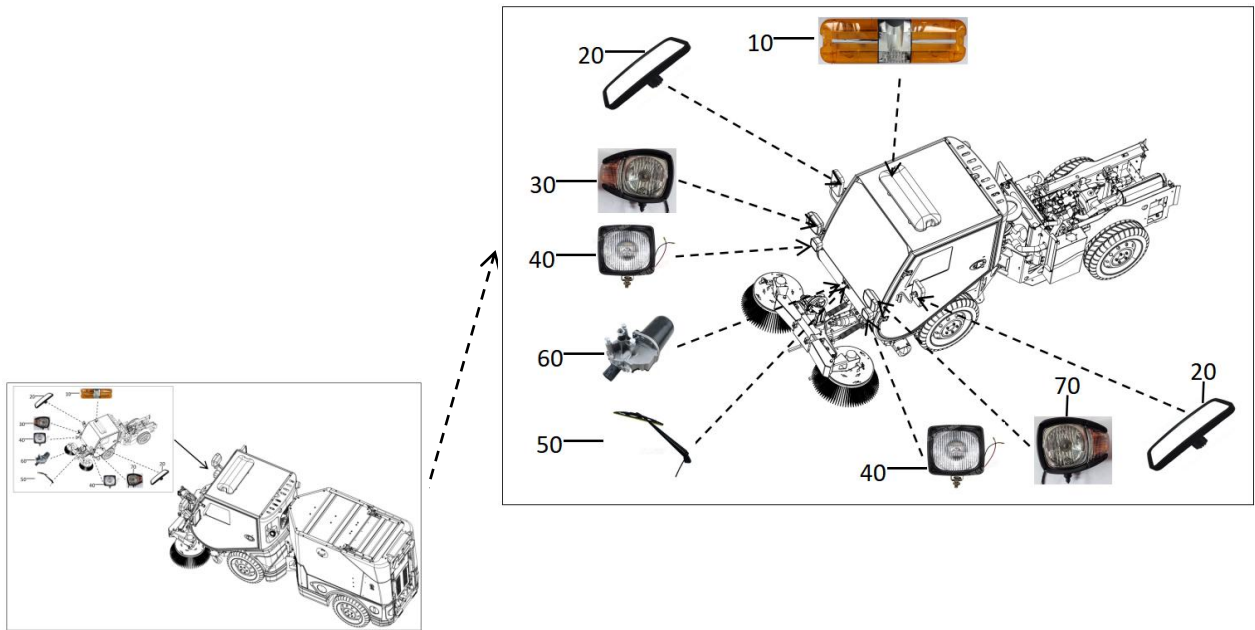

Content

Hinge Joint.....	36
Mesh Little Door.....	38
Blower.....	40
Side Suction Tube.....	42
Fuel Tank, Water Tank.....	43
Sewage Discharge Structure.....	45
Recycling Bin Filter.....	48
Sewage Filter.....	50
Back Cover of Recycling Bin.....	51
Left Supporting Arm.....	54
Right Supporting Arm.....	57
Main Frame of Recycling Bin.....	60
Rear-left Door.....	64
Rear-right Door.....	67
Sweeping Brush.....	70
Support Frame of Sweeping Brush.....	72



Content

Landing Gear of Sweeping Brush.....	75
Front Frame.....	79
Recycling Bin Covering.....	82
Radiator Covering.....	85
Right Hydraulic Tank.....	87
Left Hydraulic Tank.....	90
Rear Frame.....	93
Left Tank Fastening.....	95
Right Tank Fastening.....	98
Rear Fixing Parts.....	100
Nozzle of Suction Outlet.....	103

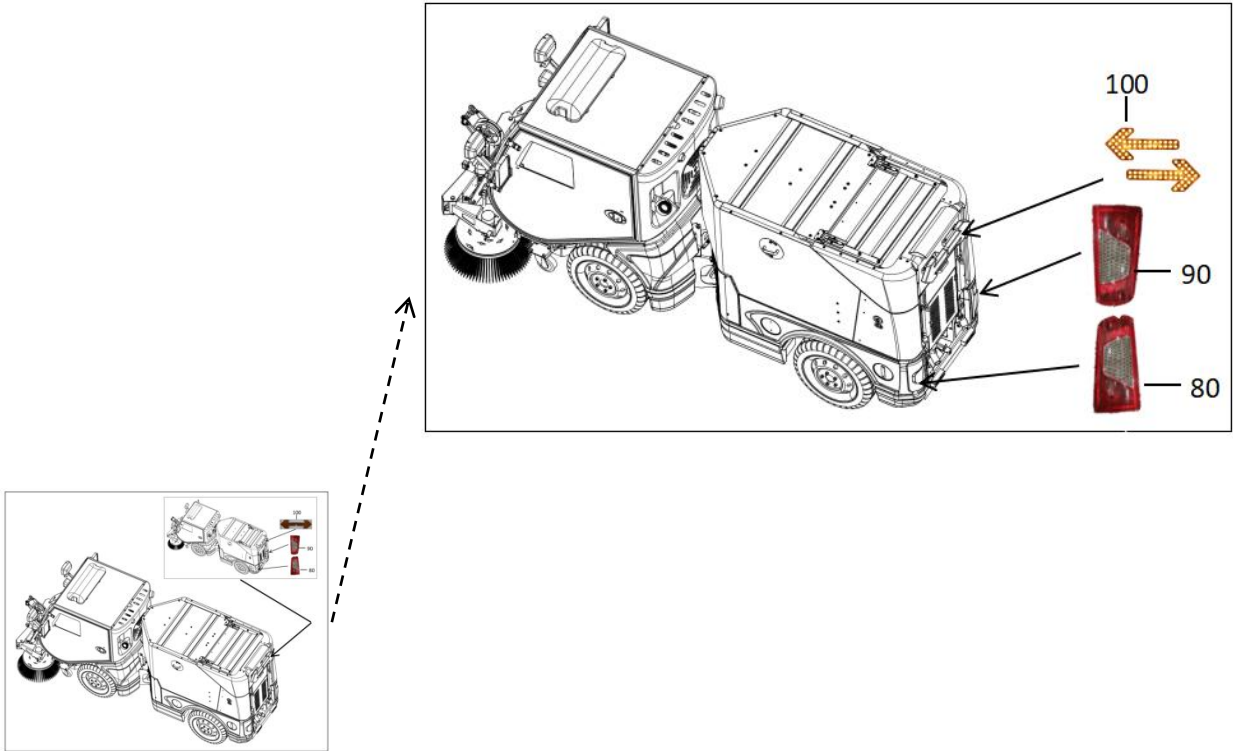

No.	Picture	Description	Material Code	Quantity
10		Alarm light	z023	1
20		Left and right rear-view mirrors	A001-55	2
30		Right front running light	A001-72	1
40		Working light	A001-61	2
50		Wiper support rod	06.A001-45	1
60		Wiper motor	06.A001-44	1
70		Left front running light	A001-72	1





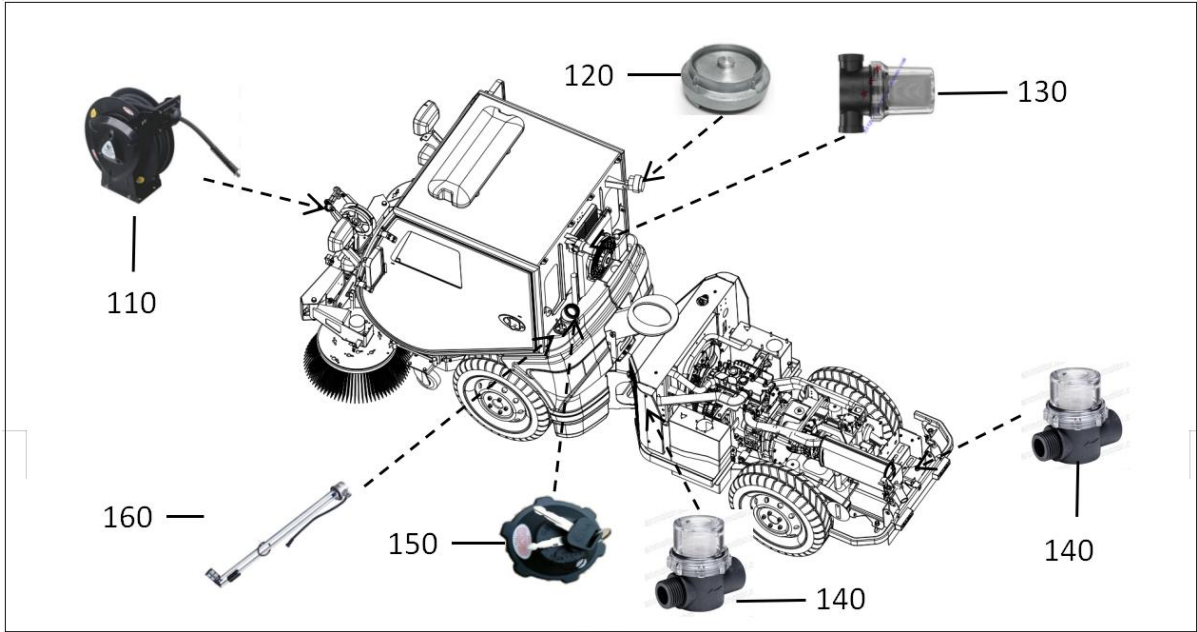

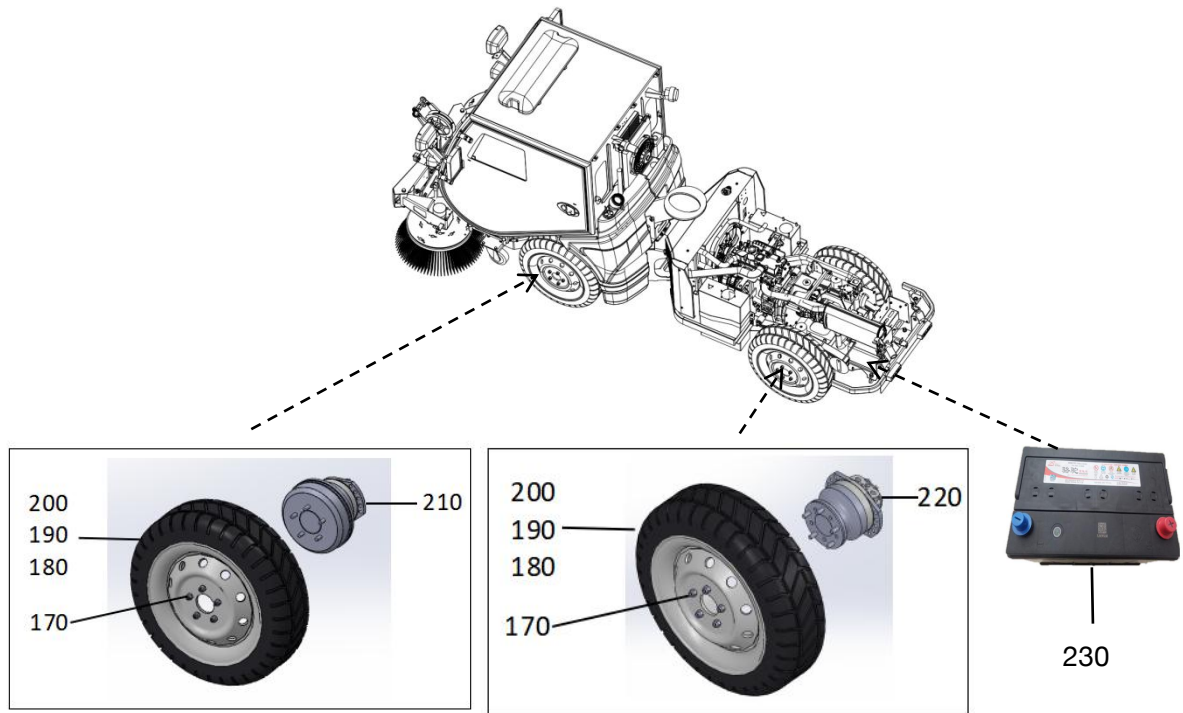

No.	Picture	Description	Material Code	Quantity
80		Left rear lights	06.B012	1
90		Right rear lights	06.B013	2
100		Arrow lamp	06.Z024	1



No.	Picture	Description	Material Code	Quantity
110		Hose reel	06.Z149	1
120		Fire hydrant close lid	B066	1
130		Water filter	E001	1
140		Mini water filter	06.E001	2
150		Fuel tank cap	B064	1
160		Diesel oil level sensor	B014	1





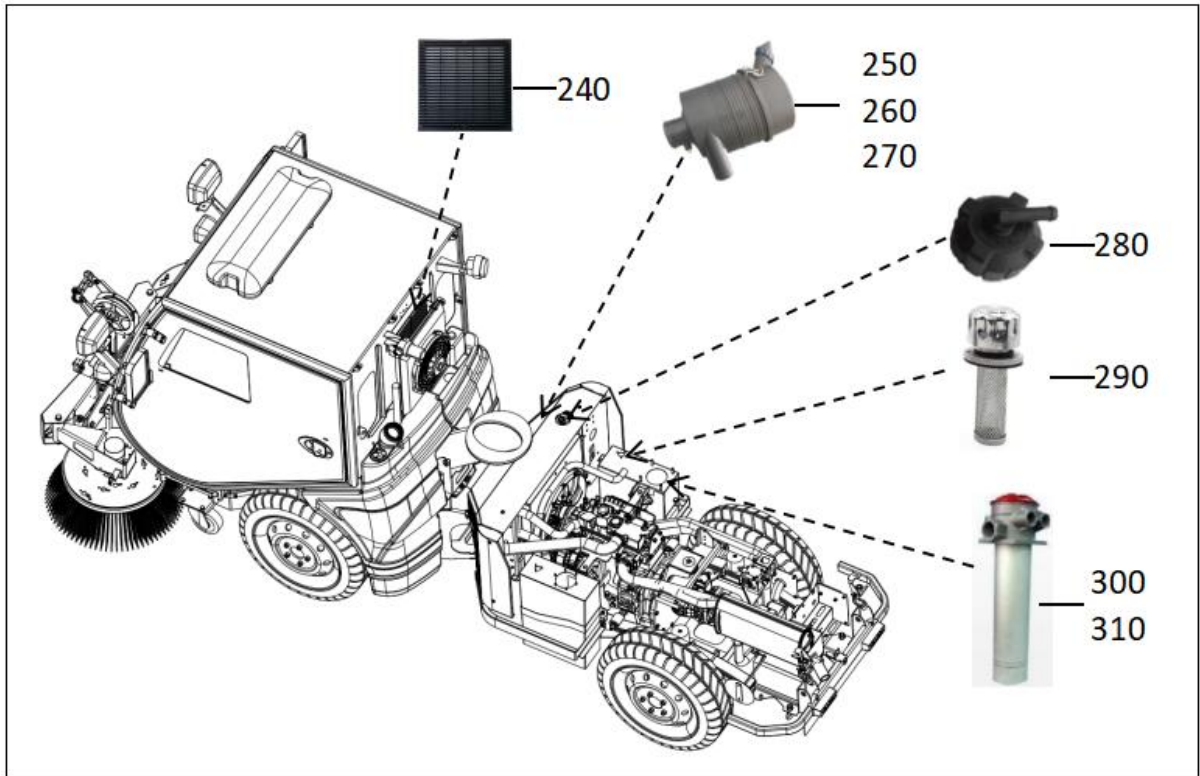

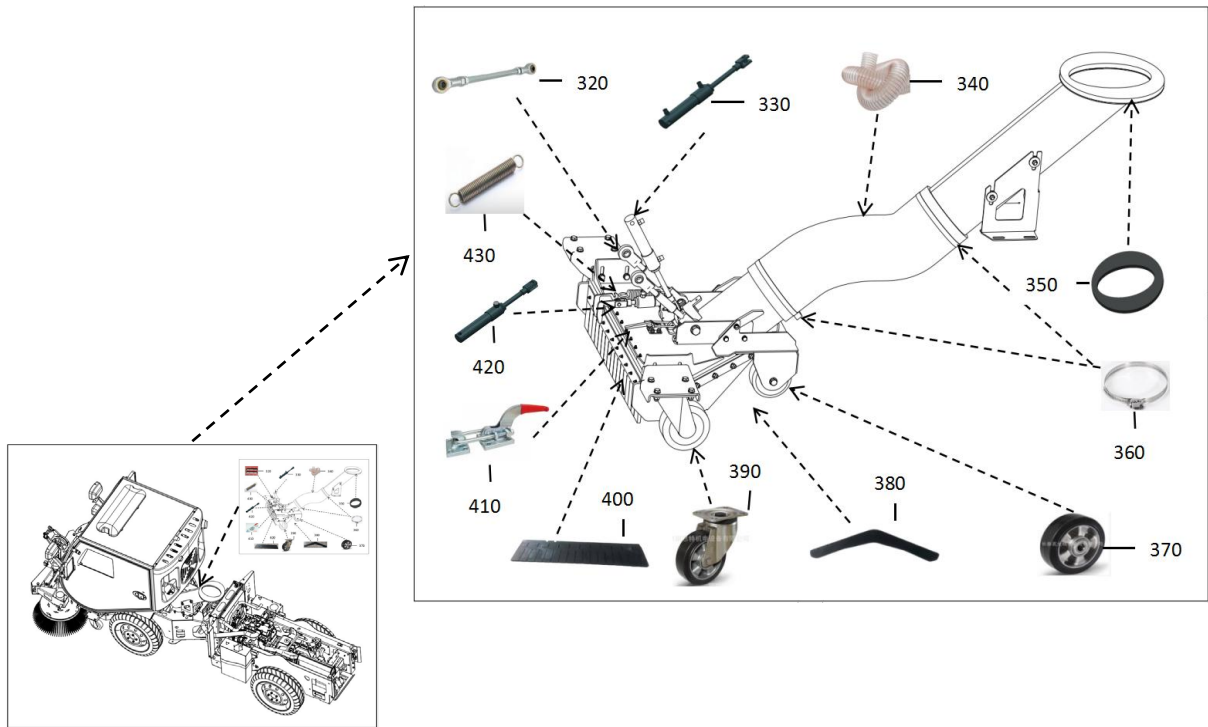

No.	Picture	Description	Material Code	Quantity
170		Hub nut	M14	20
180		Tyre	06.B010-01	4
190		Hub	06.B010-02	4
200		Hubcap	06.B010-02	4
210		Front walking motor	06.B081	2
220		Rear walking motor	06.B082	2
230		Battery	06.B049	1







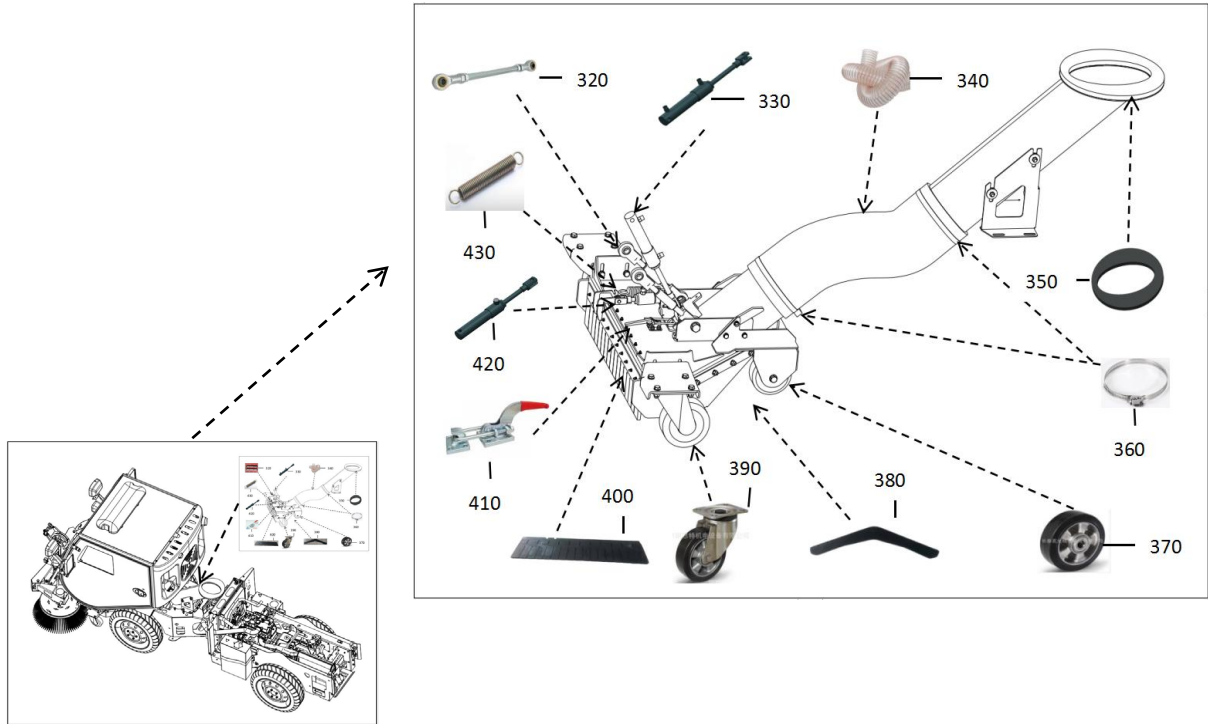

No.	Picture	Description	Material Code	Quantity
240		Ventilation filter	Z021	1
250		Air filter assembly	B009-01	1
260		Air filter element (outer core)	06.Z052	1
270		Air filter element (inner core)	06.Z051	1
280		Coolant expansion cap	06.B048	1
290		Air filter	B027-02	2
300		Suction back oil filter	B027	1
310		Suction back oil filter element	06.B027-03	1







No.	Picture	Description	Material Code	Quantity
320		connecting rod assembly	A022-03	2
330		Suction nozzle lifting cylinder	06.A045	1
340		Polyether steel wire pipe	B076-01	1
350		Suction tuyere straw pad	06.A036	1
360		Clamp	D218	2
370		Directional wheel	06.B035	2

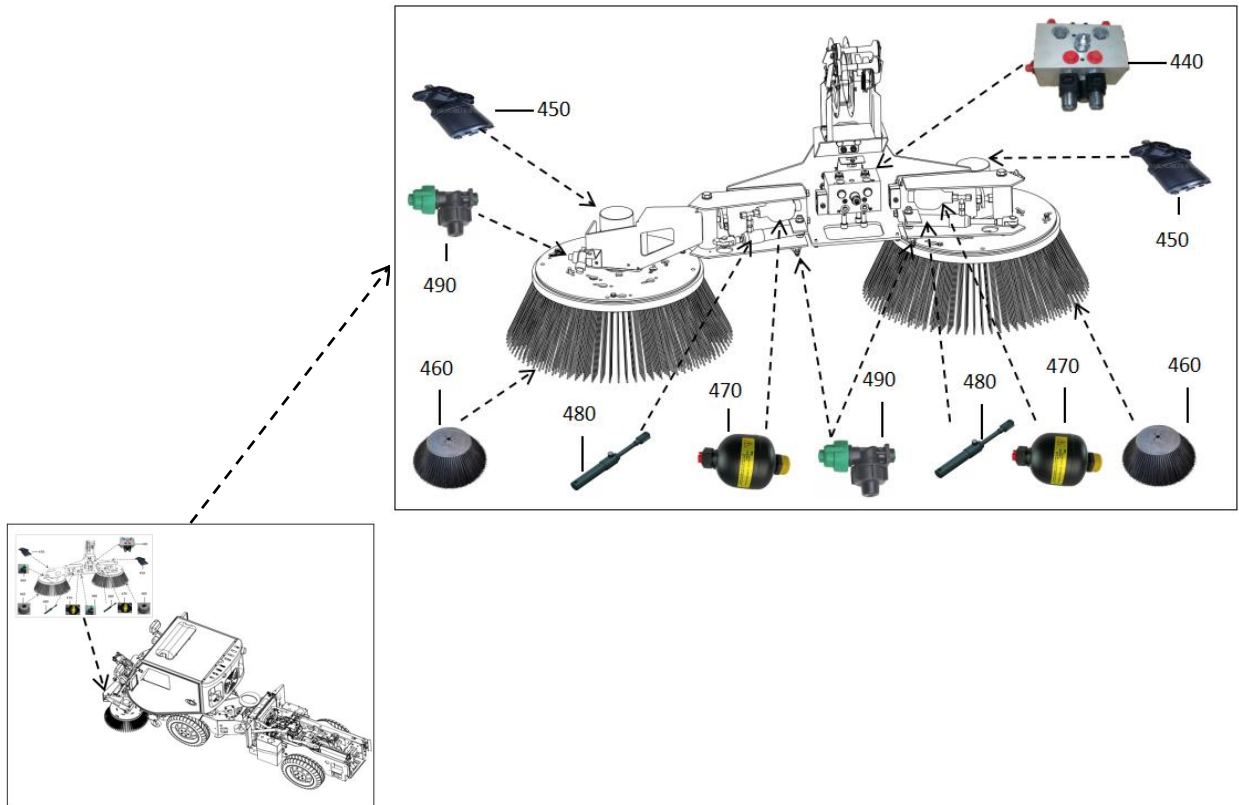

No.	Picture	Description	Material Code	Quantity
380		Rubber baffle plate behind suction outlet	06.A038	1
390		Directional wheel	06.B036	2
400		Rubber baffle plate before suction outlet	06.A039	1
410		Quick clip	06.B009	1
420		Baffle closing cylinder	06.A044	1
430		Tension spring of suction outlet	06.A049	1





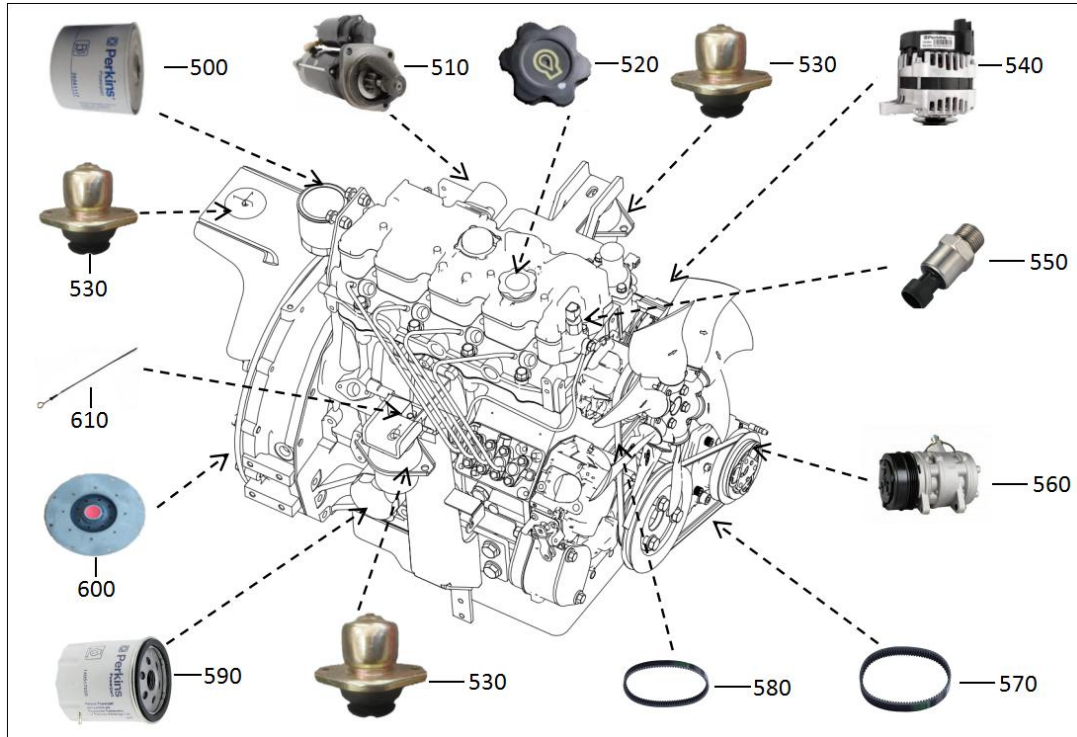

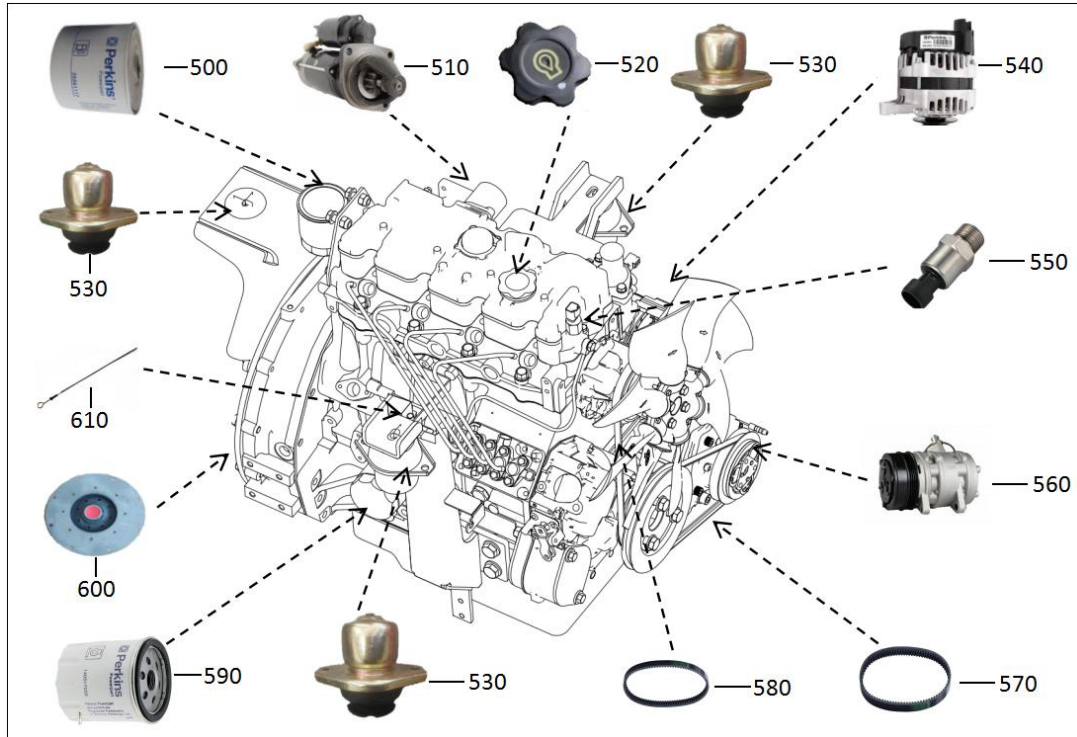

No.	Picture	Description	Material Code	Quantity
440		Opening and closing valve group of sweeping brush	06.B001	1
450		Brush motor	06.B038	2
460		Sweeping brush	B043	2
470		Energy accumulator	06.B037	2
480		Opening and closing oil cylinder for sweeping brush	06.A043	2
490		Brush nozzle with switch	06.A081	4





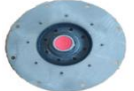

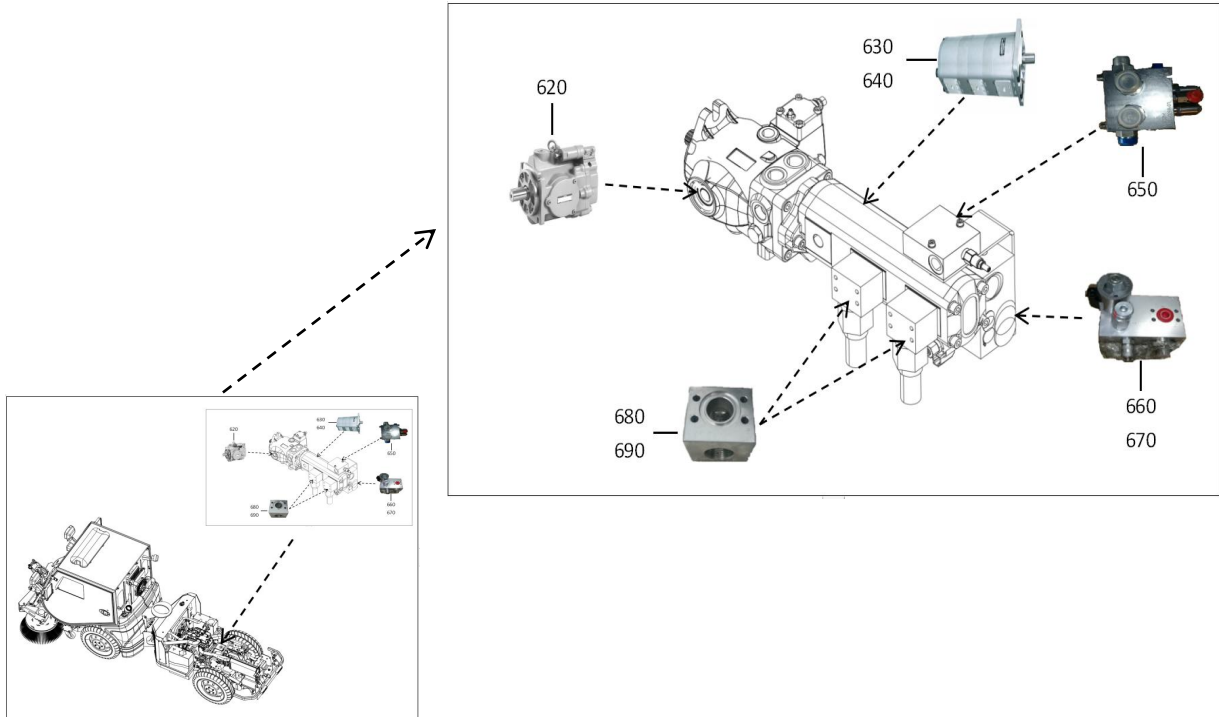

No.	Picture	Description	Material Code	Quantity
500		Diesel filter	06.S002	1
510		Starting motor	06.z029	1
520		Oil filter cap	006.L009	1
530		Engine shock absorber	B083	3
540		Dynamo	06.Z028	1
550		Engine oil pressure sensor	06.Z104	1





No.	Picture	Description	Material Code	Quantity
560		Compressor	06.B011-02	1
570		Compressor belt	06.B028	1
580		Engine fan belt	03.F061	1
590		Engine oil filter	06.S001	1
600		Coupling	06.B015	1
610		Engine Oil Dipstick	z095	1

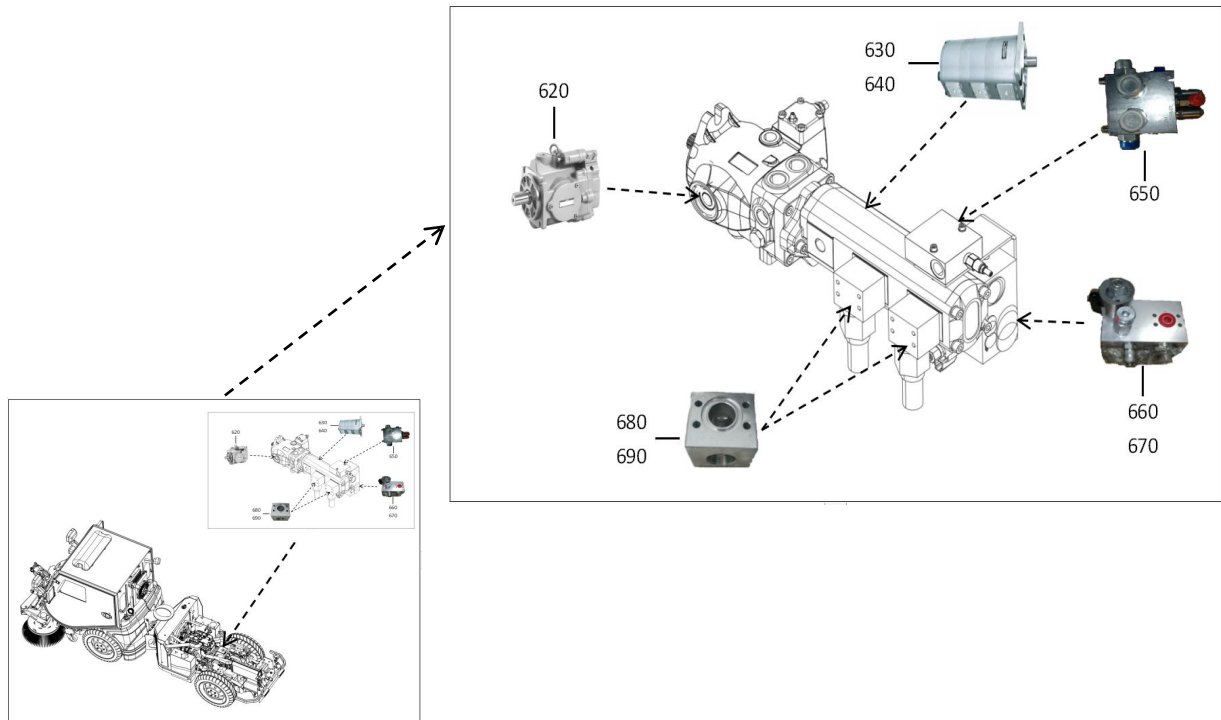

No.	Picture	Description	Material Code	Quantity
620		Walking pump	06.B034	1
630		Triple gear pump	06.B029-04	1
640		O ring	82.22*2.62	1
650		Walking cooling valve group	06.B005	1
660		Turbine valve block	06.B004	1
670		O ring	17.8*2.4	1





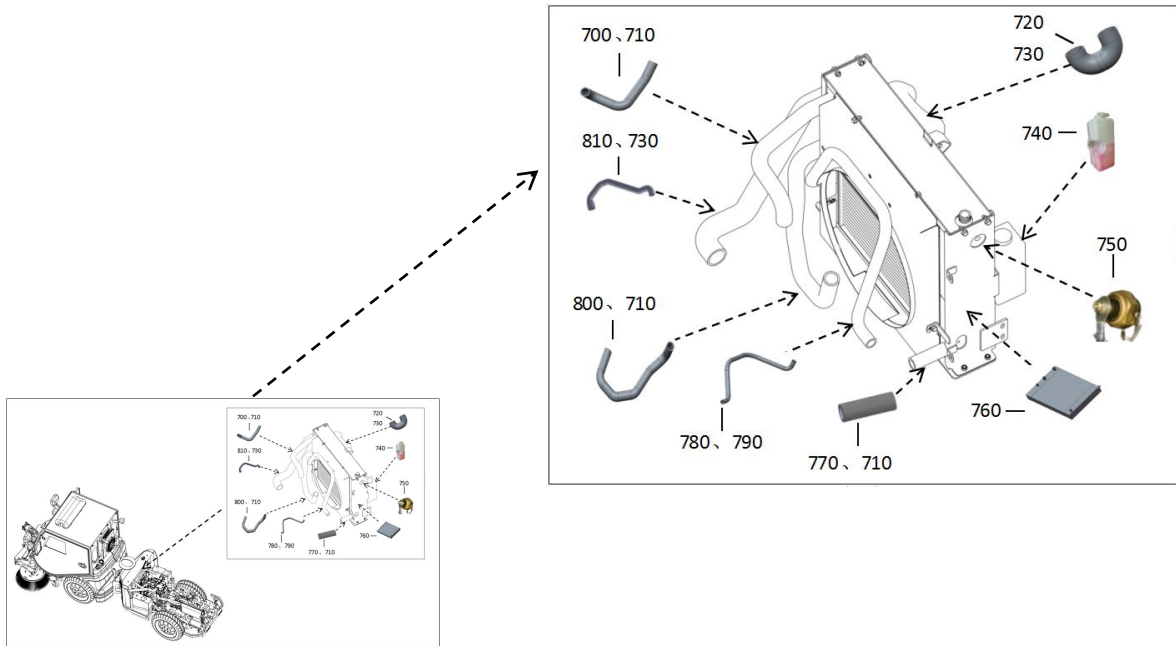

No.	Picture	Description	Material Code	Quantity
680		Oil suction flange	F002	2
690		O ring	30*3.55	2

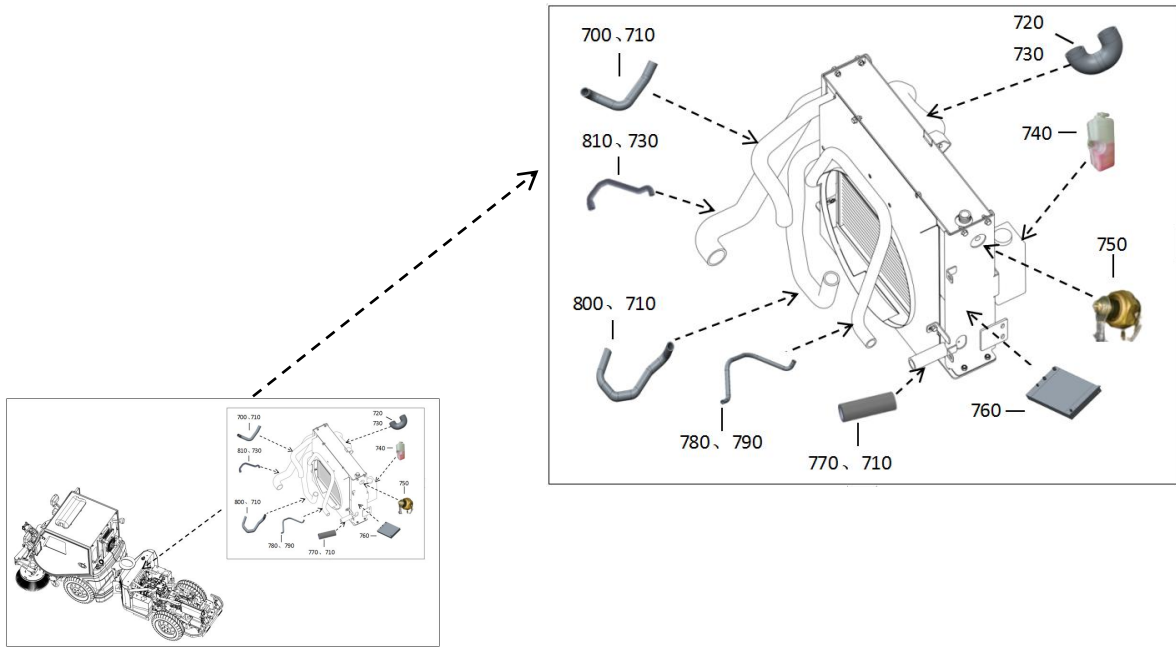





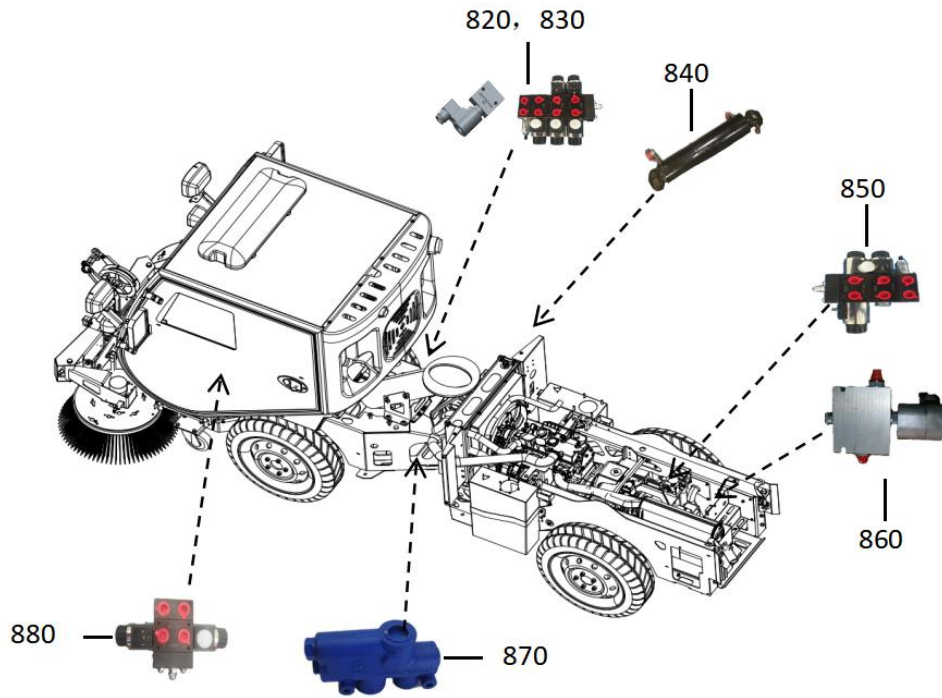

No.	Picture	Description	Material Code	Quantity
700		Rubber pipe (No.21)	06.A055	1
710		German type clamp	D274	6
720		Filter intake pipe	A060	1
730		German type clamp	D688	4
740		Cooling auxiliary kettle	06.B080	1
750		Temperature sensor	B011-10	1
760		Radiator	B041	1



No.	Picture	Description	Material Code	Quantity
770		Oil return pipe	A090	1
780		Heat dissipation tube (No. 19)	A053	1
790		German type clamp	D271	1
800		Heat dissipation tube (No. 20)	A054	1
810		Air filter tube	A059	1





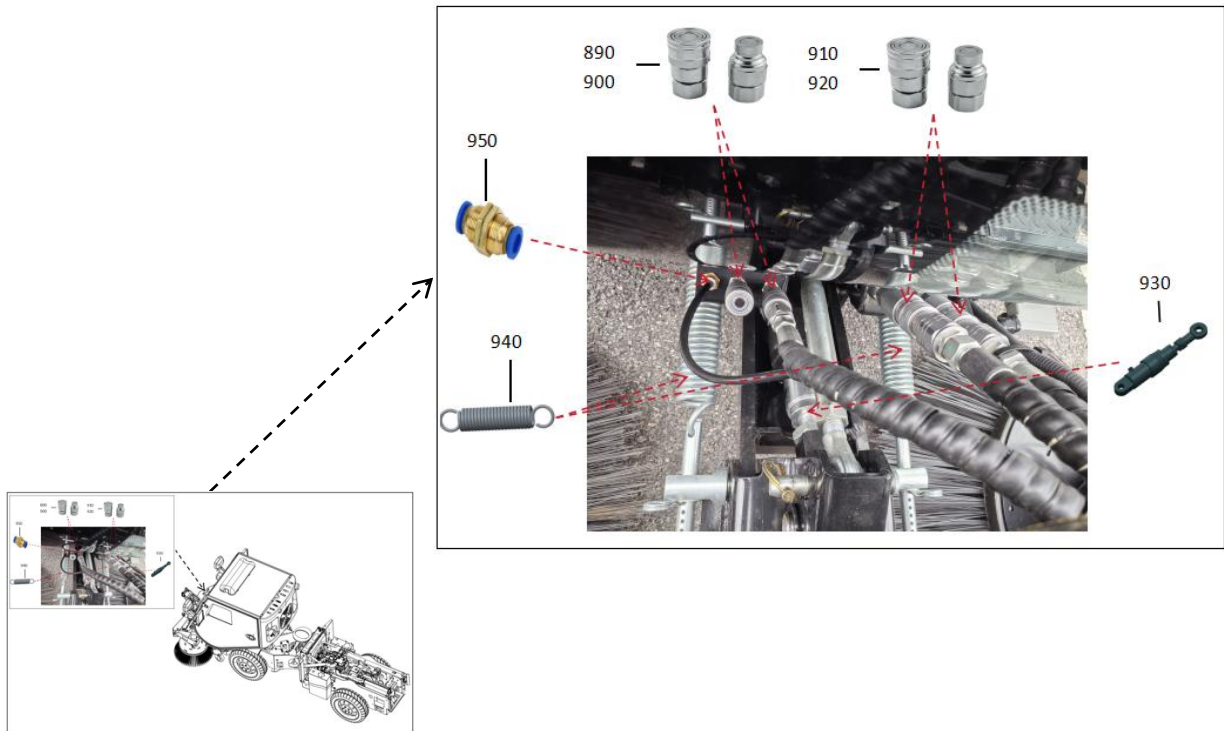

No.	Picture	Description	Material Code	Quantity
820		Solenoid ball valve	06.B007	1
830		Triple valve group	06.B031	1
840		Steering cylinder	06.A046	1
850		Dual valve group	06.B030	1
860		Pump motor control valve group	06.B003	1
870		Priority valve	B032	1
880		Single valve group	B030-01	1

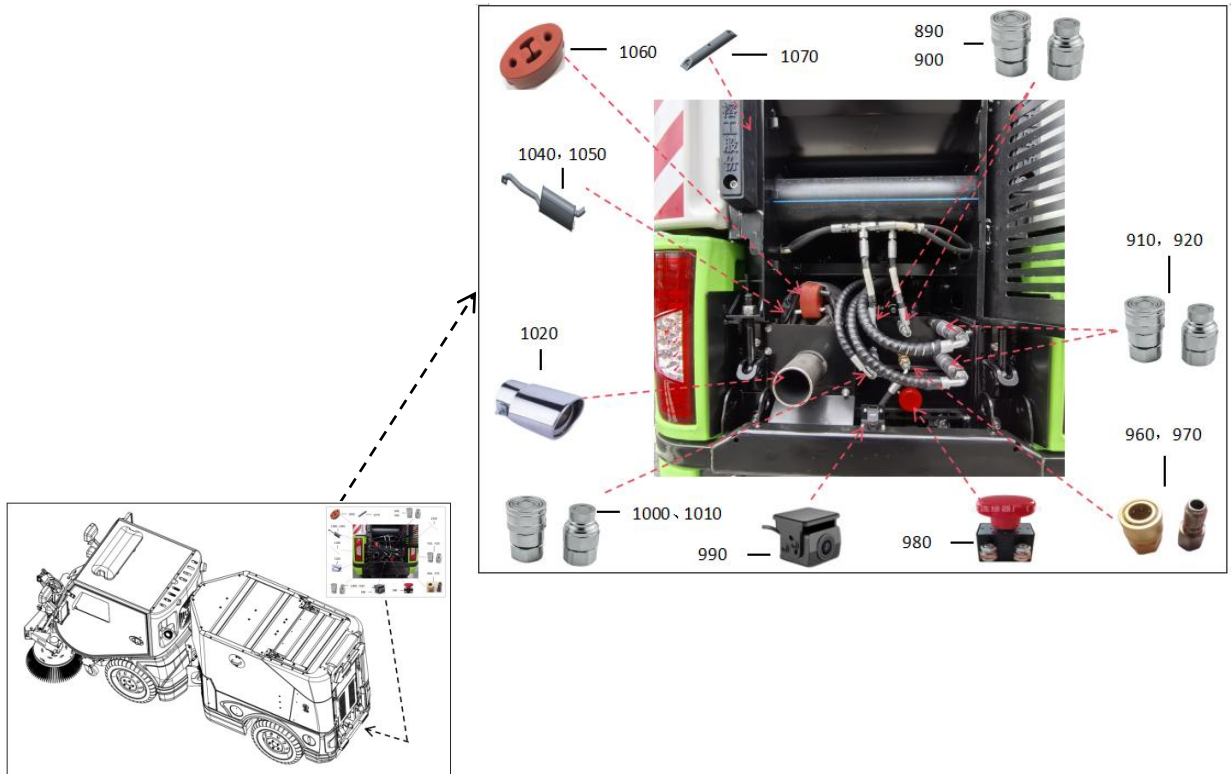





No.	Picture	Description	Material Code	Quantity
890		Quick connector 1 / 4 (female)	B084-02	4
900		Quick connector 1 / 4 (male)	B084-01	4
910		Quick connector 1 / 2 (female)	B085-02	4
920		Quick connector 1 / 2 (male)	B085-01	4
930		Lifting oil cylinder of sweeping brush	06.A042	1
940		Tension spring	06.A048	2
950		Bulkhead connector	06.E019	1

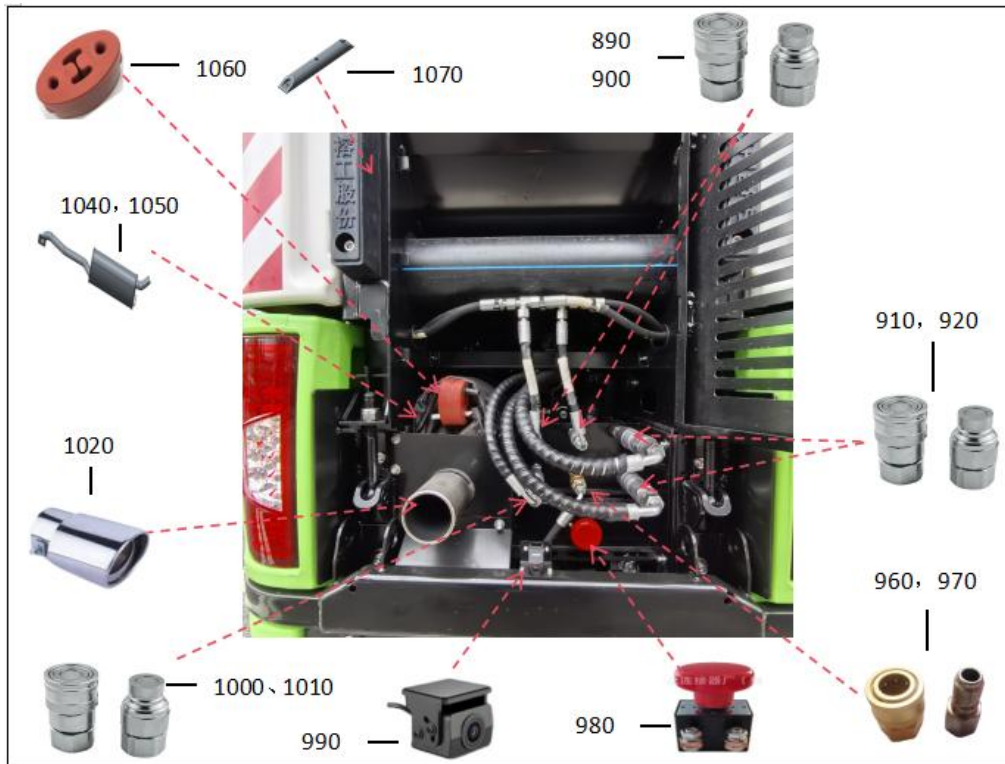

No.	Picture	Description	Material Code	Quantity
960		Quick connector A	E002	2
970		Quick connector B	E003	1
980		Emergency stop switch	06.Z026	1
990		Driving recorder -camera	06.Z224-2	1
1000		Quick connector 3/8 (female)	B086-03	1
1010		Quick connector 3/8 (male)	B086-02	1





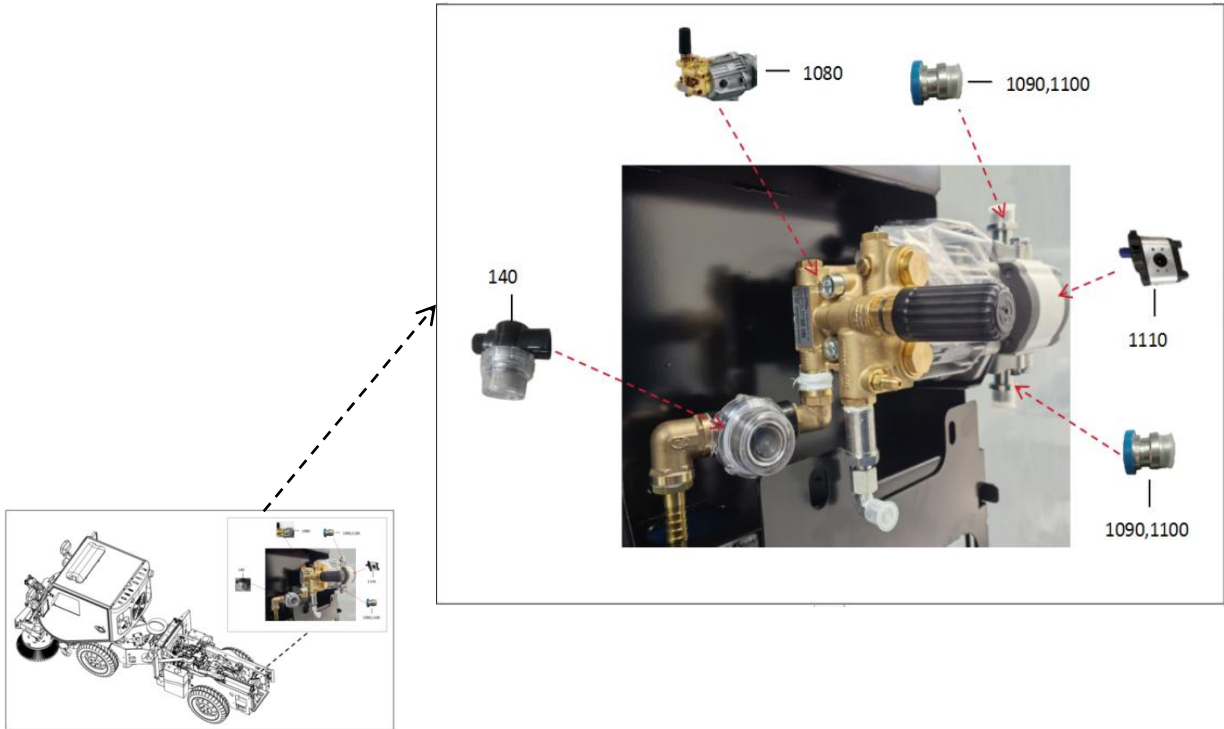

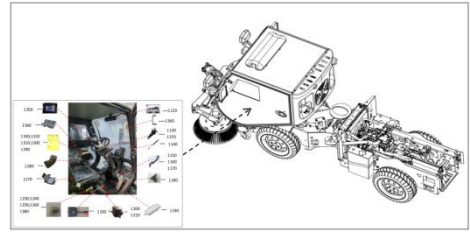
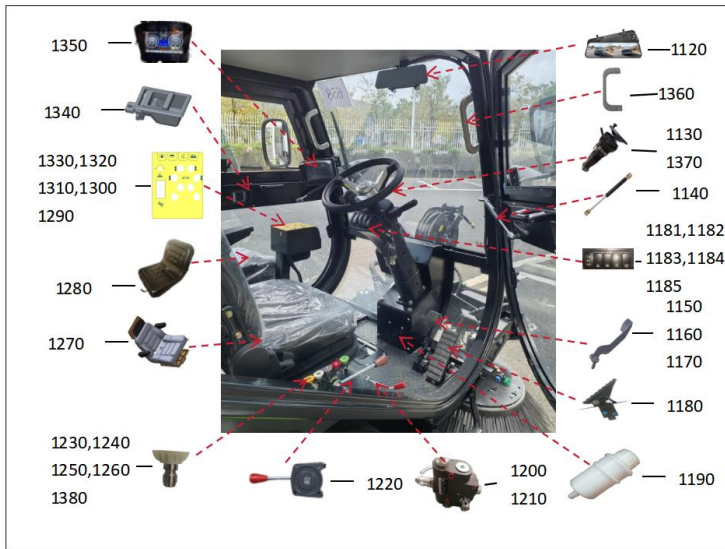

No.	Picture	Description	Material Code	Quantity
1020		Exhaust tail muffler	Z215	1
1040		Muffler	06.A050	1
1050		Insulation package	06.B104	1
1060		Exhaust hanger	B067	1
1070		Anti-collision bar	B046-01	2







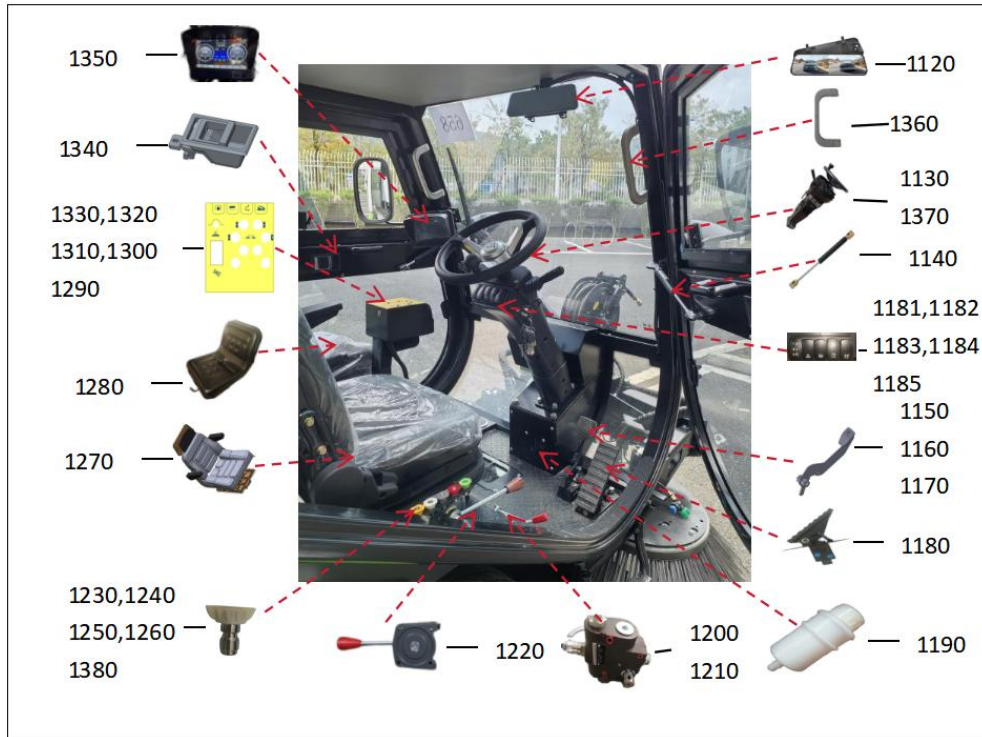

No.	Picture	Description	Material Code	Quantity
1080		High pressure pump	06.b024	1
1090		Flange joint	D027-1	2
1100		O ring	D027-2	2
1110		Gear motor	06.B029-03	1







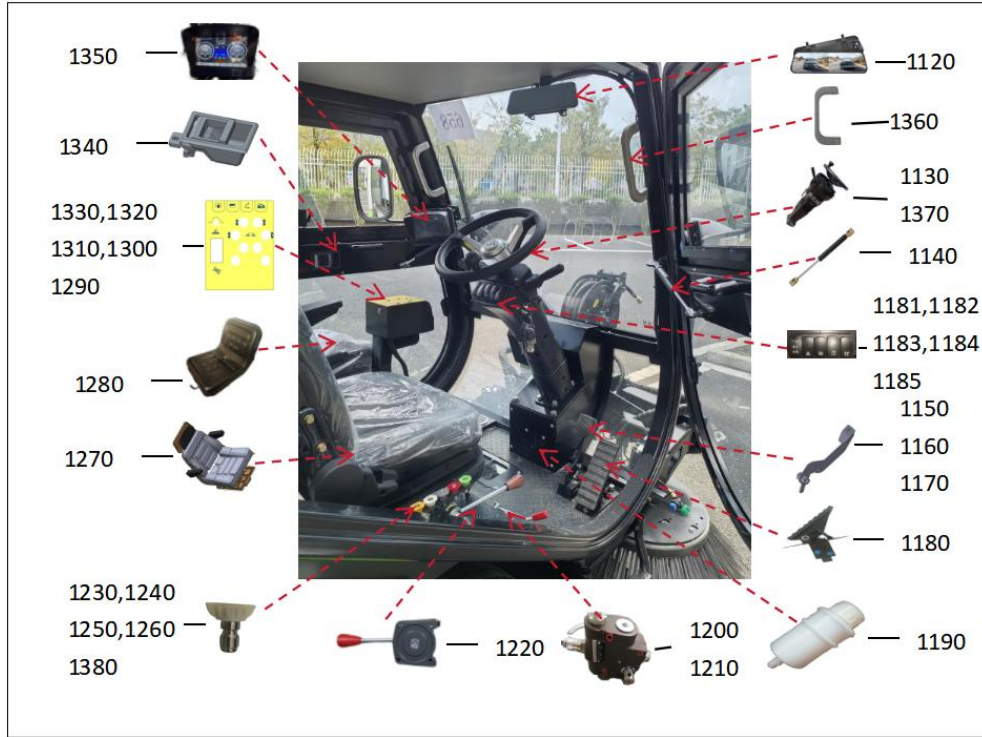

No.	Picture	Description	Material Code	Quantity
1120		Driving recorder	06.Z224-1	1
1130		Steering machine instrument	06.A067-1	1
1140		Cab gas spring	06.A001-40	2
1150		Foot brake pedal assembly	A001-16	1
1160		Brake pump	B088	1
1170		Brake pump cover	Z096	1



No.	Picture	Description	Material Code	Quantity
1180		Walking foot valve	B017-03	1
1190		Brake oil tank	B089	1
1200		Manual speed control valve	06.B031-01	1
1210		Operating lever of speed control valve	B128	1
1220		Throttle cable handle	06.A001-67	1
1230		Spray nozzle 0 degrees	B069-03	1





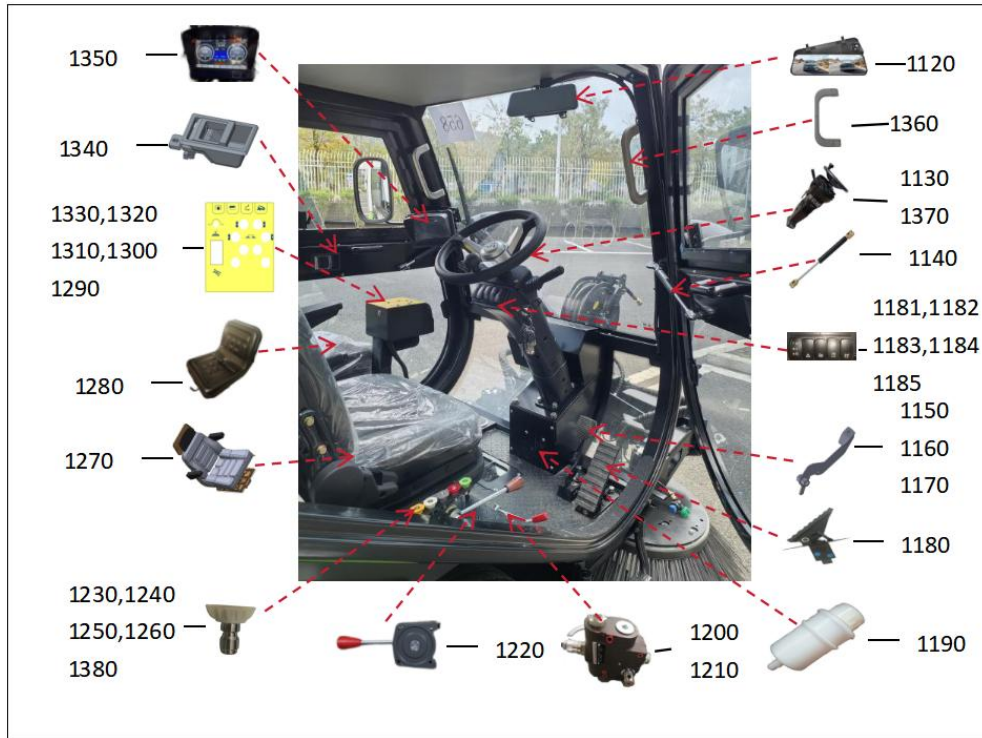



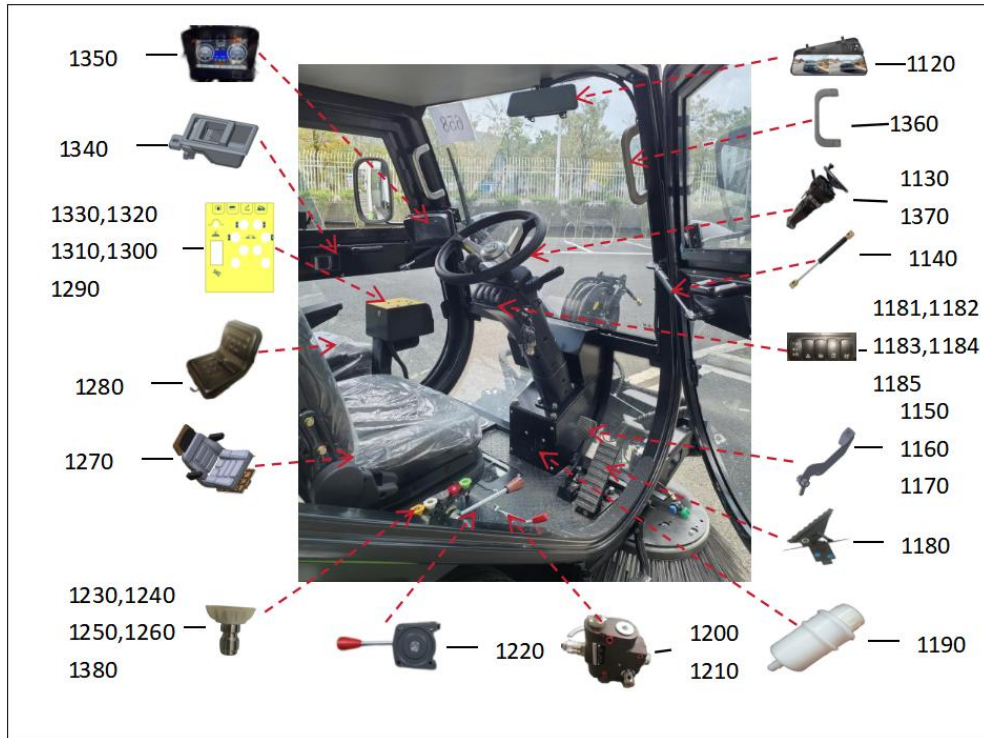

No.	Picture	Description	Material Code	Quantity
1240		Spray head 15 degrees	B069-04	1
1250		The nozzle 25 degrees	B069-02	1
1260		The nozzle 40 degrees	B069-05	1
1270		Main driving seat	B042	1
1280		Copilot seat	B047	1
1290		Control panel labeling	RG · 3500.2.32.4	1



No.	Picture	Description	Material Code	Quantity
1300		Self-reset button switch	A077	6
1310		Self-locking button switch	A078	1
1320		Self-resetting warping switch	A075	3
1330		Self-locking warping switch	A076	1
1340		Interior handle	Z022	2
1350		Screen	06.A067-2	1



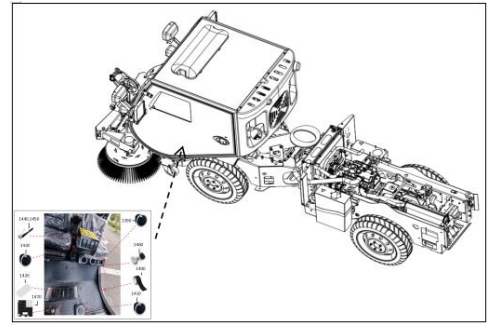
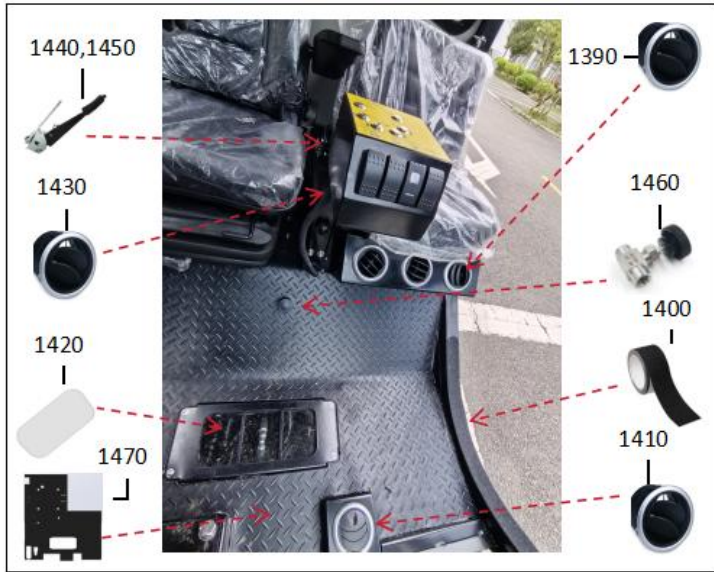

No.	Picture	Description	Material Code	Quantity
1360		Cabin armrests	A001-63	2
1370		Steering device	06.B033	1
1380		Spray head 65 degrees	B069-07	1
1181		Forward/Reverse switch	06.A067-1-1	1
1182		Warning lamp switch	06.A067-1-2	1
1183		A/C blower speed switch	06.A067-1-3	1
1184		A/C cooling/heating switch	06.A067-1-4	1
1185		Safety warning lamp switch	06.A067-1-5	1

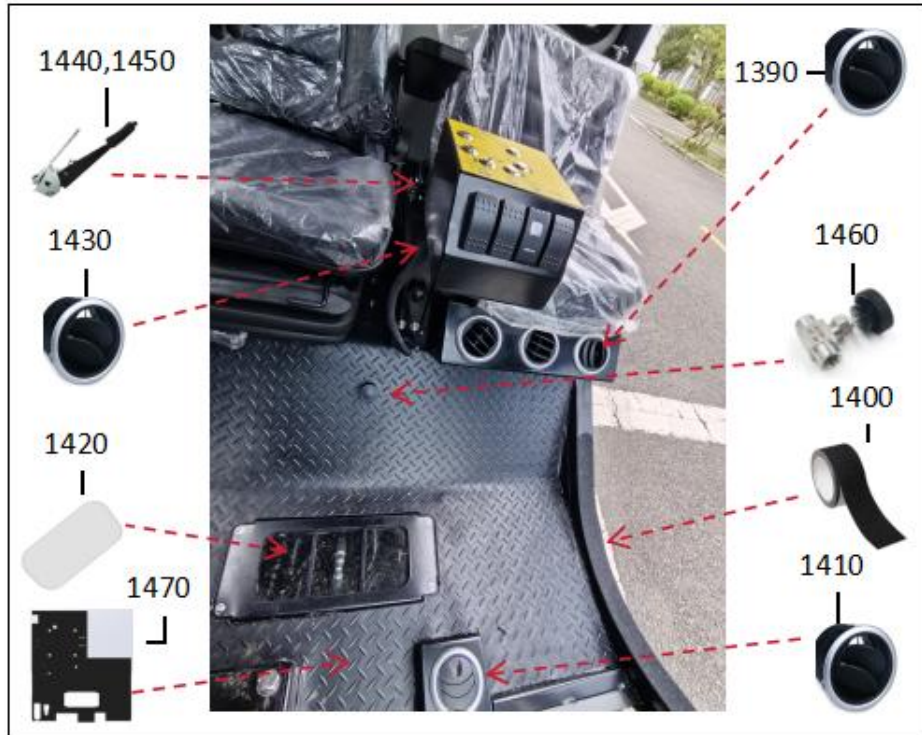

No.	Picture	Description	Material Code	Quantity
1390		Air conditioning Vent A (Straight head)	A001-58	3
1400		Non-slip tape	5cm	2
1410		Air conditioning vent B (elbow)	A001-59	1
1420		Window glass	06.A001-41	1
1430		Air conditioning outlet	B011-12	1
1440		Handbrake lever	A001-66	1



No.	Picture	Description	Material Code	Quantity
1450		Hand brake switch	B094	1
1460		Stainless steel throttle valve	06.E010	1
1470		Diamond PVC foot pedal	B125-1	1

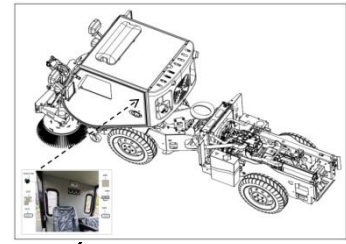

No.	Picture	Description	Material Code	Quantity
1480		Cab interior 1	B125-2	1
1490		Driving light	06.A001-65	1
1500		Cab glass 3	A001-3	1
1510		Cab glass 4	A001-4	1
1520		Cab interior 2	B125-3	1
1530		Air-conditioning vent C (small)	A001-60	3
1540		Ventilation filter	Z021	1





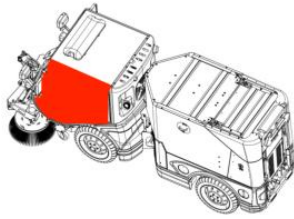

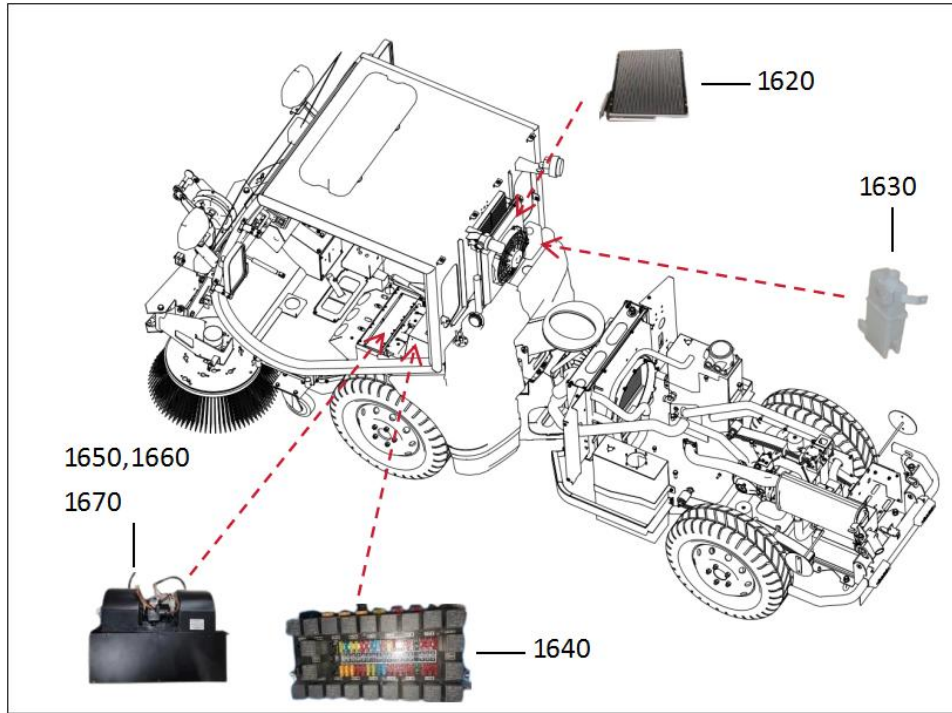

No.	Picture	Description	Material Code	Quantity
1550		Cab front glass (top)	06.A083	1
1560		Cab front glass (bottom)	06.A084	1
1570		Cab door edge guard	B130	2
1580		Right door glass	A001-2A	1
1590		Cab door lock assembly	Z033	2
1600		Cab window glass	A001-2C	2



No.	Picture	Description	Material Code	Quantity
1610		Left door glass	A001-2B	1





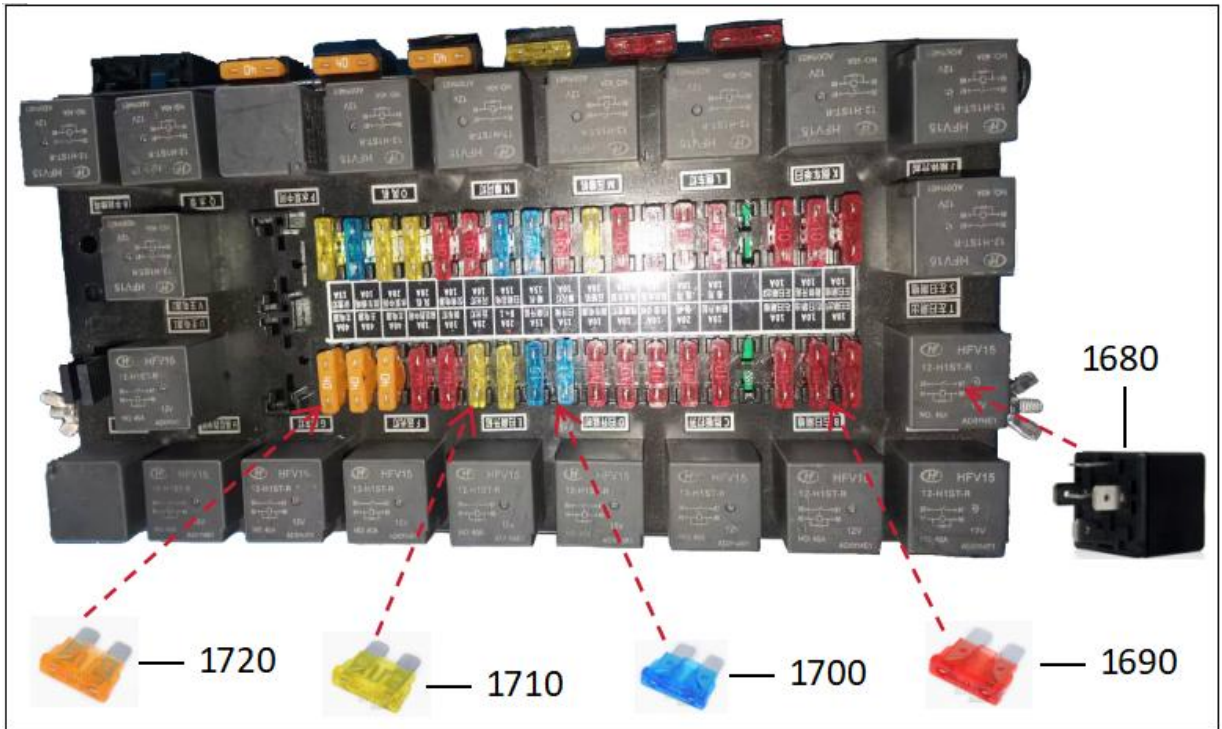

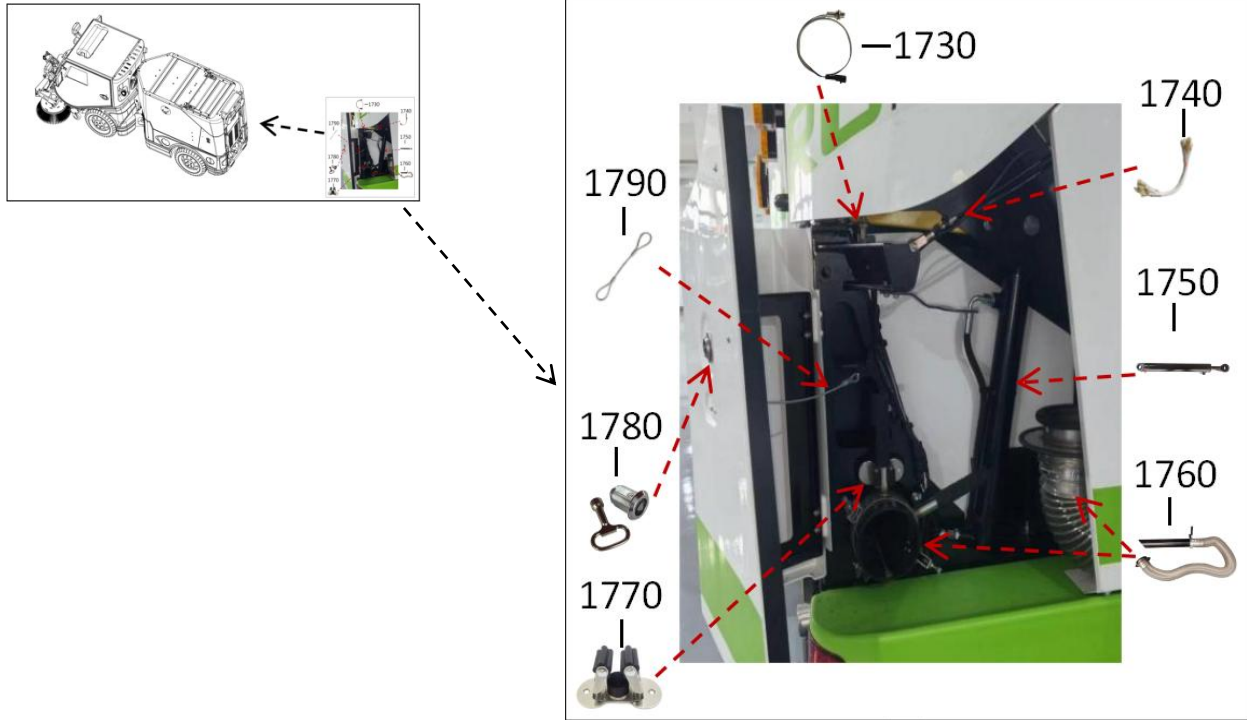

No.	Picture	Description	Material Code	Quantity
1620		Air conditioning condenser	B011-02	1
1630		Wiper kettle	A001-44C	1
1640		Relay assembly	A069	1
1650		Air conditioning evaporator	B011-04	1
1660		Temperature control switch	B011-10	1
1670		Water valve switch	B011-03	1



No.	Picture	Description	Material Code	Quantity
1680		Relay	A069-1	22
1690		10A fuse	A069-2	22
1700		15A fuses	A069-3	5
1710		20A fuses	A069-4	7
1720		40A fuses	A069-5	6





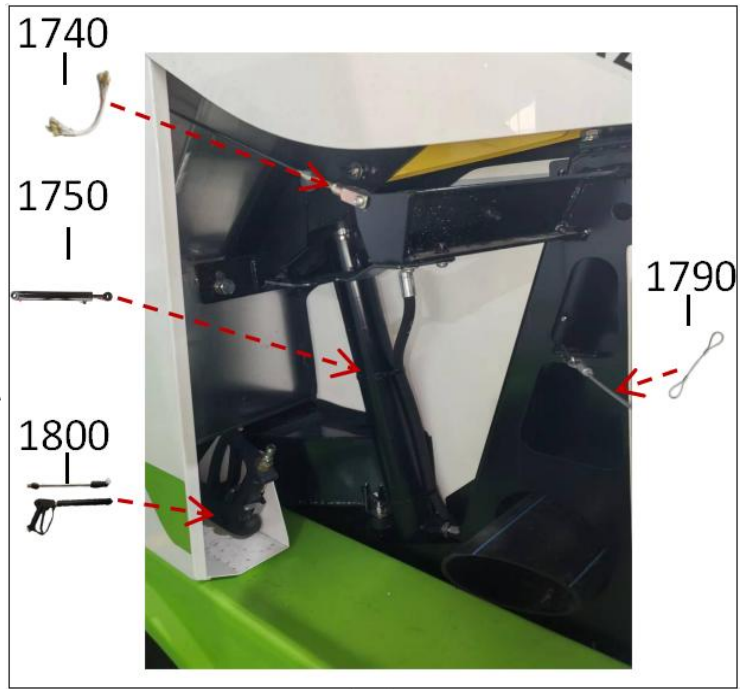
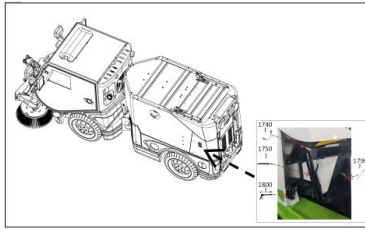

No.	Picture	Description	Material Code	Quantity
1730		Proximity switch	B091	1
1740		Steel wire rope for recycling bin	A062	2
1750		Box lift cylinder	A041	2
1760		Hand-held tube	B075	1
1770		Fixed clip	Z034	1
1780		Triangle lock	Z159	2
1790		Steel wire rope	L001	2

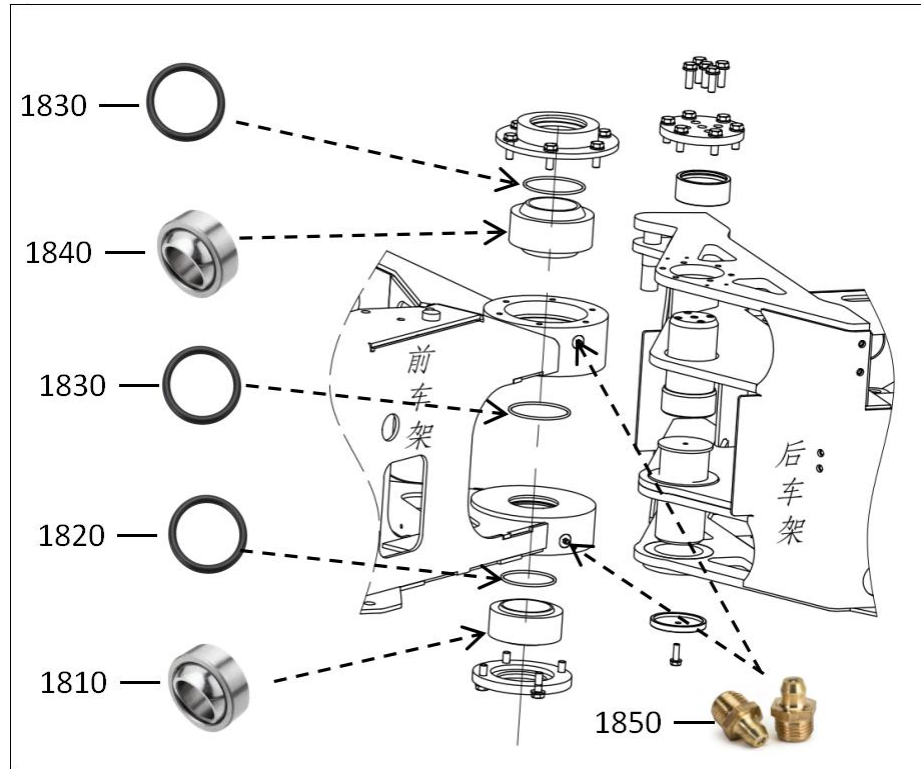
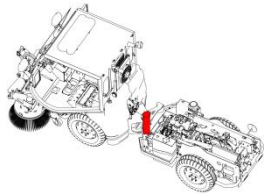





No.	Picture	Description	Material Code	Quantity
1800		High-pressure water gun	B069	1

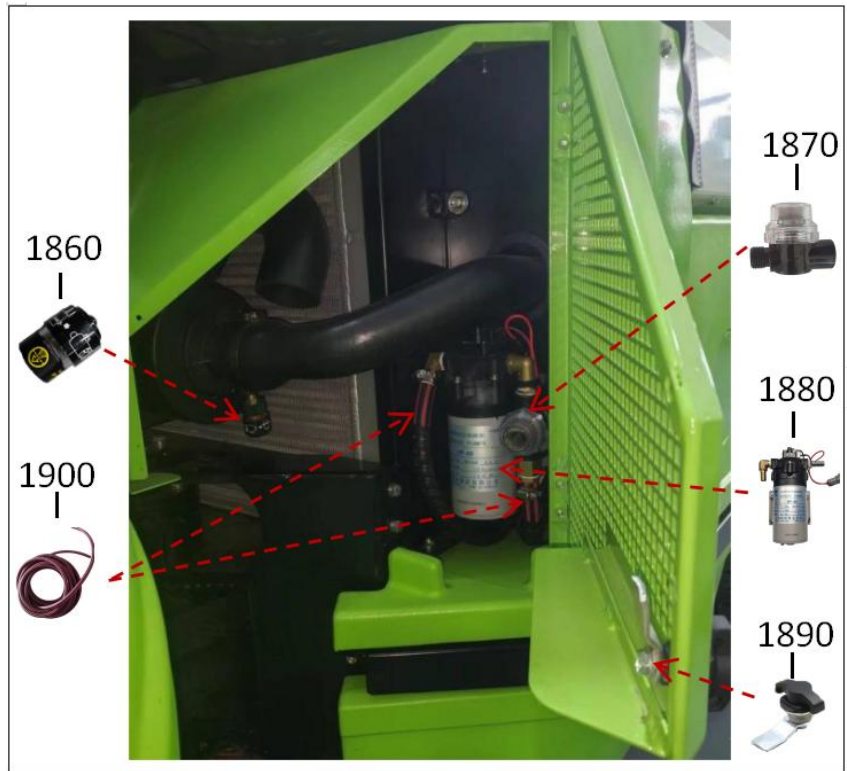
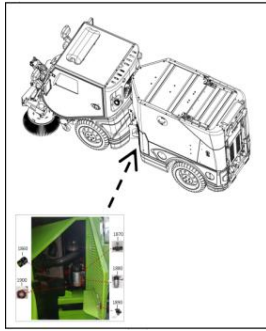





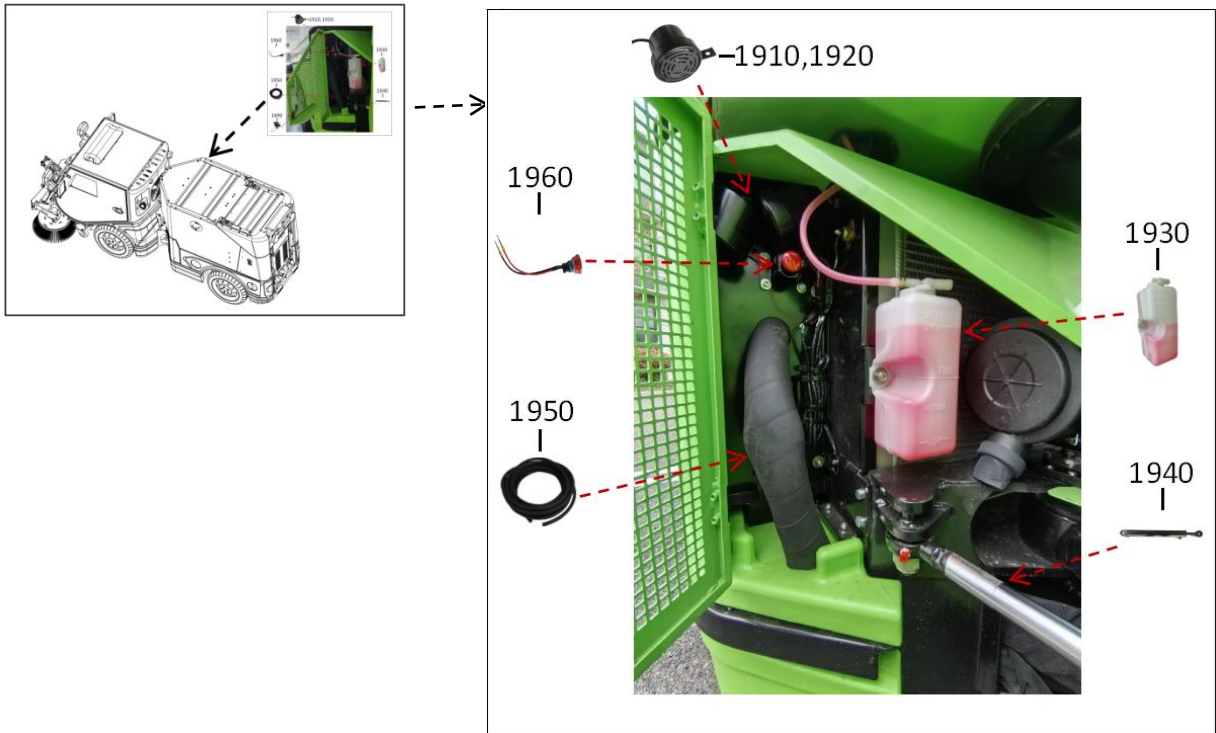

No.	Picture	Description	Material Code	Quantity
1810		Joint bearing 1	B040-01	1
1820		O ring	D164	1
1830		O ring	D163	2
1840		Joint bearing 2	B040-02	1
1850		Grease fitting	D401	1



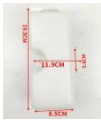



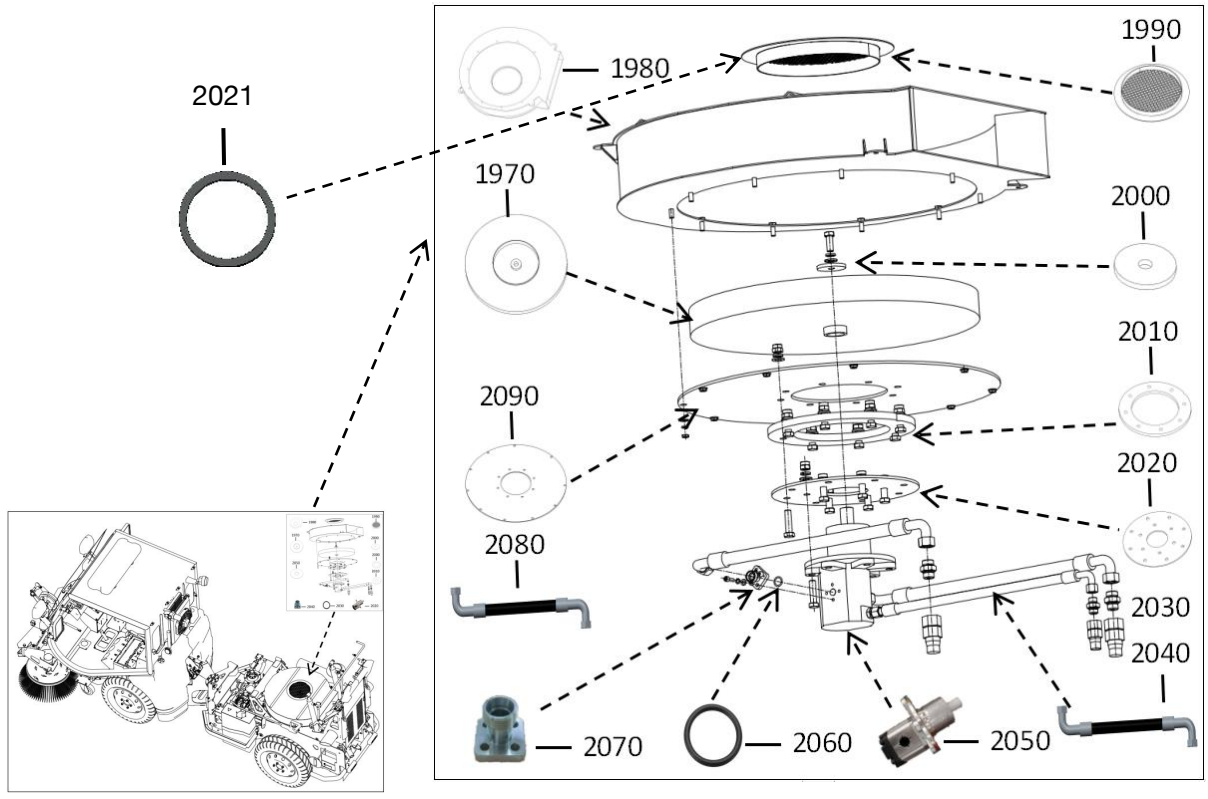

No.	Picture	Description	Material Code	Quantity
1860		Electronic alarm	B009-03	1
1870		Mini filter	E001-01	1
1880		Diaphragm pump	B121	1
1890		Door lock	B071	2
1900		Water pipe	C112	2



No.	Picture	Description	Material Code	Quantity
1910		Voice speaker (sewage discharge)	Z023-04	1
1920		Voice speaker (baking-up attention)	Z023-03	1
1930		Coolant auxiliary water tank	B080	1
1940		Steering cylinder	A046	1
1950		Rubber water pipe	06.P007	1
1960		Emergency stop switch	06.P006	1





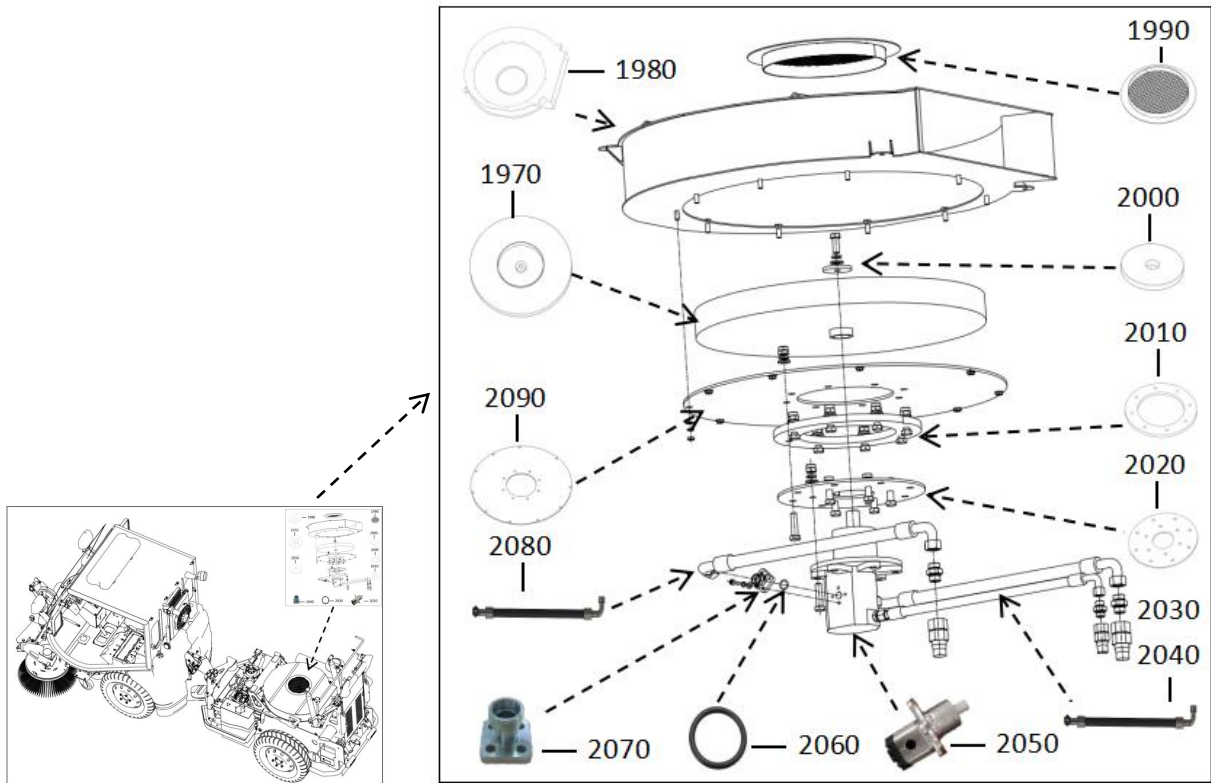

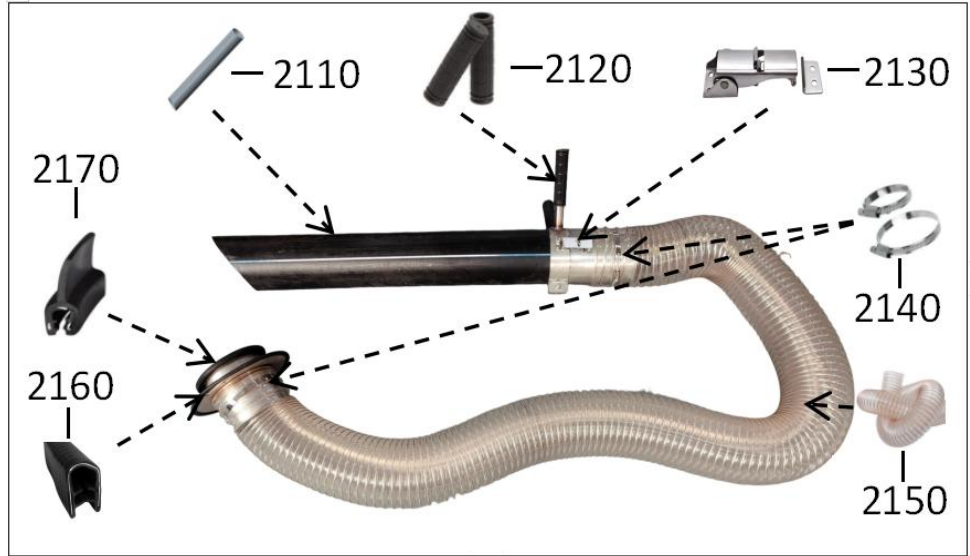
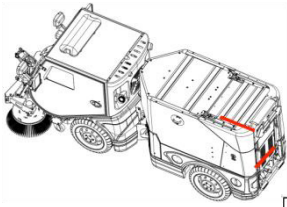

No.	Picture	Description	Material Code	Quantity
1970		Fan blade assembly	A005-29	1
1980		Fan case	A005-53A	1
1990		Filter screen	A005-53B	1
2000		Fan impeller gasket	A005-53C	1
2010		Fan motor mounting plate 3	A005-53D	1
2020		Fan motor mounting plate 2	A005-53E	1
2021		Gasket of fan	A036-01	1



No.	Picture	Description	Material Code	Quantity
2030		Hydraulic hose	JG8240-L13	1
2040		Hydraulic hose	JG8240-L14	1
2050		Fan motor	B029-01	1
2060		O ring	C092	2
2070		Square flange	F005	2
2080		Hydraulic hose	JG8240-L12	1
2090		Fan motor mounting plate 1	A005-53E	1





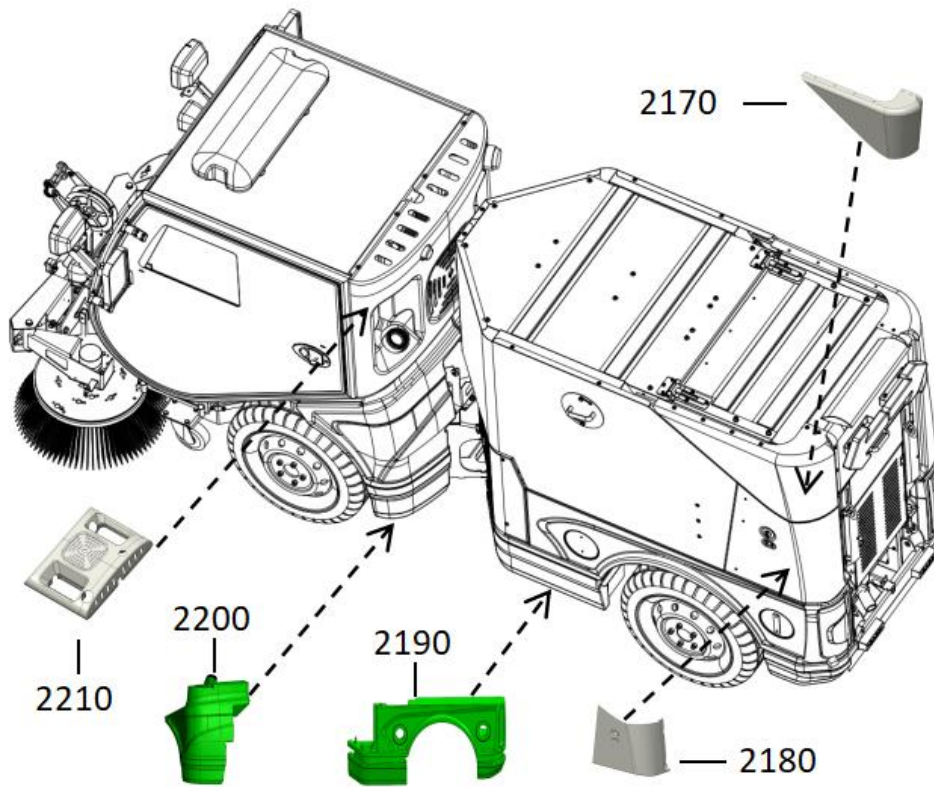

No.	Picture	Description	Material Code	Quantity
2110		Nylon Tube	B073	1
2120		Vacuum hard tube handle	B074	2
2130		Threaded adjustment buckle	B134	1
2140		Steel wire vacuum pipe A	B075	2
2150		German type clamp	D242	1
2160		Edge protector for sheet metal	B054	1

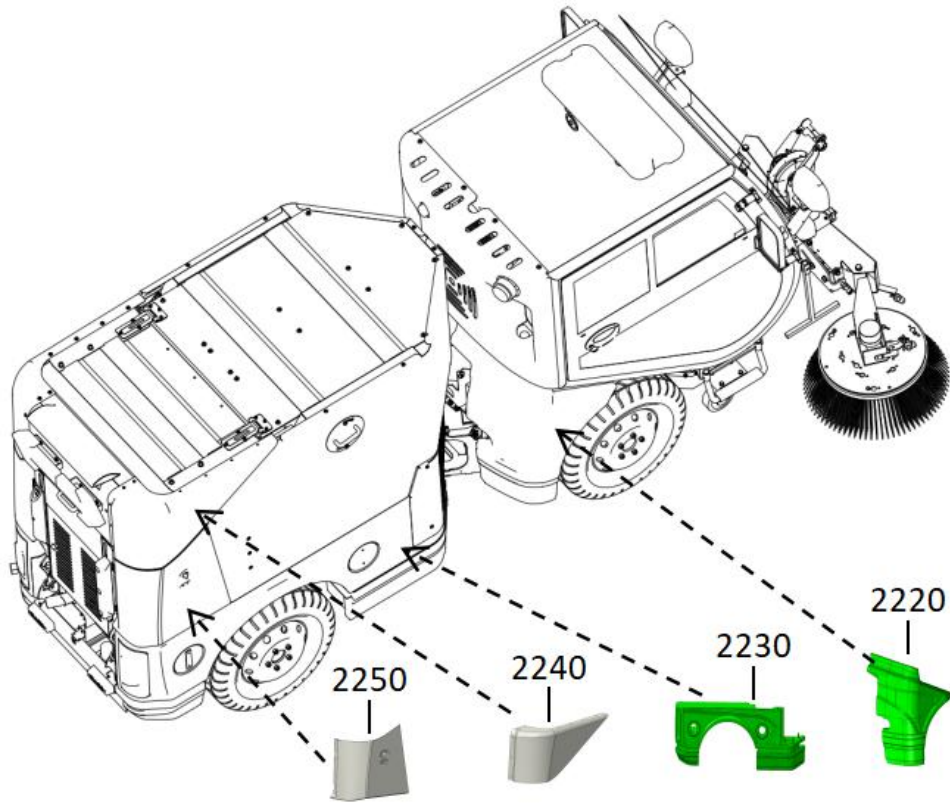





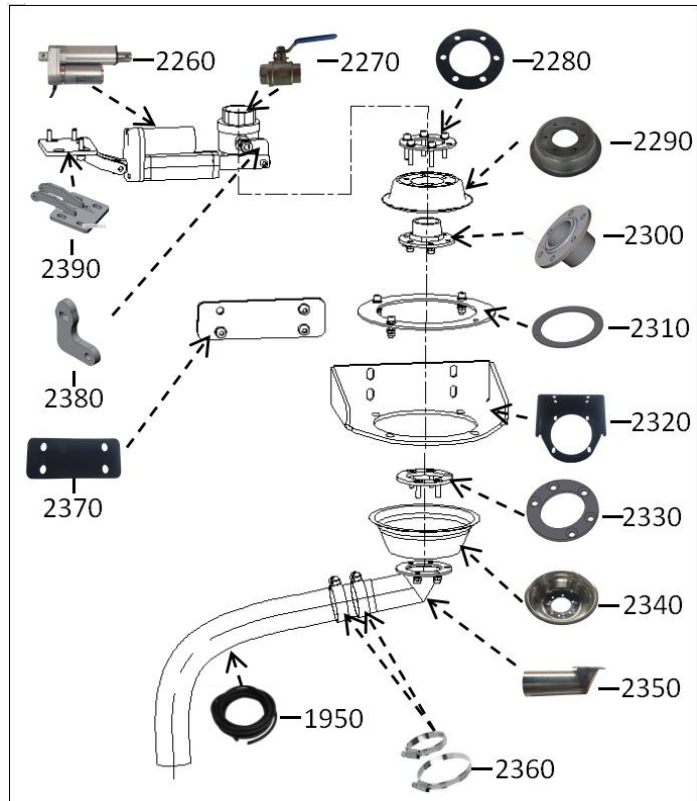
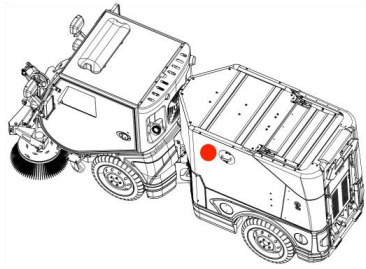

No.	Picture	Description	Material Code	Quantity
2170		Rear lower cover of recycling bin (left)	06.A026	1
2180		Rear cover door of recycling bin (left)	06.A028	1
2190		Left rear water tank	06.A030	1
2200		Left fuel tank	06.A032	1
2210		Cab rear cover blister parts	06.A003	1



No.	Picture	Description	Material Code	Quantity
2220		Right front water tank	06.A033	1
2230		Right rear water tank	06.A031	1
2240		Rear lower cover of recycling bin (right)	06.A027	1
2250		Rear cover door of recycling bin (right)	06.A029	1



No.	Picture	Description	Material Code	Quantity
2260		Electric Pushing Rod	06.P002	1
2270		Handle ball valve	B018	1
2280		Fixed piece on rubber part	06.P001	1
2290		Rubber seal	06.P012	1
2300		Welding flange	06.P001	1
2310		Lower funnel pressure plate	06.P001	1

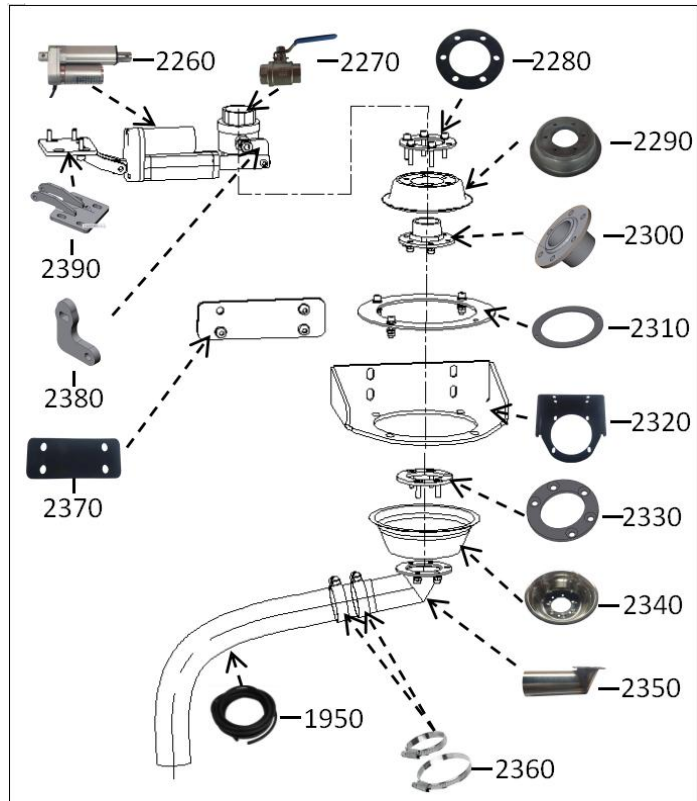
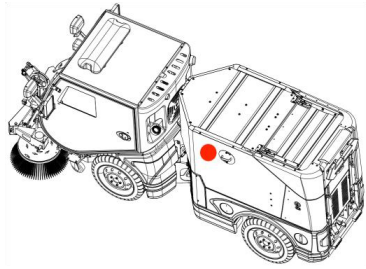

No.	Picture	Description	Material Code	Quantity
2320		Mounting base	06.P001	1
2330		Upper flange of drainage pipe	06.P001	1
2340		Stainless steel bowl	06.P014	1
2350		Stainless steel pipe	06.P010	1
2360		Stainless steel clamps	06.P013	2
2370		Adjusting plate		1

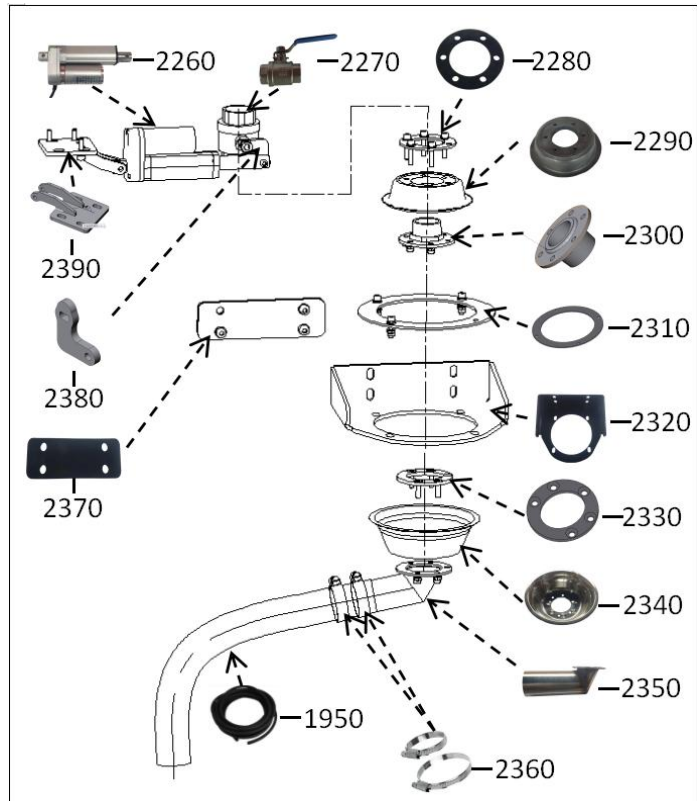
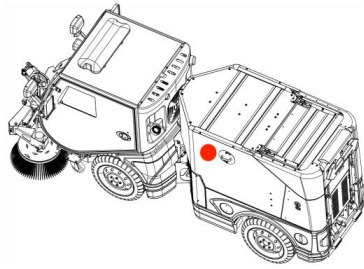

No.	Picture	Description	Material Code	Quantity
-----	---------	-------------	---------------	----------

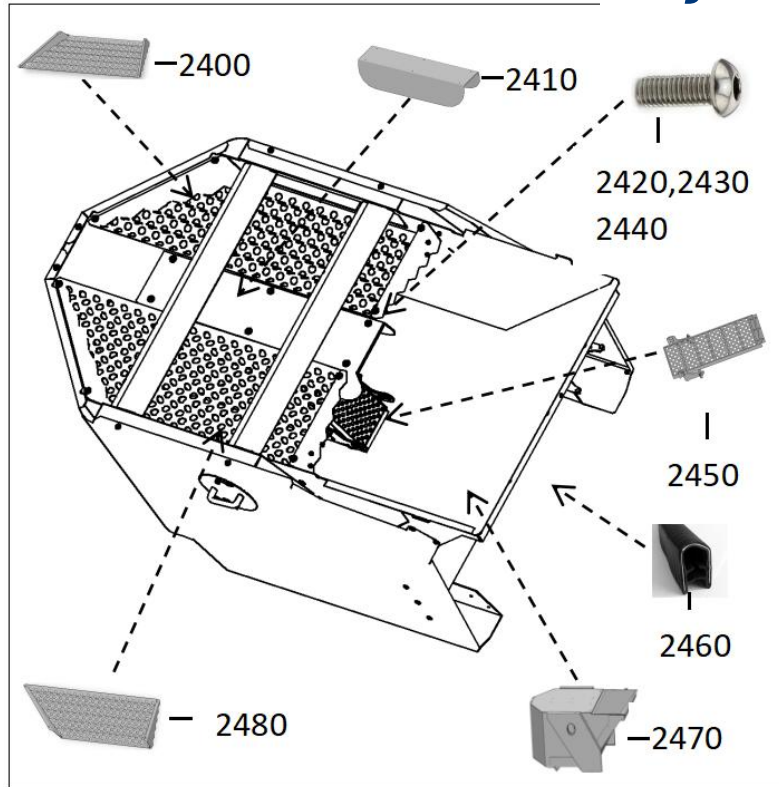
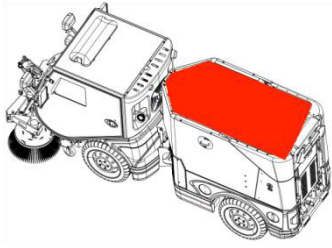

2380		Rotating rod	06.P001	1
------	---	--------------	---------	---

2390		Electric push rod mount	06.P001	1
------	---	-------------------------	---------	---



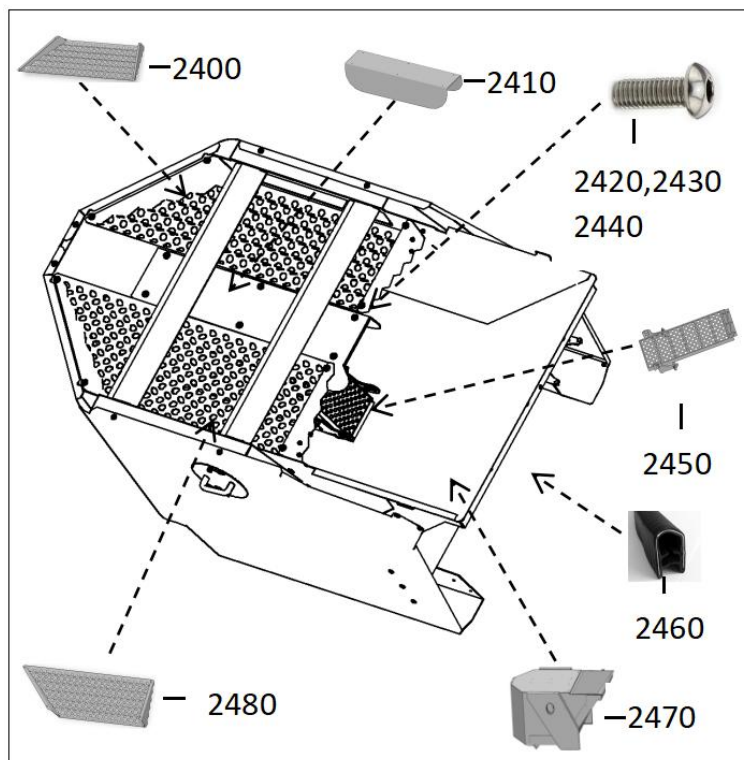
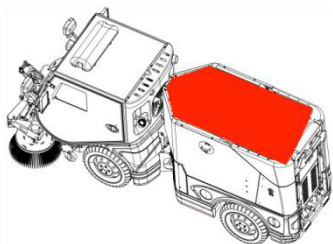

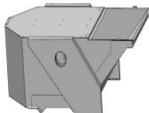

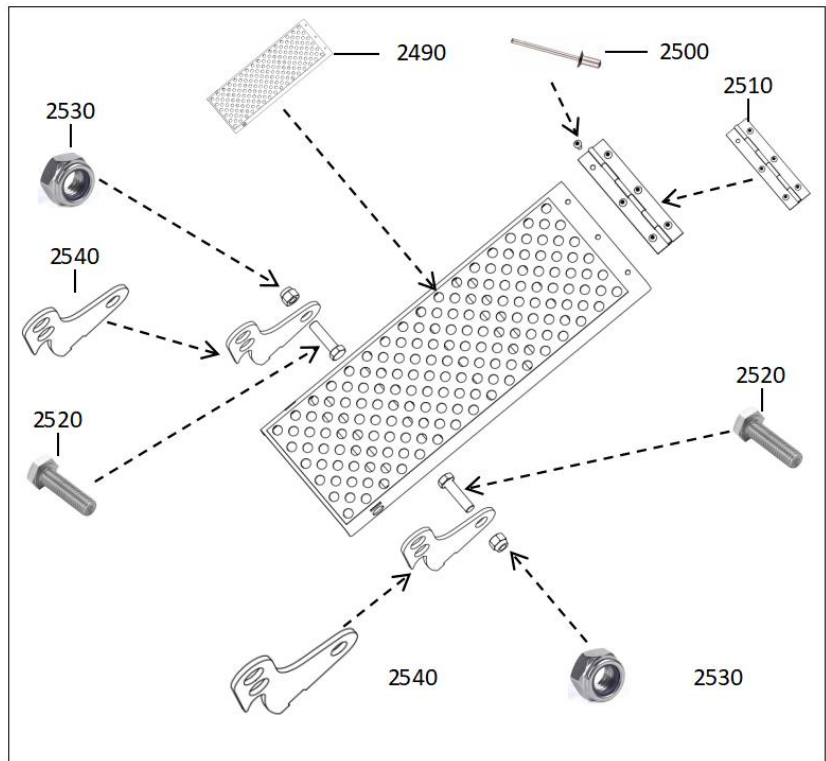
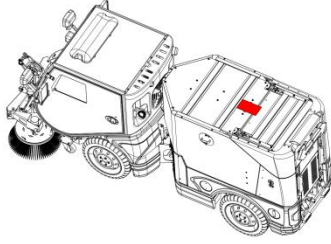

No.	Picture	Description	Material Code	Quantity
2400		Right filter	006.L002	1
2410		Baffle	006.L006	1
2420		Flat Round Head Inner Hexagon Screw	M6*20	18
2430		Flat washer	D6	18
2440		Spring washer	D6	18
2450		Sewage filter assembly	006.L003	1

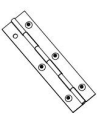

No.	Picture	Description	Material Code	Quantity
2460		Edge protector for sheet metal	B053	1
2470		Recycling bin body	006.L004	1
2480		Left filter	006.L005	1



No.	Picture	Description	Material Code	Quantity
2490		Sewage filter	RG · 3500 · 5 · 3 · 14	1
2500		Blind rivet	φ4	6
2510		Hinge	CL253-5	1
2520		Stainless steel outer hexagon screw	M6*45	2
2530		Stainless steel lock nut	M6	2
2540		Hopper lock hook	RG · 3500 · 5 · 12	2

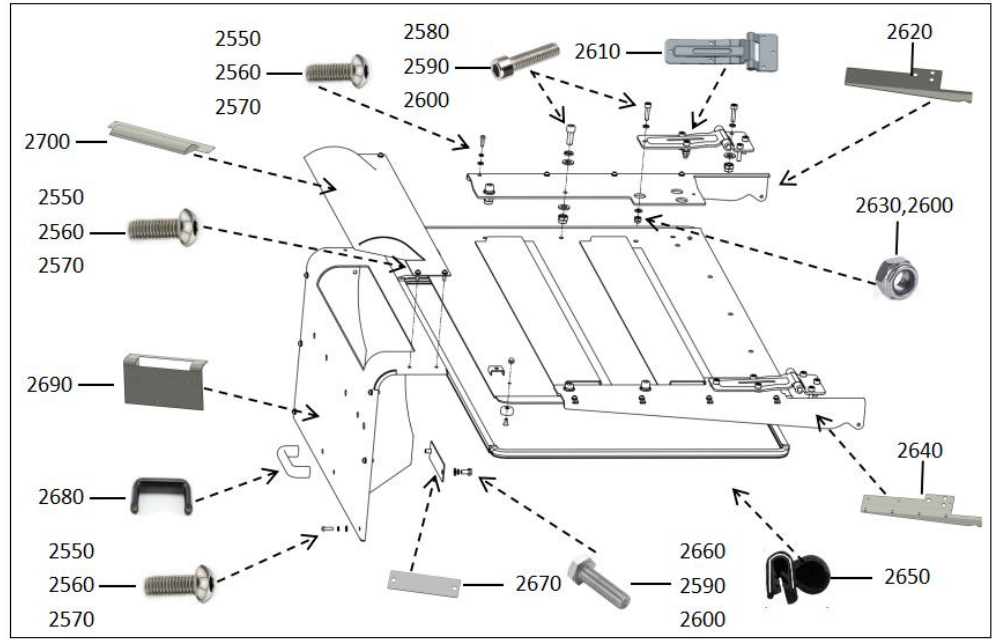
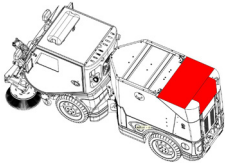

No.	Picture	Description	Material Code	Quantity
2550		Flat Round Head Inner Hexagon Screw	M6*20	18
2560		Spring washer	D6	18
2570		Washer	D6	18
2580		Socket cap head hexagon screw thread	M8*30	12
2590		Spring Washer	D8	12
2600		Washer	D8	12

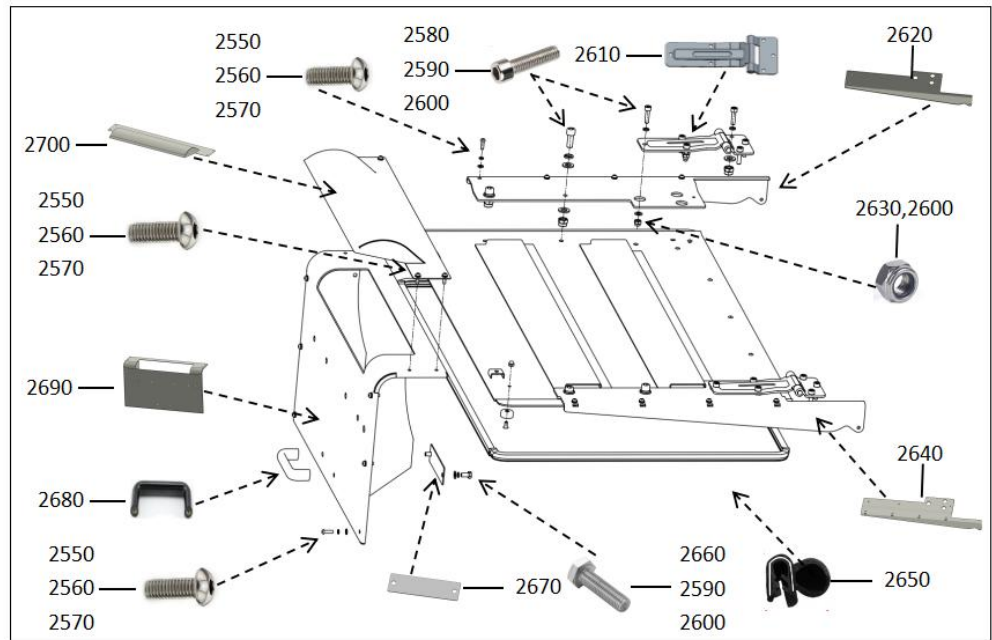
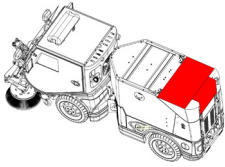

No.	Picture	Description	Material Code	Quantity
2610		Hopper hinge	CX-2317	2
2620		Left rear cover side panel	RG · 8240 · 5 · 4 · 1	1
2630		Nylon lock nut	M8	12
2640		Right rear cover side panel	RG · 8240 · 5 · 4 · 2	1
2650		Sealing strip for recycling bin lid	B052	3.4meters
2660		Outer hexagon full thread bolt	M8*16	2

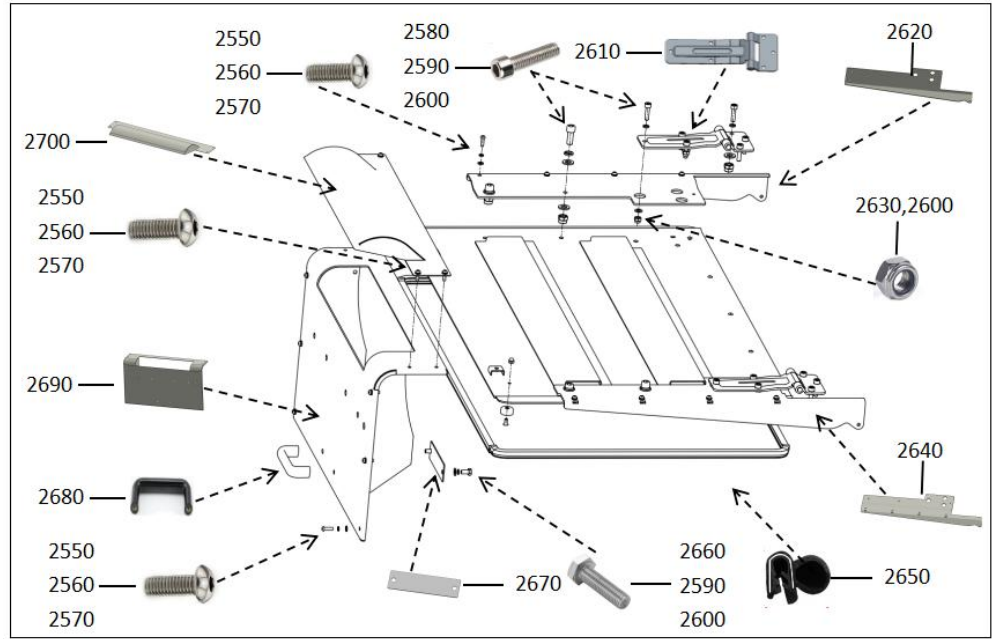
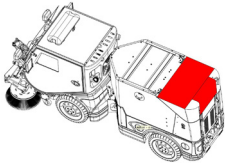



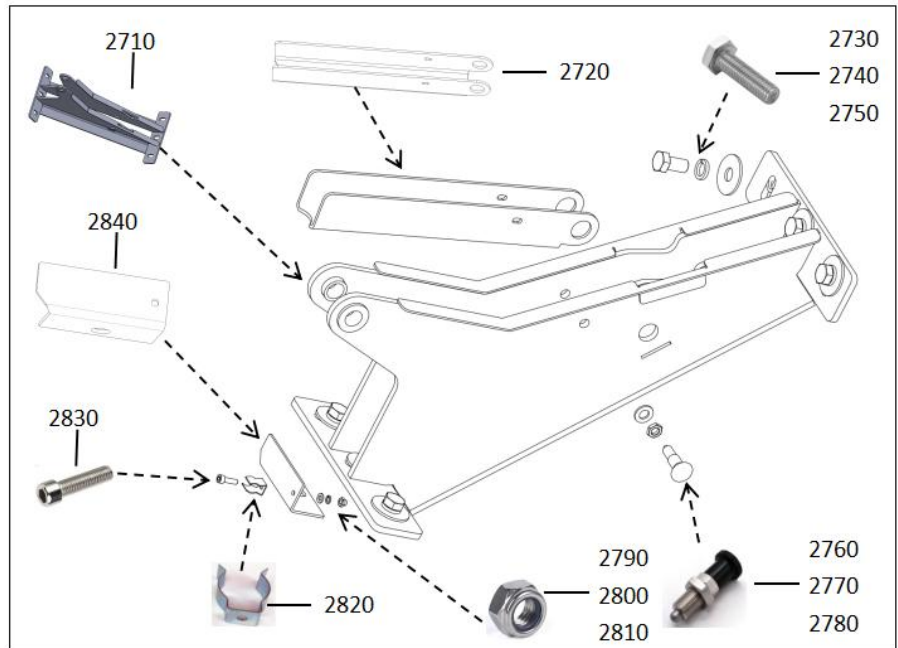
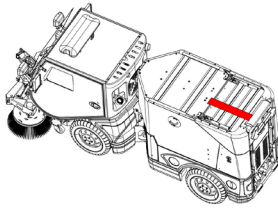

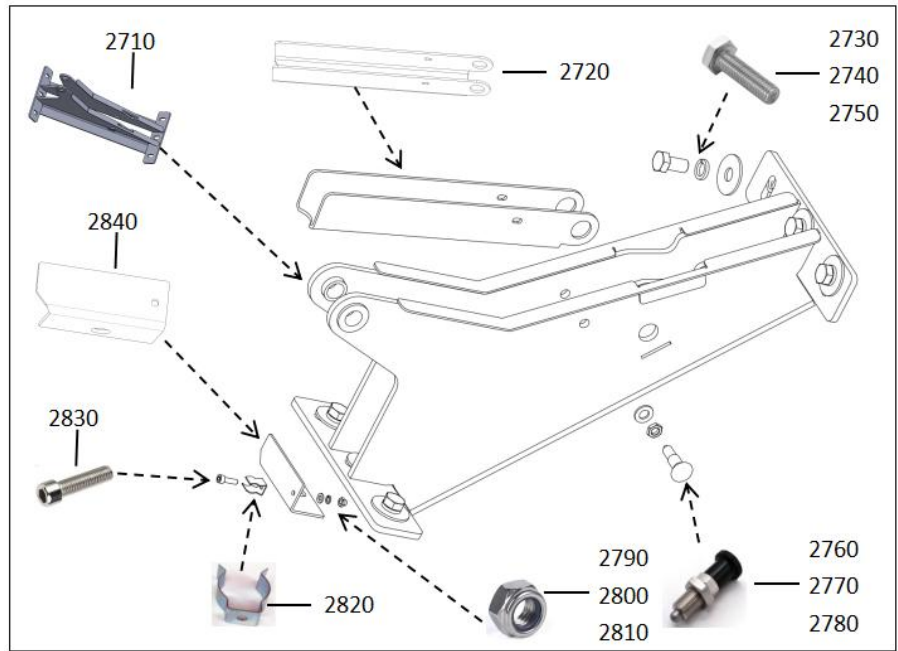
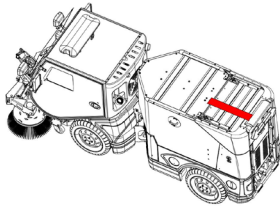

No.	Picture	Description	Material Code	Quantity
2670		Handle securing plate for rear cover door	RG · 3500 · 5 · 45	1
2680		Bakelite handle	B063	1
2690		Hopper - Door	RG · 3500 · 5 · 24	1
2700		Hopper door baffle	RG · 3500 · 5 · 57	1





No.	Picture	Description	Material Code	Quantity
2710		Welding of left support arm	RG · 3500 · 5 · 25-44	1
2720		Support arm - safe	RG · 3500 · 5 · 32	1
2730		Outer hexagon full thread bolt	M16*50	6
2740		Oversized washer	D16	6
2750		Spring washer	D16	6
2760		Index Pin	D275	1

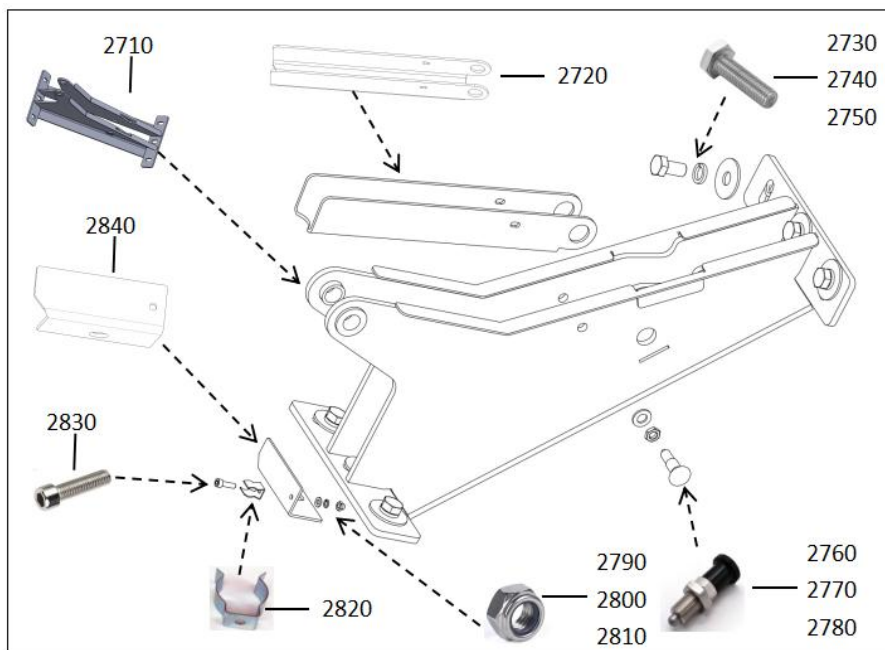
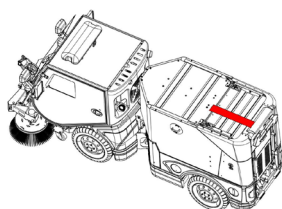

No.	Picture	Description	Material Code	Quantity
2770		Nut	M12	1
2780		Washer	D12	1
2790		Nylon lock nut	M6	1
2800		Washer	D6	1
2810		Spring Washer	D6	1
2820		Spring steel pipe clamp	Z110	1



No.	Picture	Description	Material Code	Quantity
2830		Hexagon socket head screw	M6*20	1
2840		L-shaped hook fixing plate A	RG · 3500 · 5 · 40	1

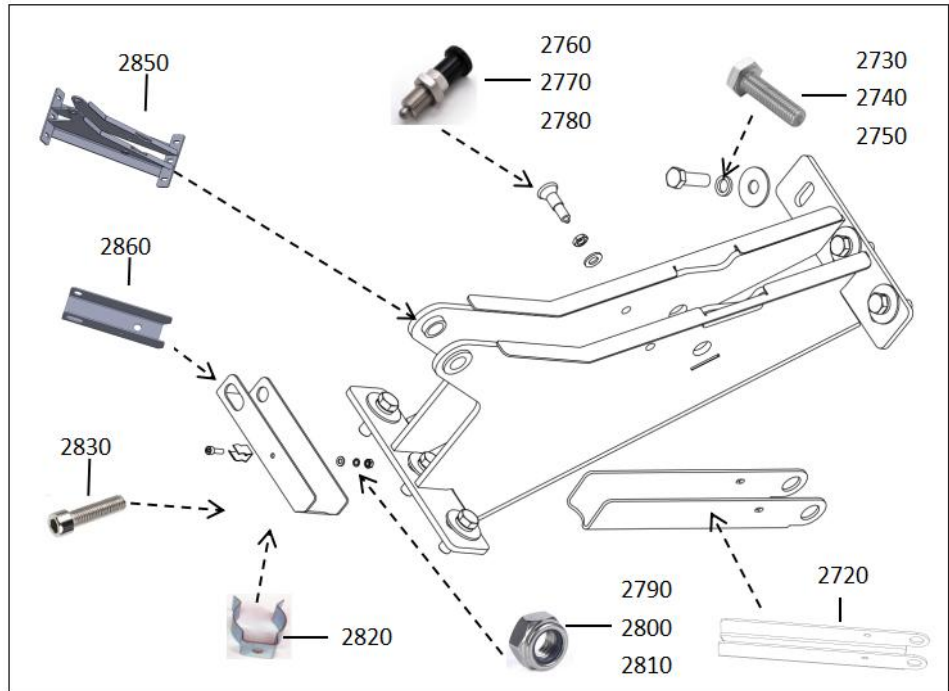
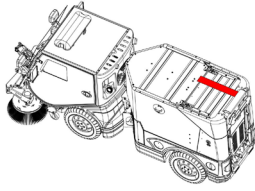

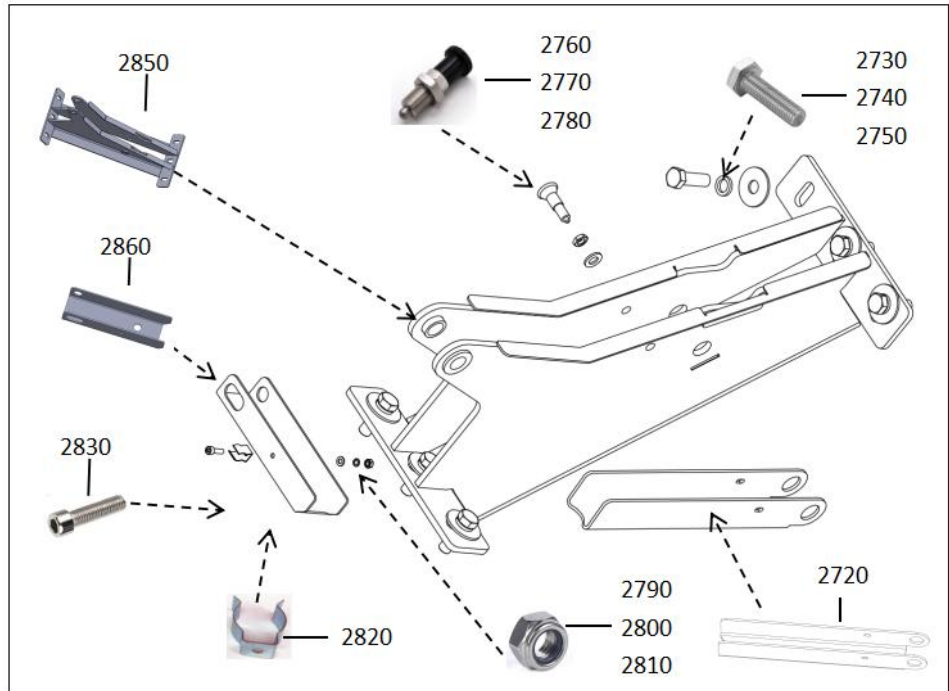
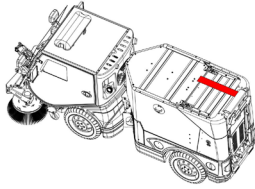

No.	Picture	Description	Material Code	Quantity
2850		Right support arm welded	RG · 3500 · 5 · 25-45	1
2720		Support arm - safe	RG · 3500 · 5 · 32	1
2730		Outer hexagon full thread bolt	M16*50	6
2740		Extended washer	D16	6
2750		Spring washer	D16	6
2760		Index pin	D275	1

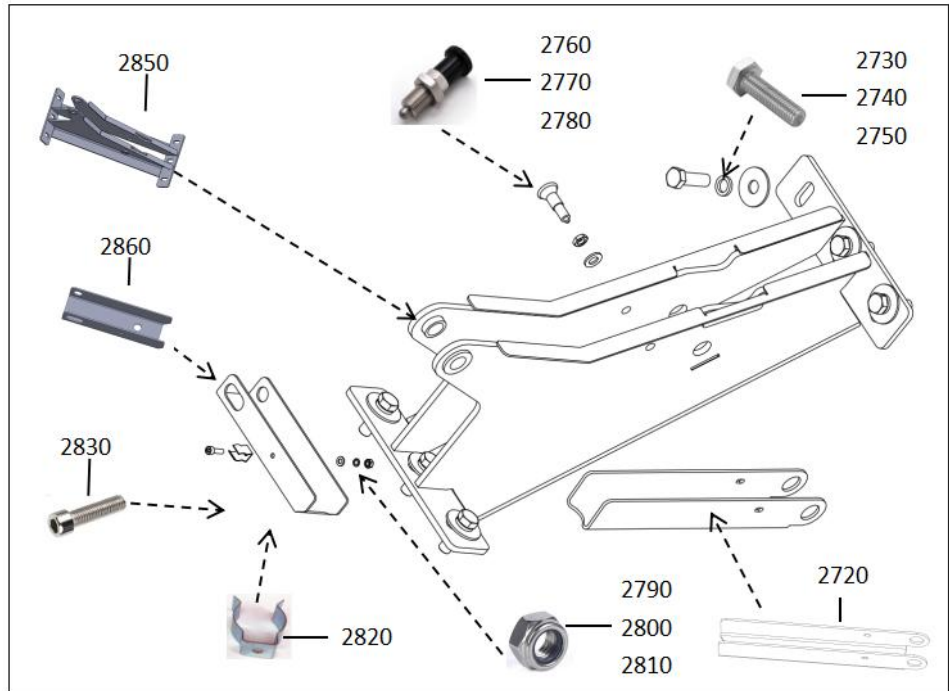
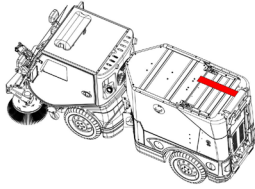

No.	Picture	Description	Material Code	Quantity
2770		Nut	M12	1
2780		Washer	D12	1
2790		Nylon lock nut	M6	1
2800		Washer	D6	1
2810		Spring washer	D6	1
2820		Elastic steel pipe clamp	Z110	1



No.	Picture	Description	Material Code	Quantity
2830		Hexagon socket head screw	M6*20	1
2860		M-shaped hook fixing plate A	RG · 3500 · 5 · 40	1

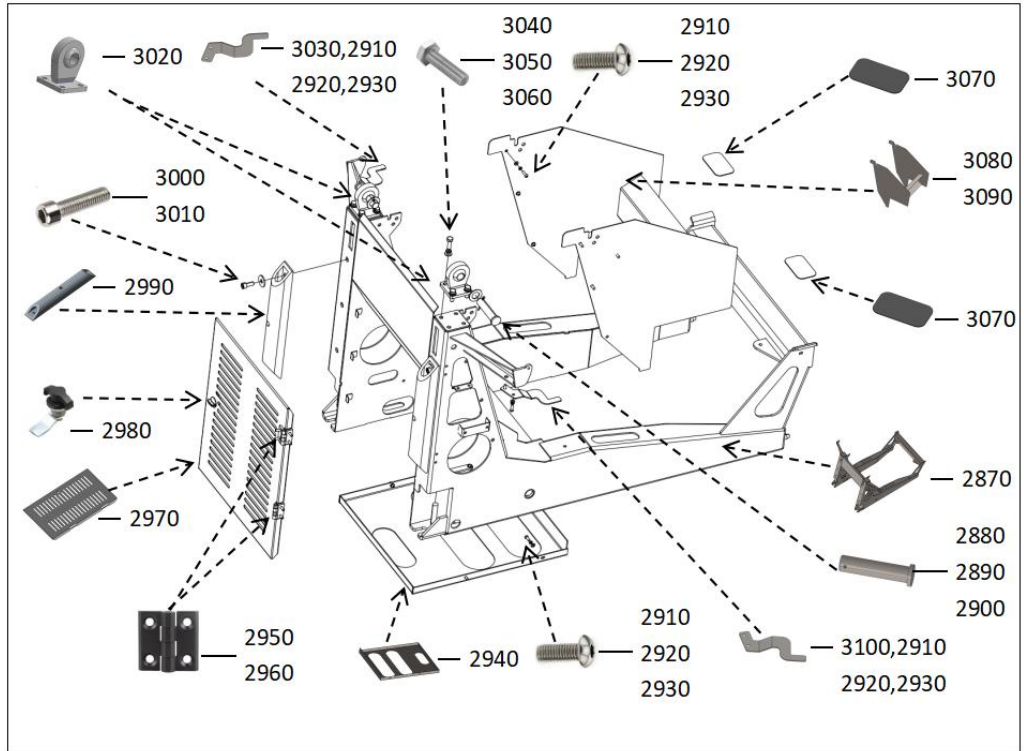
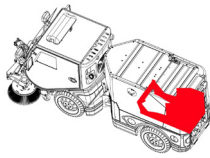

No.	Picture	Description	Material Code	Quantity
2870		Recycling bin body frame	RG · 3500 · 5 · 27	1
2880		Pin	RG · 3500 · 5 · 47	2
2890		Cotter Pin	φD4*35	2
2900		Washer	D22	2
2910		Flat Round Head Inner Hexagon Screw	M6*20	14
2920		Spring washer	D6	14

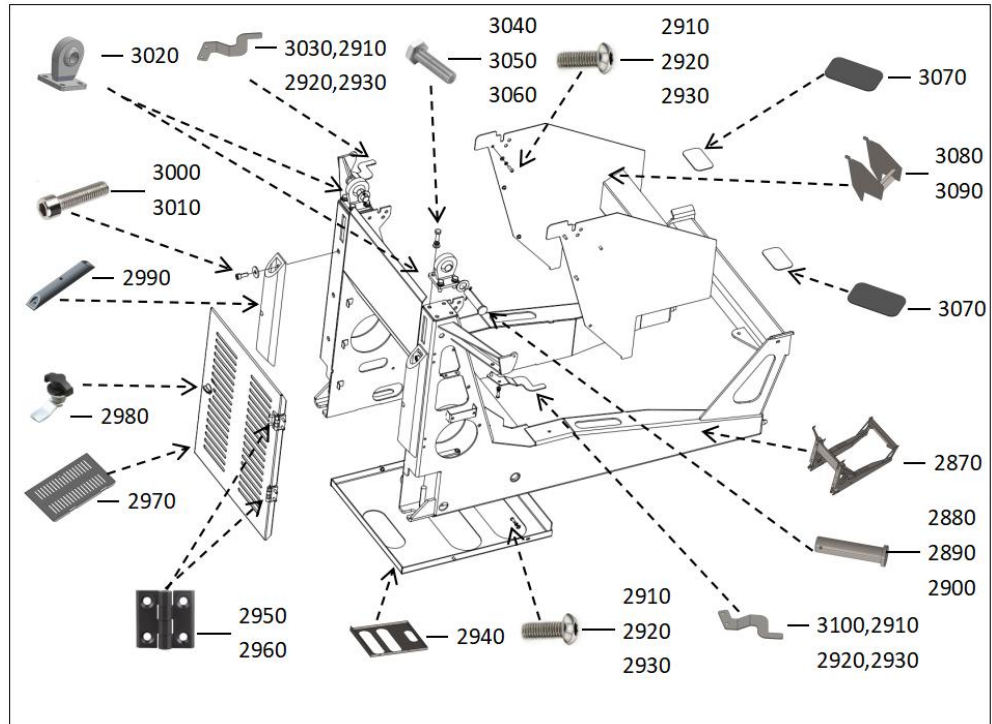
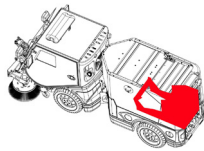

No.	Picture	Description	Material Code	Quantity
2930		Washer	D6	14
2940		Recycling bin- shelf	RG · 3500 · 5 · 37	1
2950		Hinge	50*50*6	2
2960		Hexagonal socket countersunk head cap head screw	M6*20	8
2970		Rear cover of the main bracket	RG · 3500 · 5 · 29	1
2980		Cam lock	B071	1

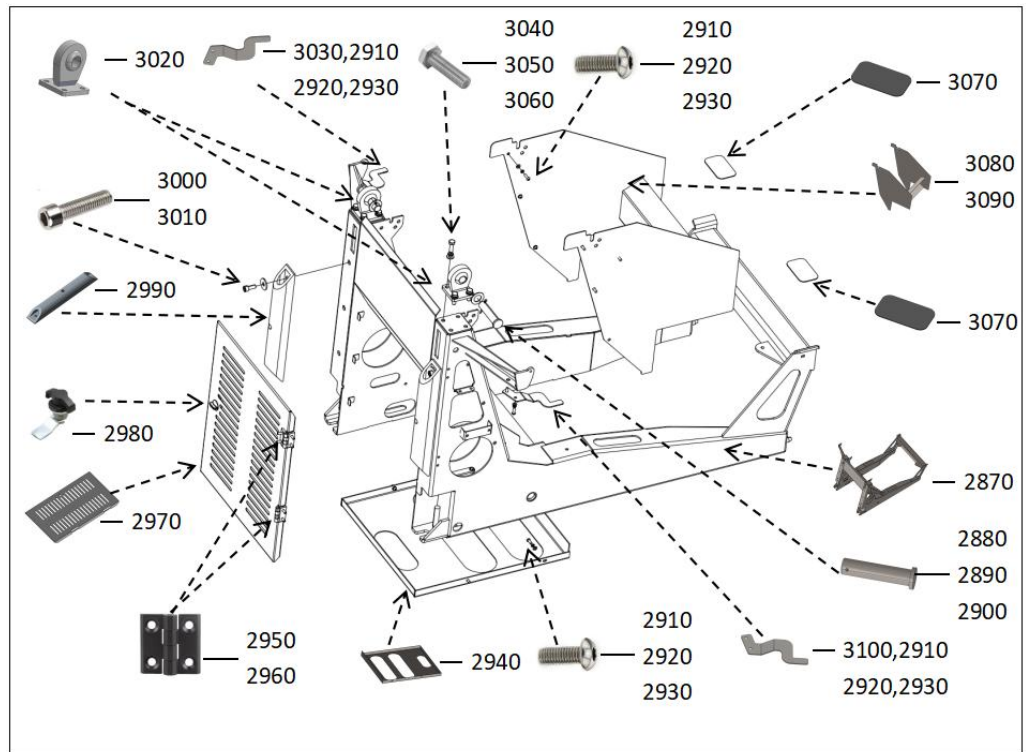
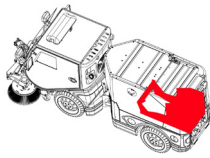





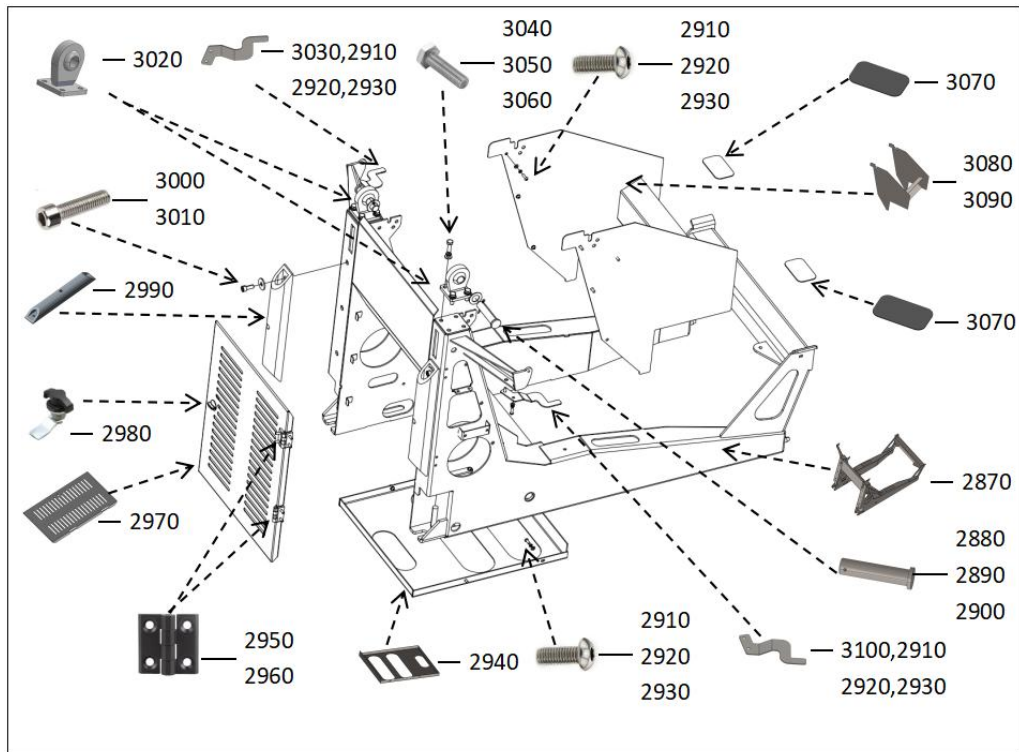
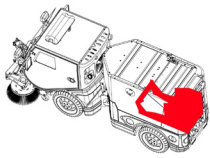

No.	Picture	Description	Material Code	Quantity
-----	---------	-------------	---------------	----------

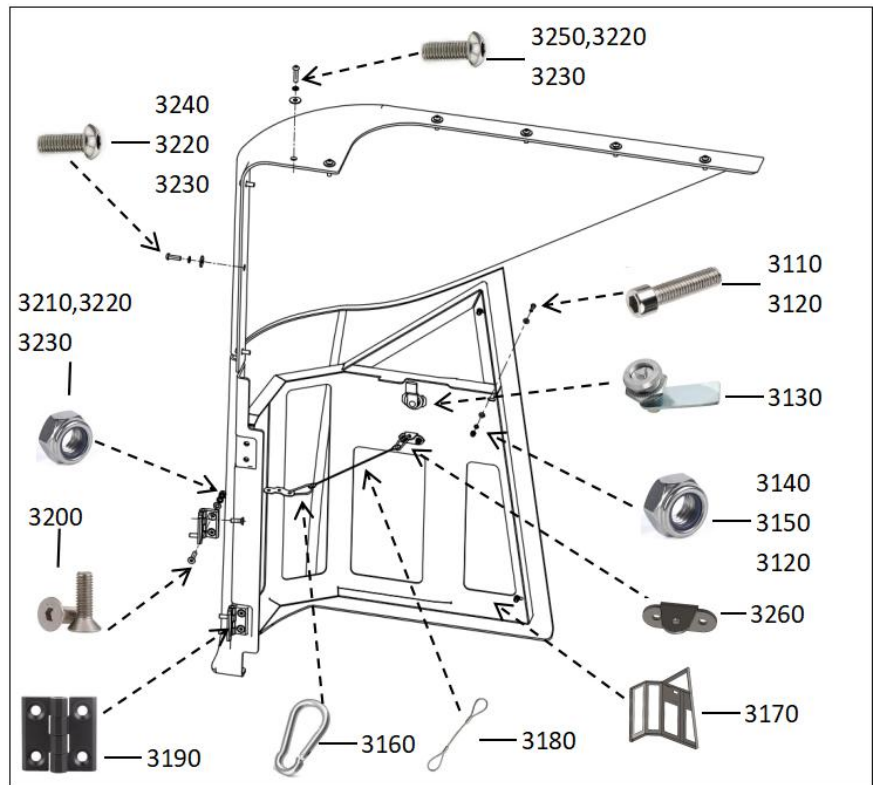
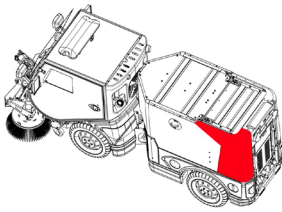
2990		Anti-collision strip	D 字形长 400mm	2
3000		Socket cap head hexagon screw thread	M10*65/GB70.1	6
3010		Oversized washer	D10	6
3020		Bearing block of recycling bin	RG · 3500 · 5 · 48	2
3030		Bracket of left rear lower cover	RG3500 · 5 · 52	1
3040		Outer hexagon bolt	M10*30/GB5783	8



No.	Picture	Description	Material Code	Quantity
3050		Spring washer	D10	8
3060		Washer	D10	8
3070		Rubber pad	006.L007	2
3080		Recycling bin - air outlet baffle	RG · 3500 · 5 · 56	1
3090		Edge protection of air outlet	B053	2.8meters
3100		Bracket of right rear lower cover	RG3500 · 5 · 53	1



No.	Picture	Description	Material Code	Quantity
3110		Flat Round Head Inner Hexagon Screw	M4*12	6
3120		Oversized washer	D4	12
3130		Locking button	B071	1
3140		Nylon lock nut	M4	6
3150		Spring washer	D4	6
3160		Cord fastener	006.L007-1	2

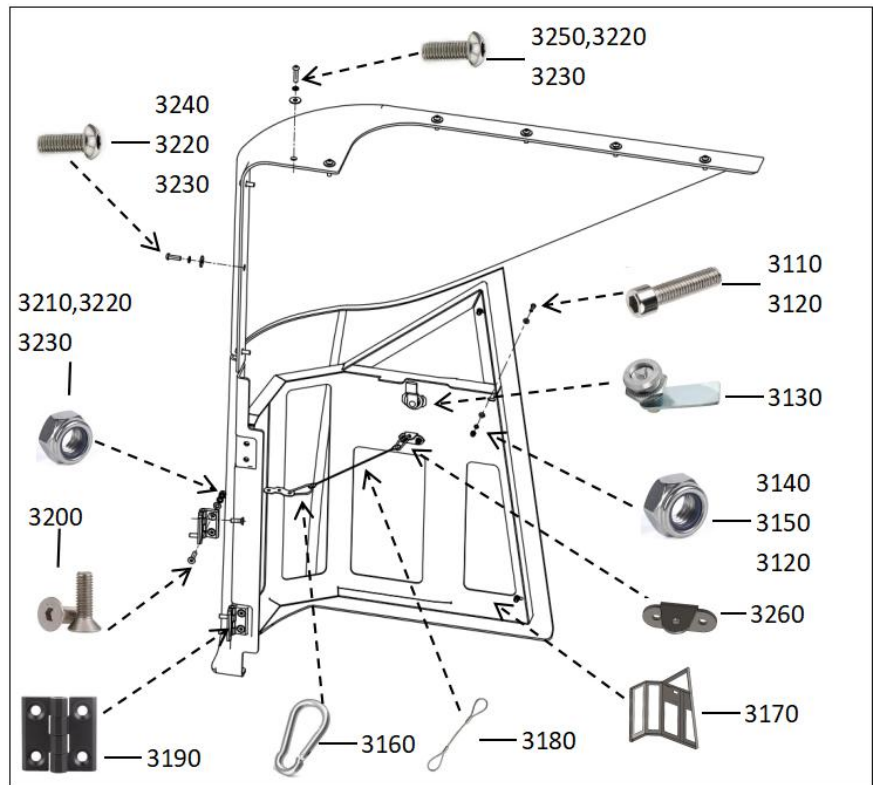
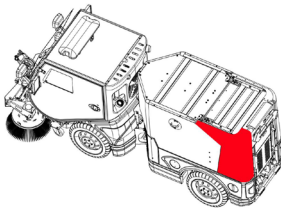



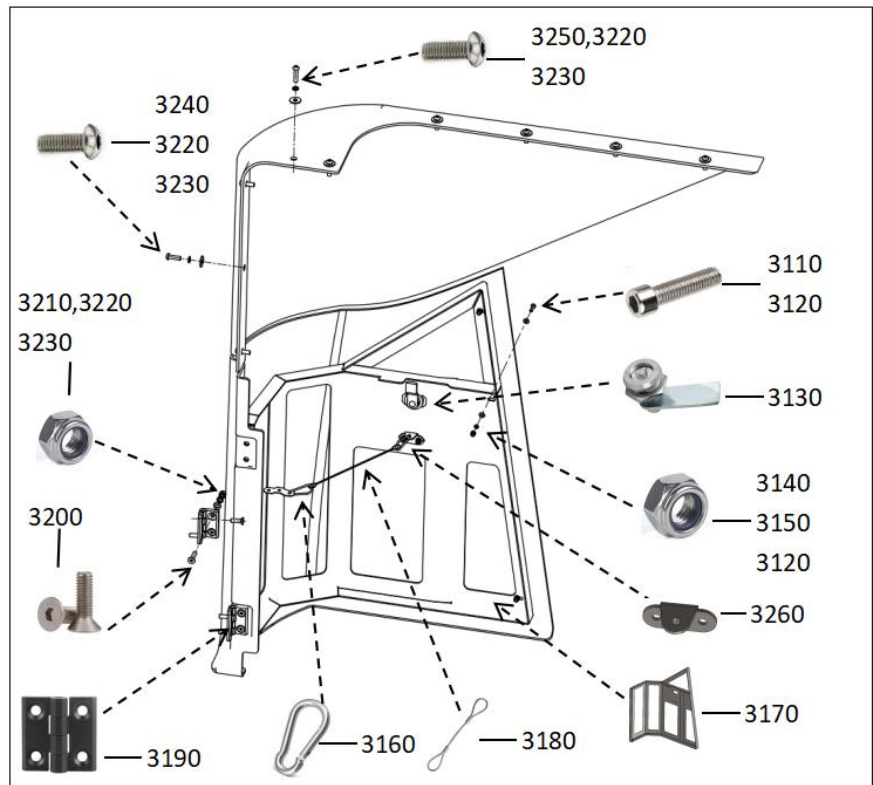
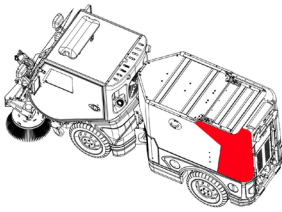

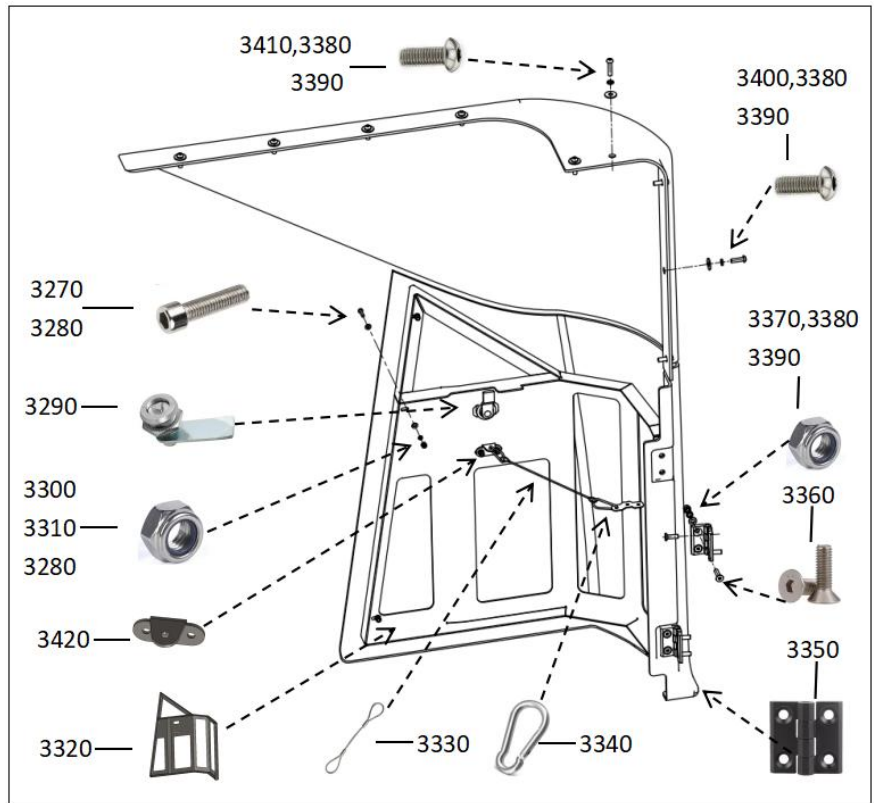
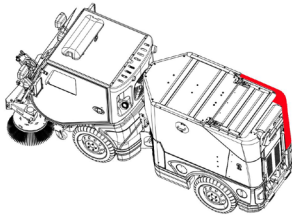

No.	Picture	Description	Material Code	Quantity
3170		Left door lining of recycling bin	RG3500 · 5 · 54.1	1
3180		Steel wire rope	006.L007-2	1
3190		Hinge	B072	2
3200		Hexagonal socket countersunk head cap head screw	M6*20	8
3210		Nylon lock nut	M6	4
3220		Spring washer	D6	13



No.	Picture	Description	Material Code	Quantity
3330		Oversized washer	D6	13
3240		Flat Round Head Inner Hexagon Screw	M6*20	7
3250		Flat Round Head Inner Hexagon Screw	M6*25	2
3260		Inside bar	RG · 3500 · 5 · 42	1





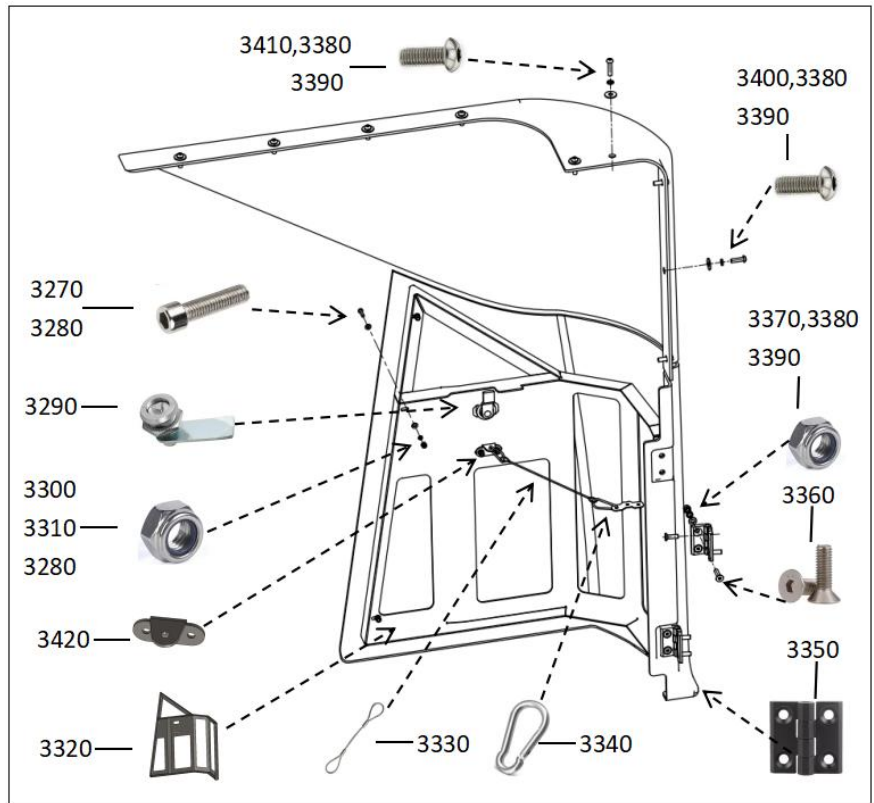
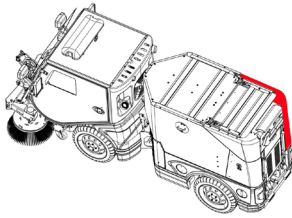

No.	Picture	Description	Material Code	Quantity
3270		Flat Round Head Inner Hexagon Screw	M4*12	6
3280		Oversized washer	D4	12
3290		Locking button	B071	1
3300		Nylon lock nut	M4	6
3310		Spring washer	D4	6
3320		Cord fastener	006.L007-1	2

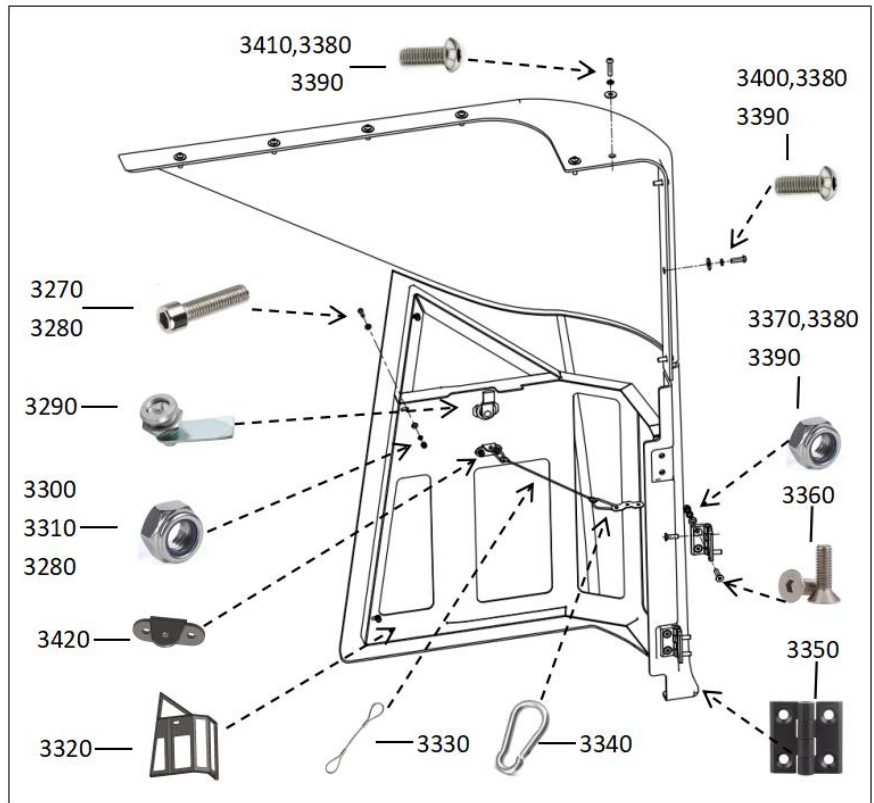
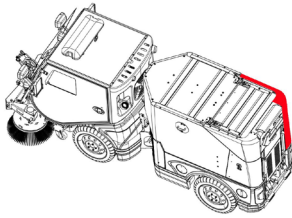

No.	Picture	Description	Material Code	Quantity
3330		Right door lining of recycling bin	RG3500 · 5 · 54.2	1
3340		Steel wire rope	006.L007-2	1
3350		Hinge	B072	2
3360		Hexagonal socket countersunk head cap head screw	M6*20	8
3370		Nylon lock nut	M6	4
3380		Spring washer	D6	13





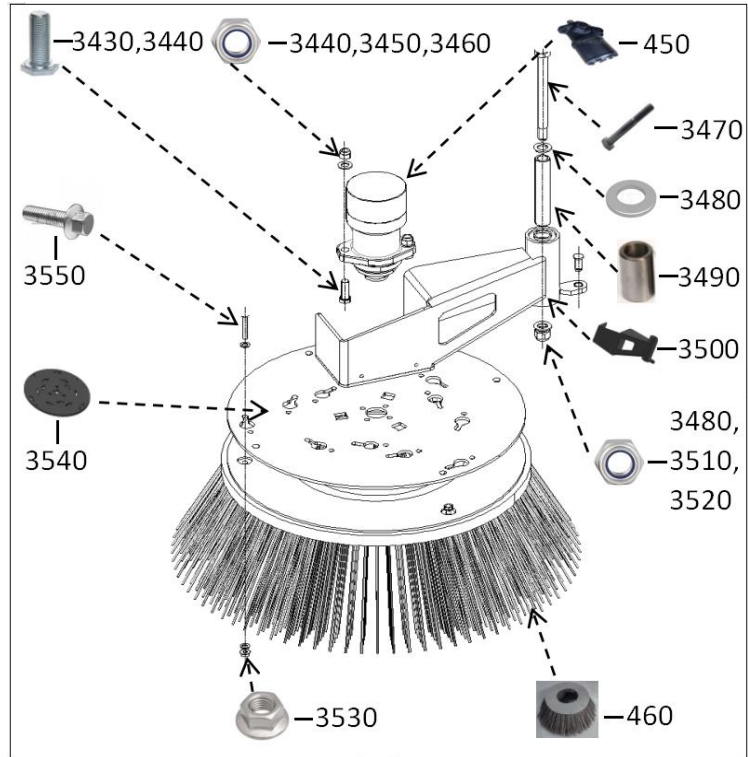
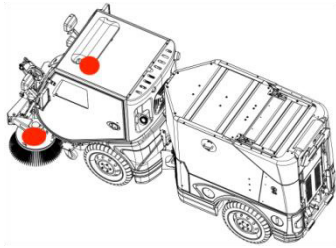

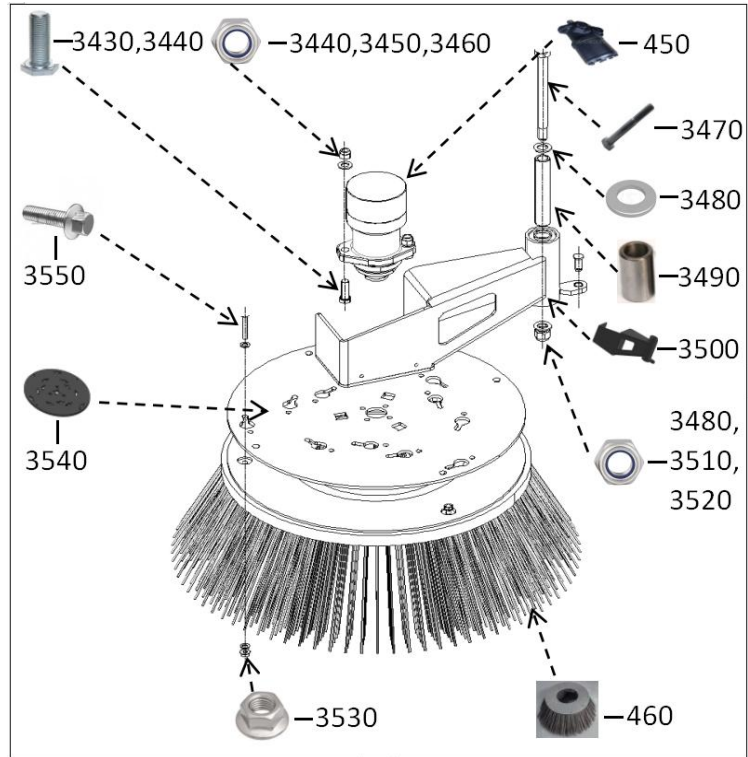
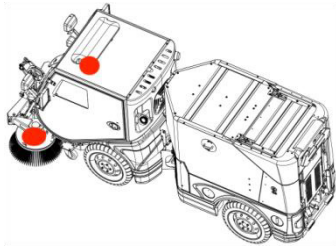

No.	Picture	Description	Material Code	Quantity
3390		Oversized washer	D6	13
3400		Flat Round Head Inner Hexagon Screw	M6*20	7
3410		Flat Round Head Inner Hexagon Screw	M6*25	2
3420		Inside bar	RG · 3500 · 5 · 42	1



No.	Picture	Description	Material Code	Quantity
3430		Outer hexagon full thread bolt	M12*45	4
3440		Flat washer	D12	4
3450		Nylon lock nut	M12	4
3460		Spring washer	D12	4
3470		Outer hexagon half-thread bolt	M16*195	2
3480		Flat washer	D16	4

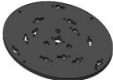

No.	Picture	Description	Material Code	Quantity
3490		Brush liner	RG · 3500 · 7 · 24	2
3500		Support bracket for swing arm	RG · 8240 · 7 · 2	2
3510		Nylon locking nut	M16	2
3520		Spring washer	D16	2
3530		Flange nut	M8	6
3540		Fixed piece of brush disk	RG · 8240 · 7 · 10	2
3550		Flange nut	M8	6

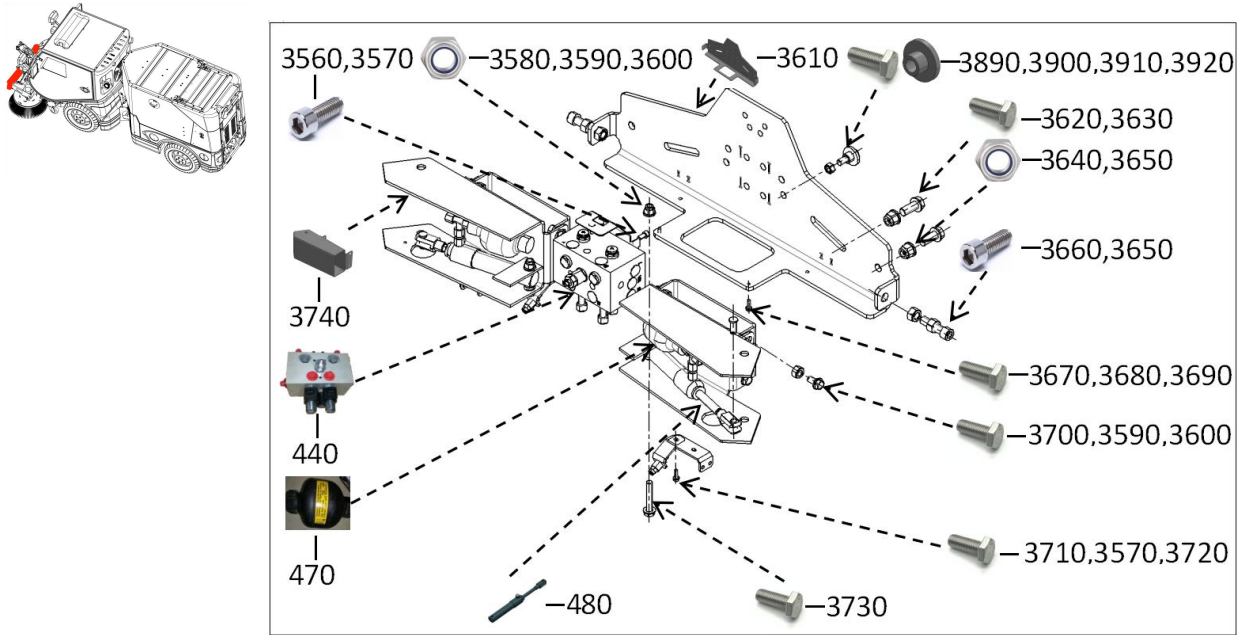

No.	Picture	Description	Material Code	Quantity
3560		Internal hexagonal socket head full thread bolt	M8*20	2
3570		Spring washer	D8	4
3580		Nylon locking nut	M12	2
3590		Spring washer	D12	6
3600		Flat washer	D12	6
3610		Front brush connecting plate component	RG · 8240 · 7 · 4	1

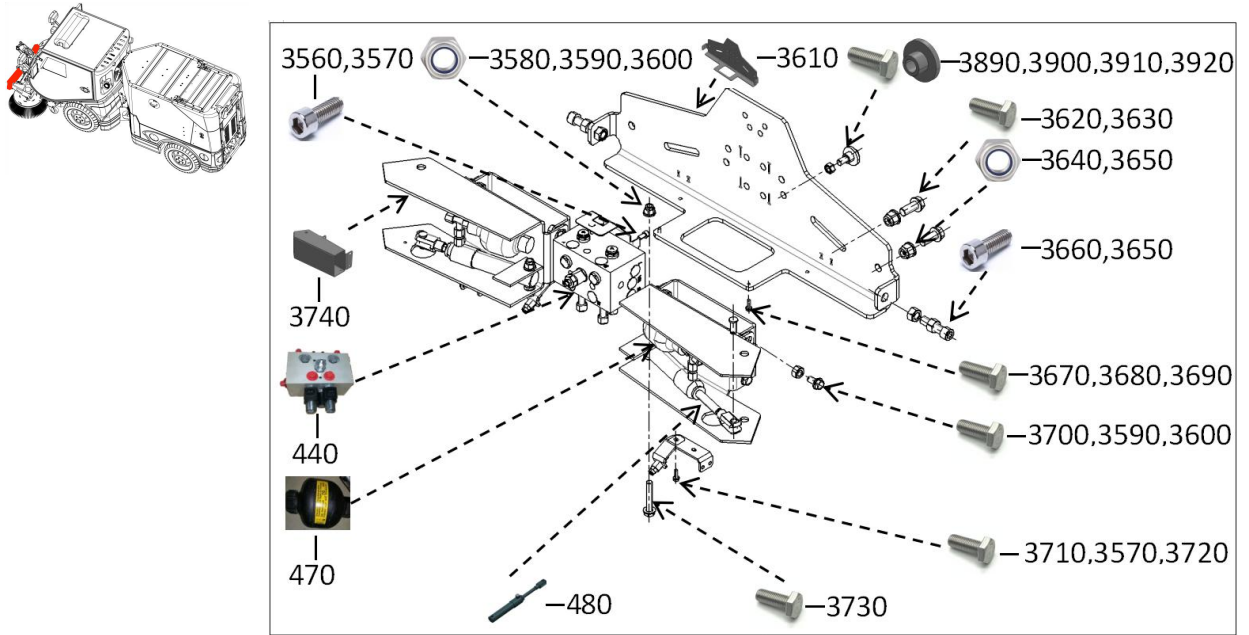

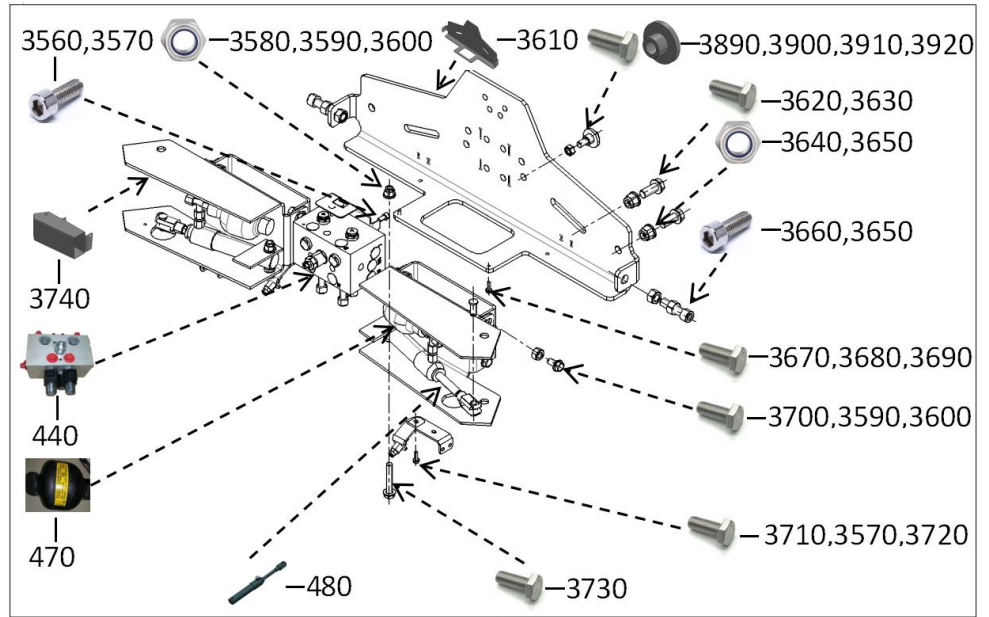
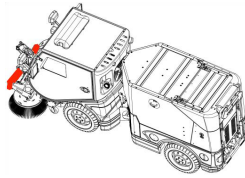

No.	Picture	Description	Material Code	Quantity
3620		Outer hexagon full thread bolt	M16*45	4
3630		Spring washer	D16	4
3640		Flat washer	D16	4
3650		Nylon locking nut	M16	6
3660		Internal hexagonal socket head full thread bolt	M16*75	2
3670		Outer hexagon full thread bolt	M6*16	2



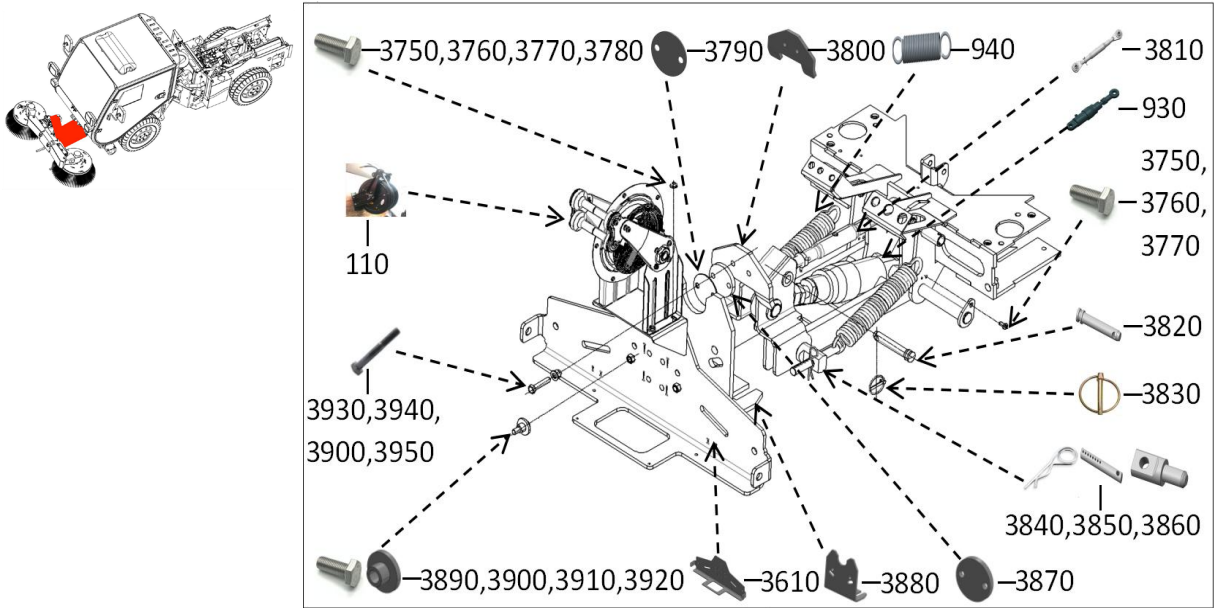



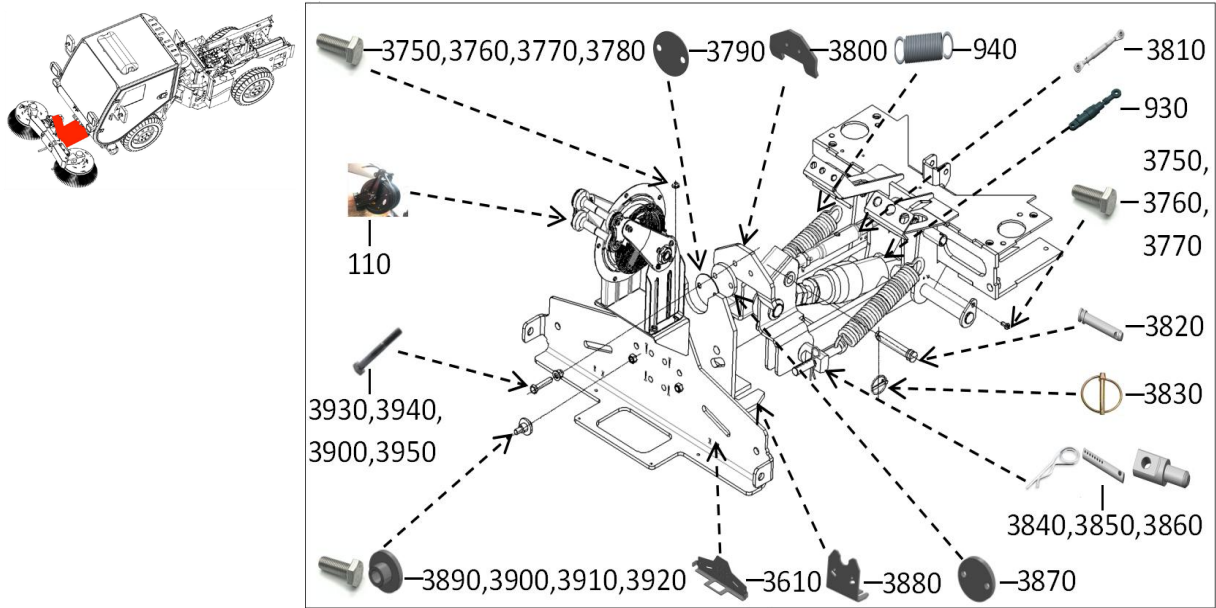

No.	Picture	Description	Material Code	Quantity
3680		Spring washer	D6	2
3690		Oversized flat washer	D6	2
3700		Outer hexagon full thread bolt	M12*30	4
3710		Outer hexagon full thread bolt	M8*20	2
3720		Flat washer	D8	2
3730		Outer hexagon full thread bolt	M12*75	2
3740		Bracket of swing arm	RG · 8240 · 7 · 2	2



No.	Picture	Description	Material Code	Quantity
3750		Outer hexagon full thread bolt	M8*20	4
3760		Flat washer	D8	4
3770		Spring washer	D8	4
3780		Nylon locking nut	M8	4
3790		Front brush clamping thin partition	RG · 8240 · 7 · 7	1
3800		Front brush clamping plate	RG · 8240 · 7 · 6	1



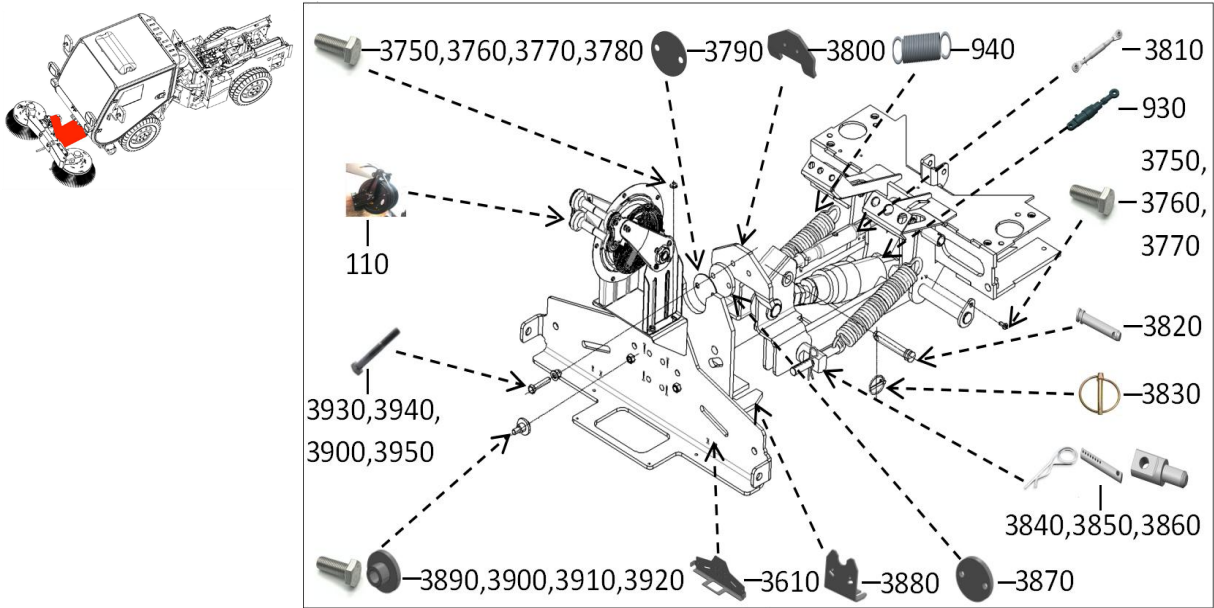

No.	Picture	Description	Material Code	Quantity
3810		Front linkage	A022-03	1
3820		Hole pin	A006-06	1
3830		O-shaped safety pin	D121	1
3840		Double wire R-clip pin	D122	2
3850		Multi-hole pin	A006-10	2
3860		Spring tension pin	A006-09	2



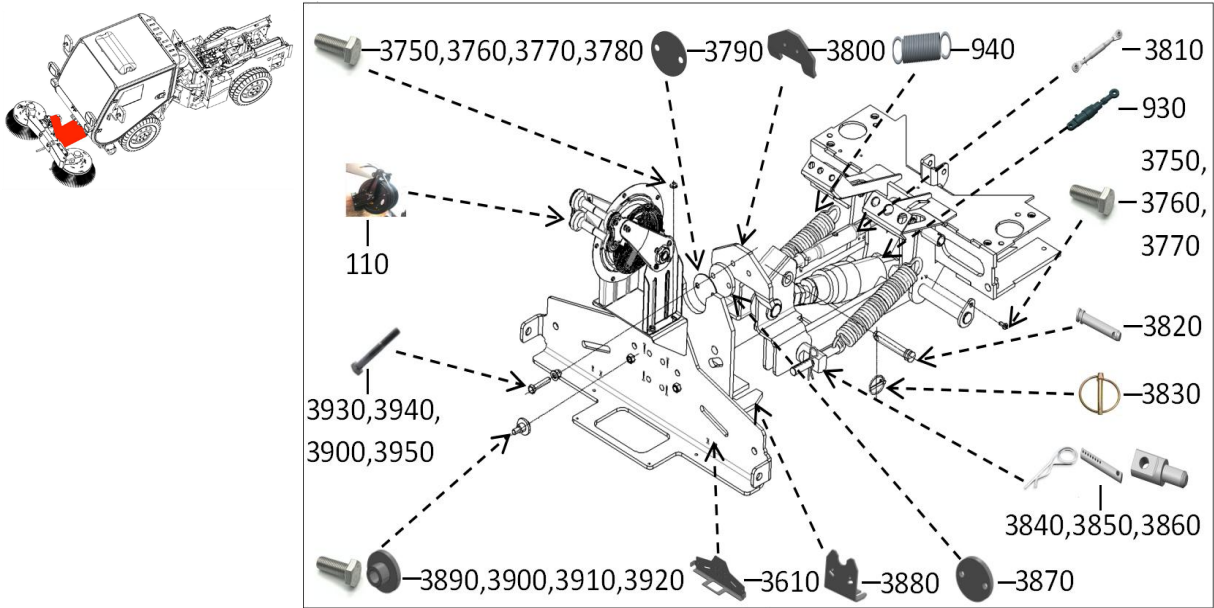



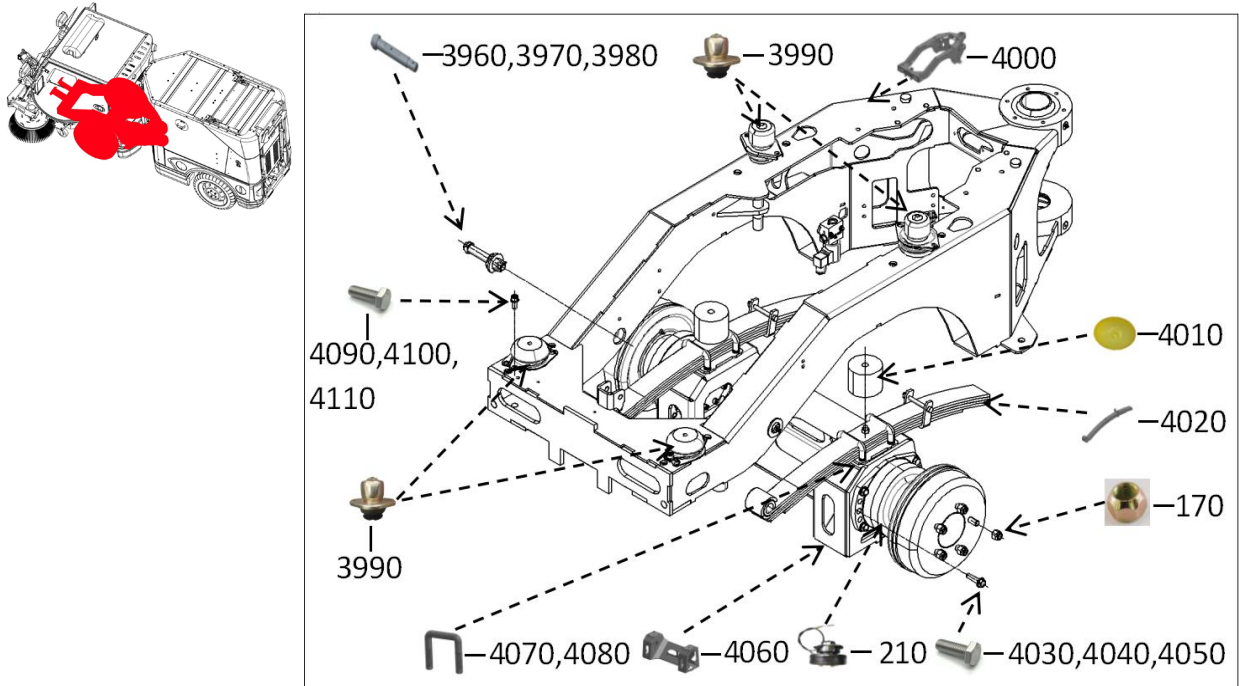

No.	Picture	Description	Material Code	Quantity
3870		Front brush clamping thick partition	RG · 8240 · 7 · 8	1
3880		Front brush hanging board 1	RG · 3500 · 3 · 5 · 1	1
3890		Outer hexagon full thread bolt	M12*30	2
3900		Spring washer	D12	4
3910		Flat washer	D12	2
3920		Hanging plate pin sleeve	RG · 3500 · 3 · 5 · 5	2



No.	Picture	Description	Material Code	Quantity
3930		Outer hexagon half-thread bolt	M12*35	2
3940		Oversized flat washer	D12	2
3950		Nylon locking nut	M12	2



No.	Picture	Description	Material Code	Quantity
3960		Slotted nut	M18	2
3970		Cotter pin $\varnothing D4 \times 35$	D616	2
3980		Leaf spring pin	A007-03	2
3990		Cab shock absorption	B083-01	4
4000		Front frame	RG · 8240 · 3 · 11	1
4010		Spring steel rubber pad	A065-01/02	2

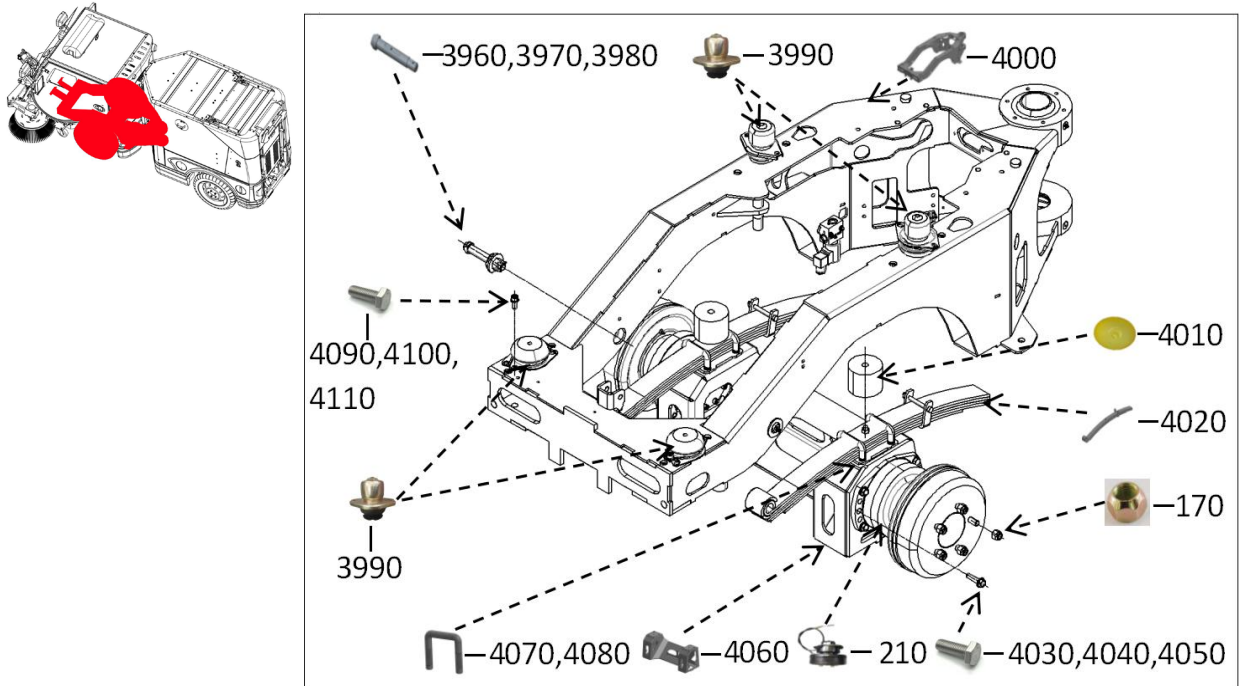

No.	Picture	Description	Material Code	Quantity
4020		Spring steel plate assembly	A035	2
4030		Hexagonal head full thread bolt	M12*45	12
4040		Spring washer	D12	12
4050		Flat washer	D12	12
4060		Fixed base of front walking motor	RG · 8240 · 3 · 13	1
4070		Leaf spring fixing parts	A034	4

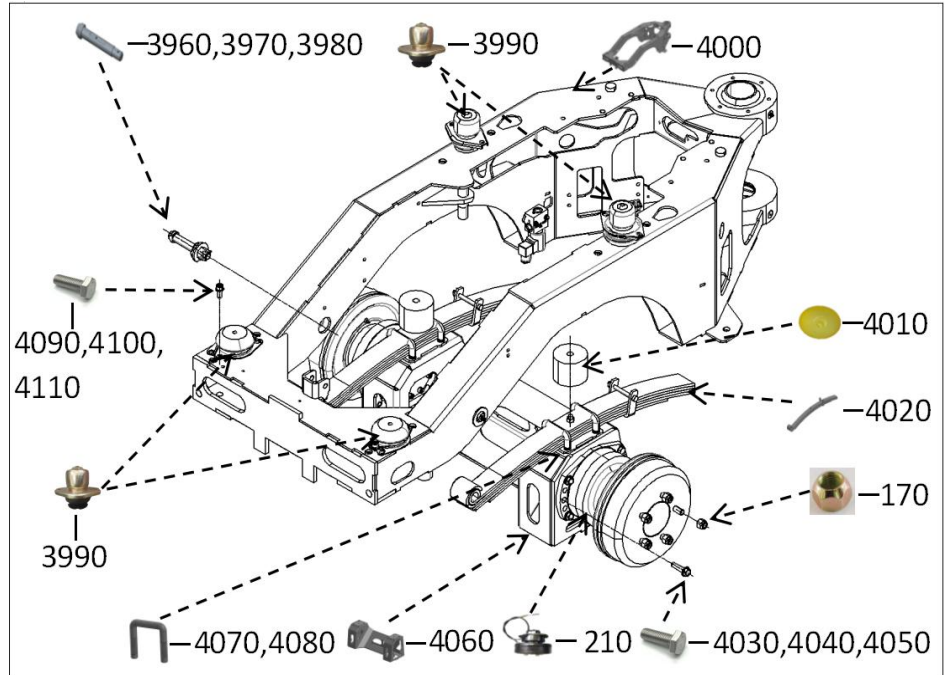
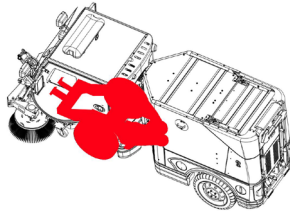

No.	Picture	Description	Material Code	Quantity
4080		Nylon locking nut	M16	8
4090		Hexagonal head full thread bolt	M10*25	4
4100		Spring washer	D10	4
4110		Flat washer	D10	4

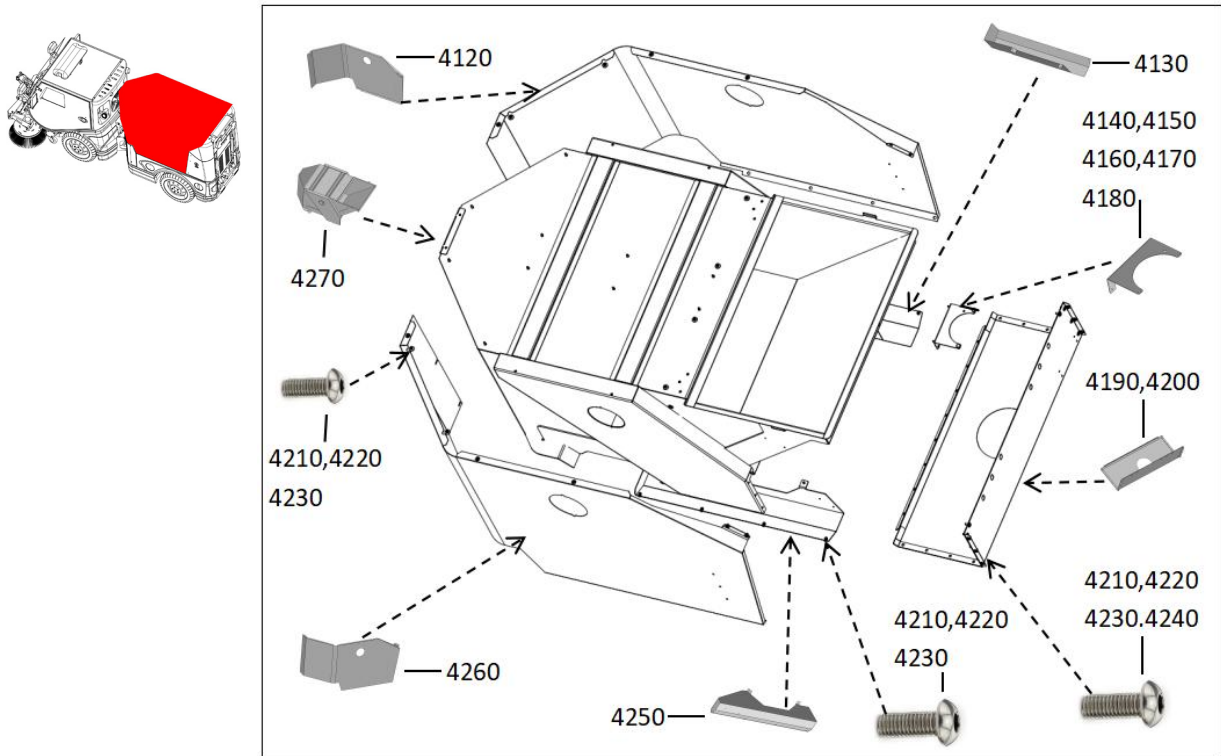

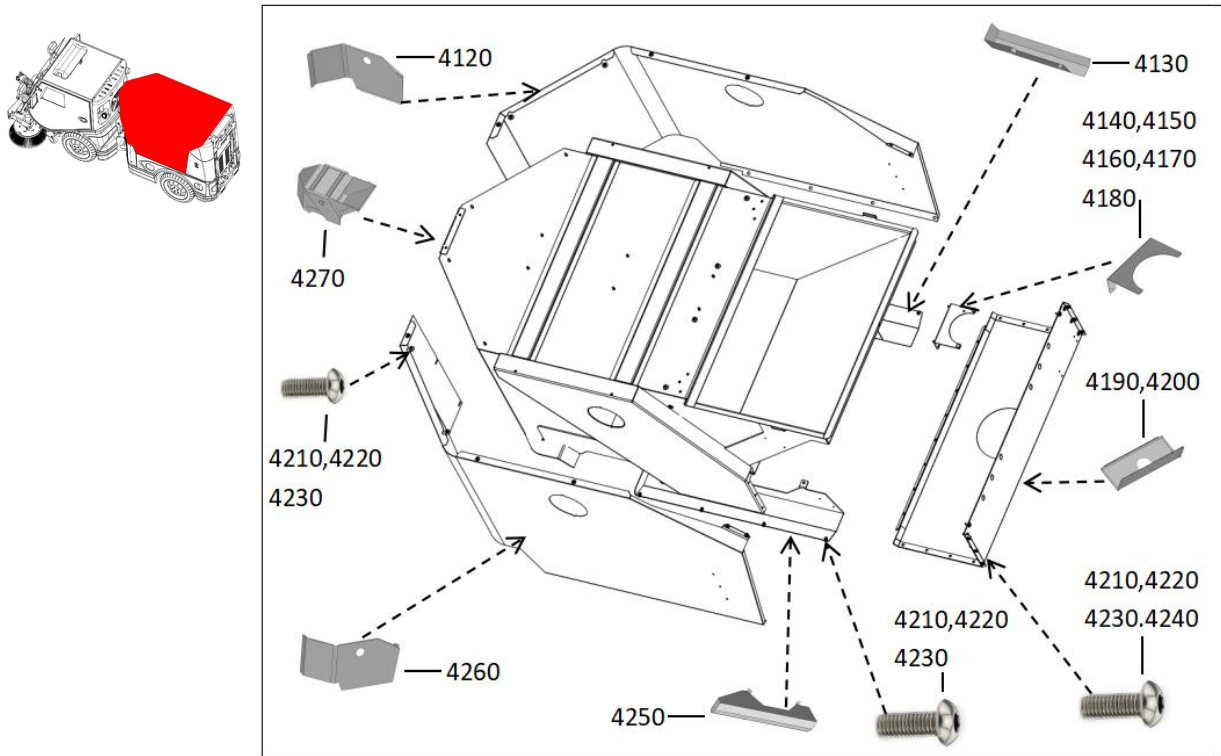

No.	Picture	Description	Material Code	Quantity
4120		Right shell	RG · 3500 · 5 · 2	1
4130		Fixed base of flexible hose	RG · 8240 · 5 · 13	1
4140		Fixed base of flexible hose nozzle	RG · 3500 · 5 · 15	1
4150		Knurled bolt	M5*10 不锈钢	2
4160		Hexagonal socket head screw	M4*12	4
4170		Washer	D4	4



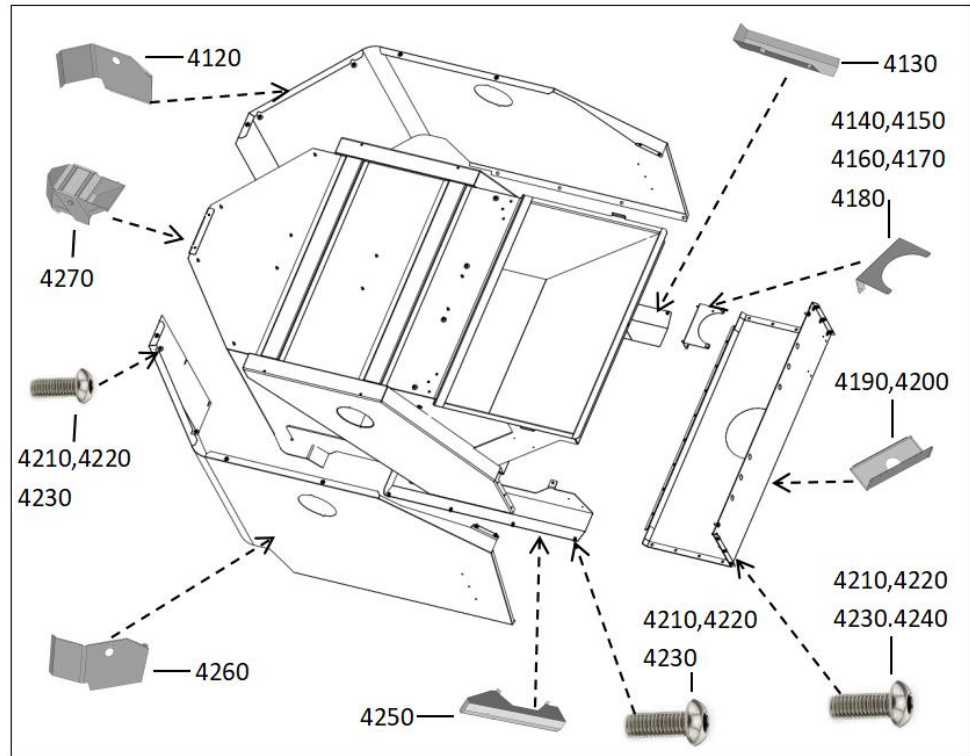
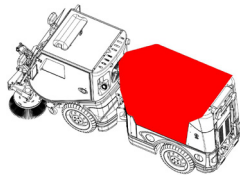

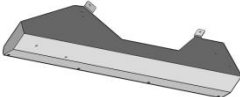
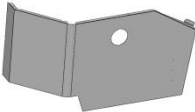
No.	Picture	Description	Material Code	Quantity
4180		Spring washer	D4	4
4190		Vacuum cover plate	RG · 8240 · 5 · 14	1
4200		Edge protection of sheet metal	B054	0.42
4210		Flat Round Head Inner Hexagon Screw	M6*20	78
4220		Washer	D6	84
4230		Spring washer	D6	78

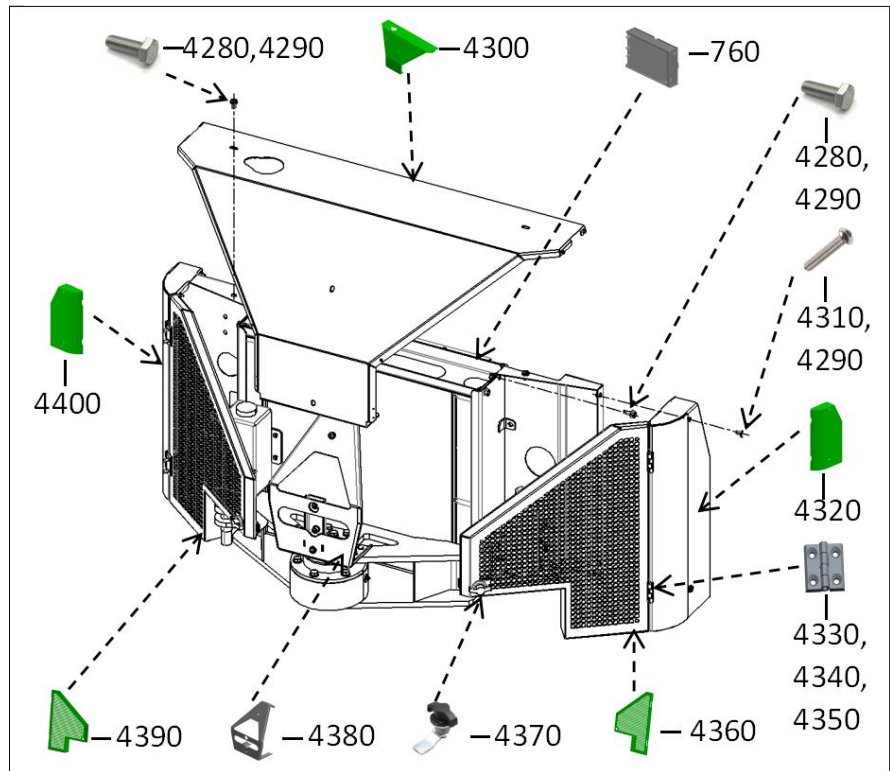
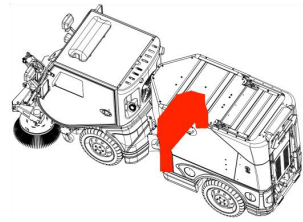

No.	Picture	Description	Material Code	Quantity
4240		Nylon locking nut	M6	6
4250		Fixed base of high-pressure water gun	RG · 8240 · 5 · 12	1
4260		Left shell	RG · 3500 · 5 · 1	1
4270		Welding body of recycling bin	RG · 3500 · 5 · 3	1



No.	Picture	Description	Material Code	Quantity
4280		Hexagonal head full thread bolt	M8*20	6
4290		Flat washer	D8	6
4300		Outer middle protective plate of water tank	RG8240 · 4 · 15	1
4310		Flat Round Head Inner Hexagon Screw	M8*20	6
4320		Left outer small protective plate of water tank	RG8240 · 4 · 18.1	1
4330		Hinge	B072	4

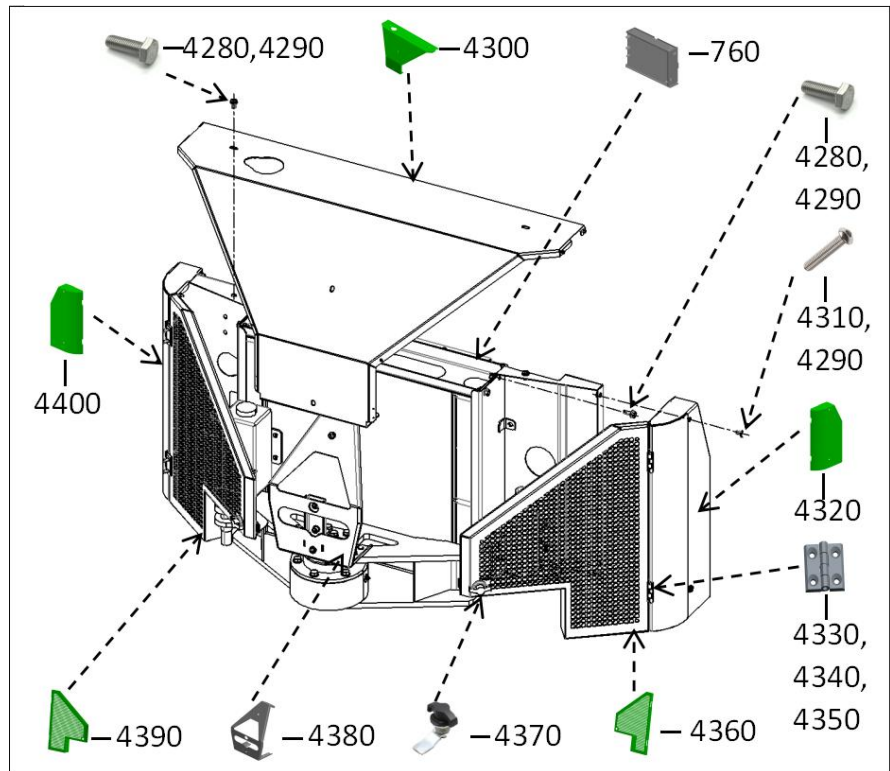
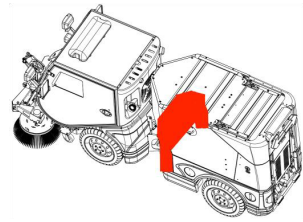

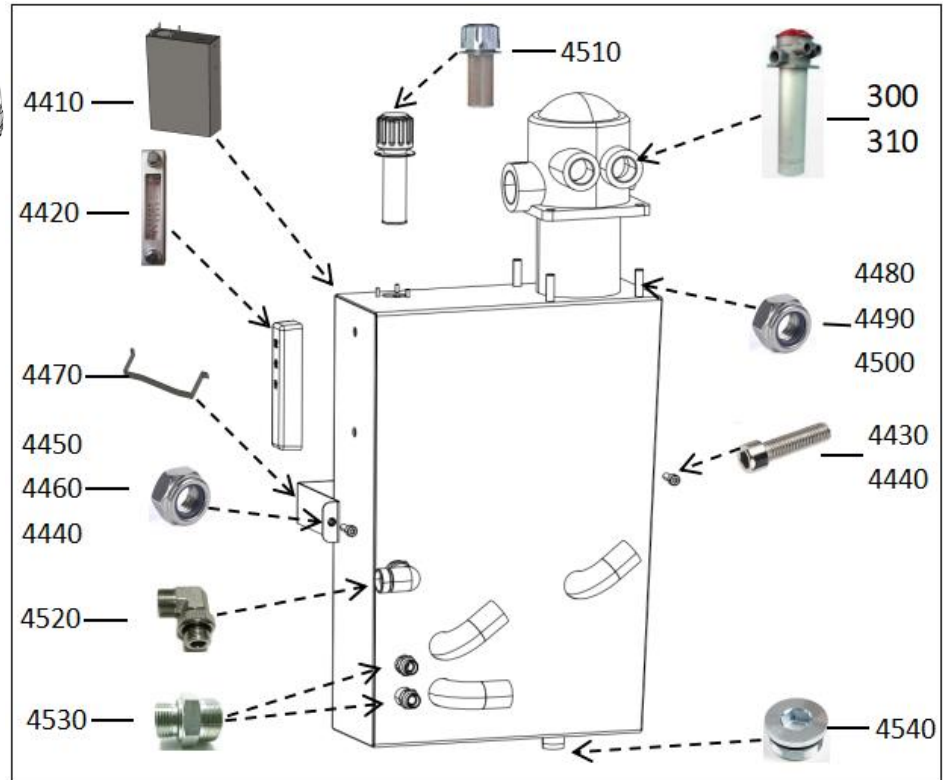
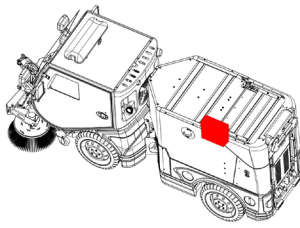

No.	Picture	Description	Material Code	Quantity
4340		Hexagonal socket countersunk head cap head screw	M6*20	8
4350		Nylon locking nut	M6	4
4360		Left outer large protective panel of water tank	RG8240 · 4 · 16.1	1
4370		Lock button	B071	2
4380		Fixed base of air filter	RG8240 · 4 · 12	1
4390		Right outer large protective panel of water tank	RG8240 · 4 · 16.2	1
4400		Right outer small protective plate of water tank	RG8240 · 4 · 18.2	1





No.	Picture	Description	Material Code	Quantity
-----	---------	-------------	---------------	----------

4410		Right welded fuel tank	RG · 3500 · 28 · 14	1
------	---	------------------------	---------------------	---

4420		Liquid level gauge	B070	1
------	---	--------------------	------	---

4430		Hexagon socket head screw	M8*25	2
------	---	---------------------------	-------	---

4440		Washer	D8	4
------	---	--------	----	---

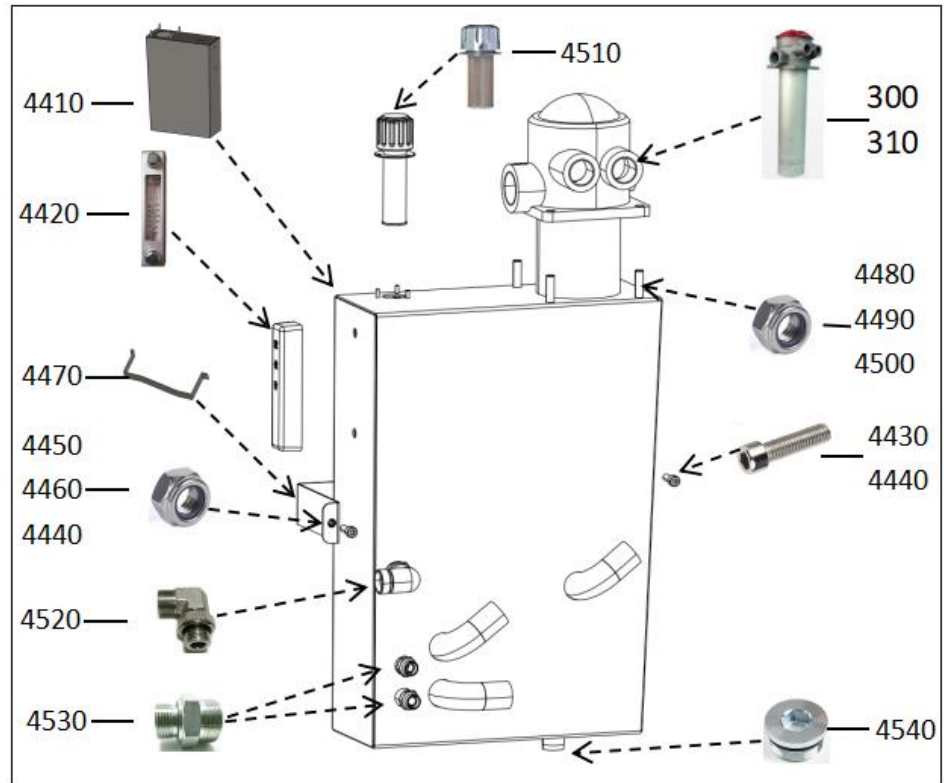
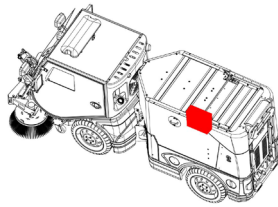

4450		Nylon locking nut	M8	2
------	---	-------------------	----	---

4460		Spring washer	D8	2
------	---	---------------	----	---

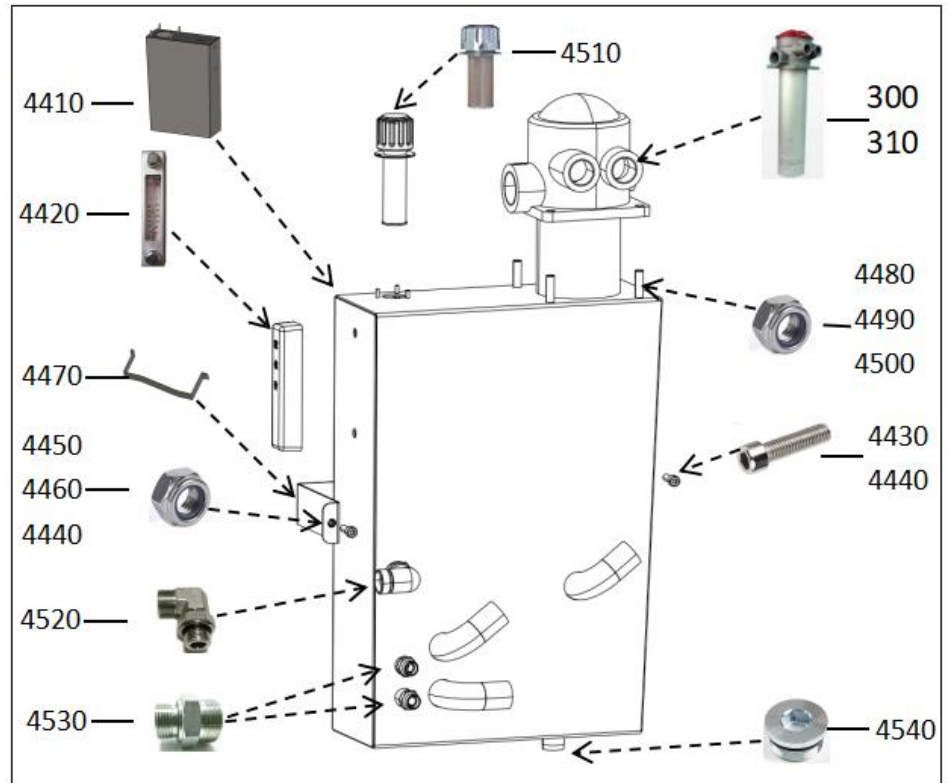
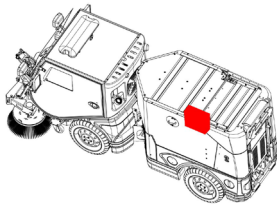

No.	Picture	Description	Material Code	Quantity
4470		Fixed plate of right hydraulic oil tank	RG · 8240 · 4 · 38	1
4480		Nylon locking nut	M10	2
4490		Spring washer	D10	2
4500		Washer	D10	4
4510		Air filter	B027-0	1
4520		Pipe joint	1CG9-30-120G	1



No.	Picture	Description	Material Code	Quantity
4530		Pipe joint	1CB-18-06WD	2
4540		Plug	4BN-08WD	1

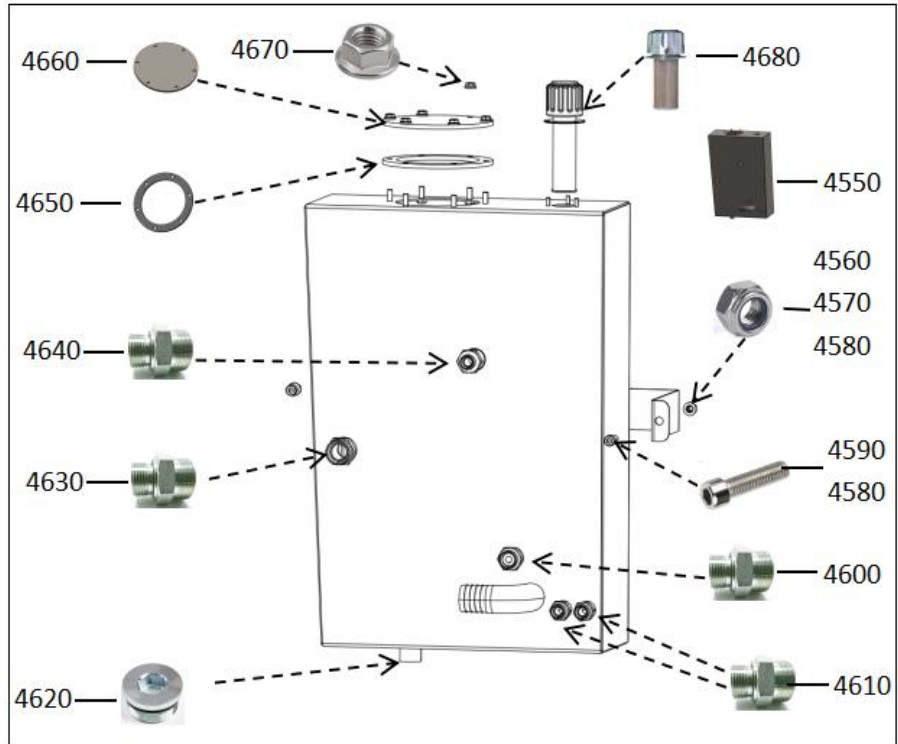
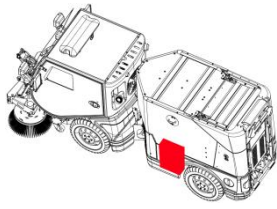

No.	Picture	Description	Material Code	Quantity
4550		Left welded fuel tank	RG · 3500 · 28 · 1	1
4560		Nylon locking nut	M10	2
4570		Spring washer	D10	2
4580		Washer	D10	4
4590		Hexagon socket head screw	M8*25	2
4600		Pipe joint	1CB-22-08WD	1

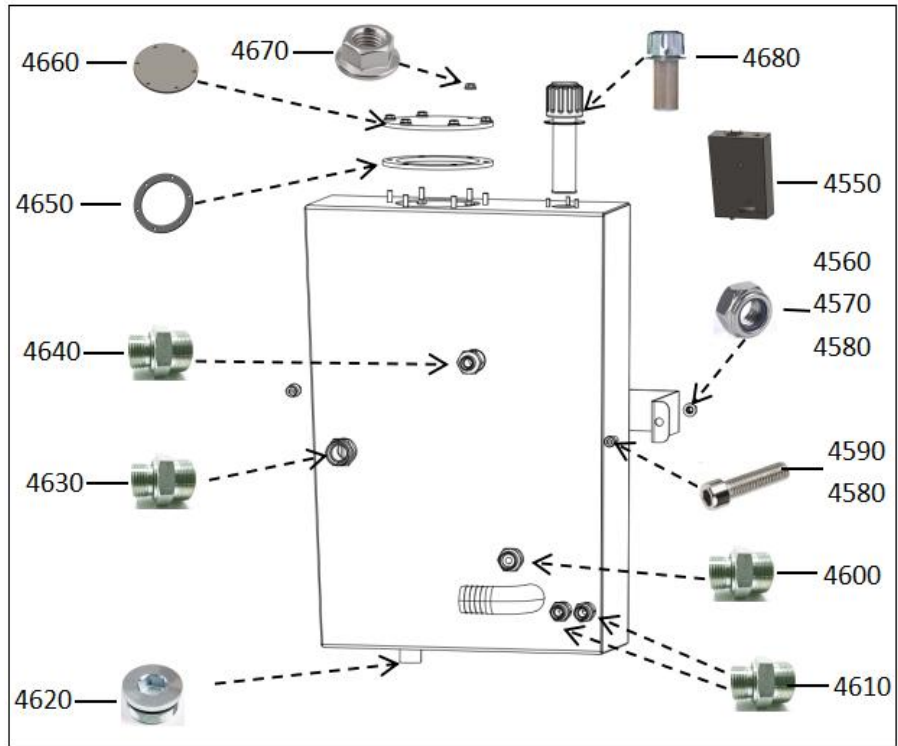
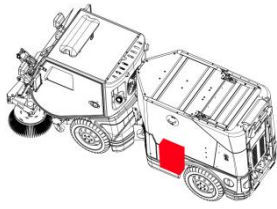

No.	Picture	Description	Material Code	Quantity
4610		Pipe joint	1CB-18-06WD	2
4620		Plug	4BN-08WD	1
4630		Pipe joint	1CB-30-12WD	1
4640		Pipe joint	1CB-18-08WD	1
4650		Sealing gasket	06.P011	1
4660		Cover plate of hydraulic oil tank	RG · 3500 · 28 · 18	1

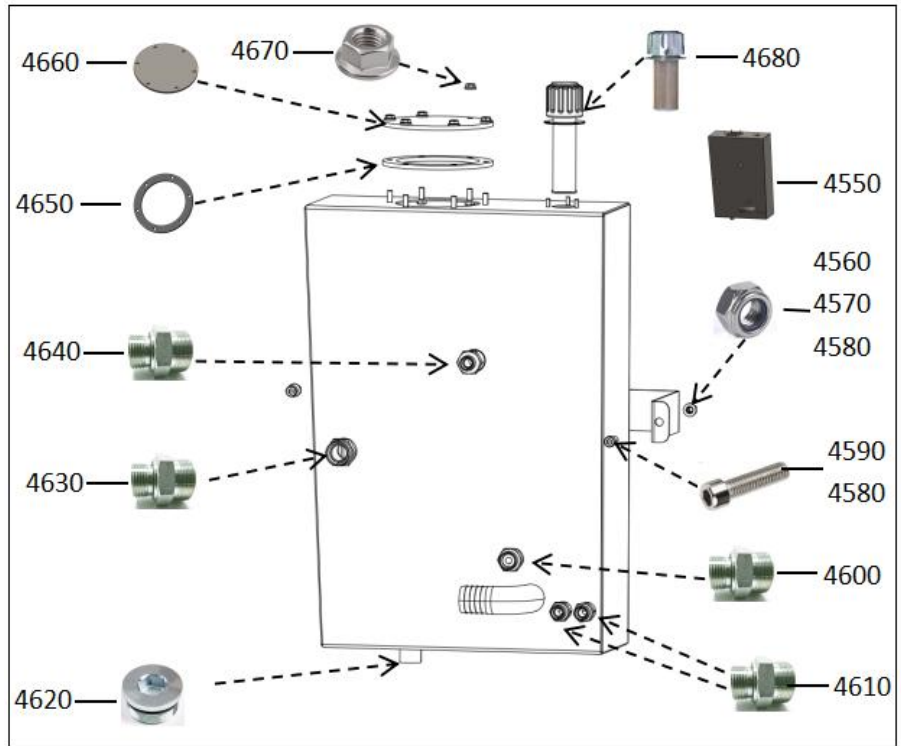
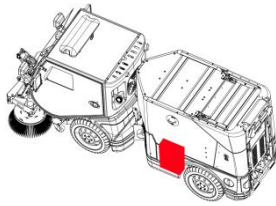

No.	Picture	Description	Material Code	Quantity
-----	---------	-------------	---------------	----------



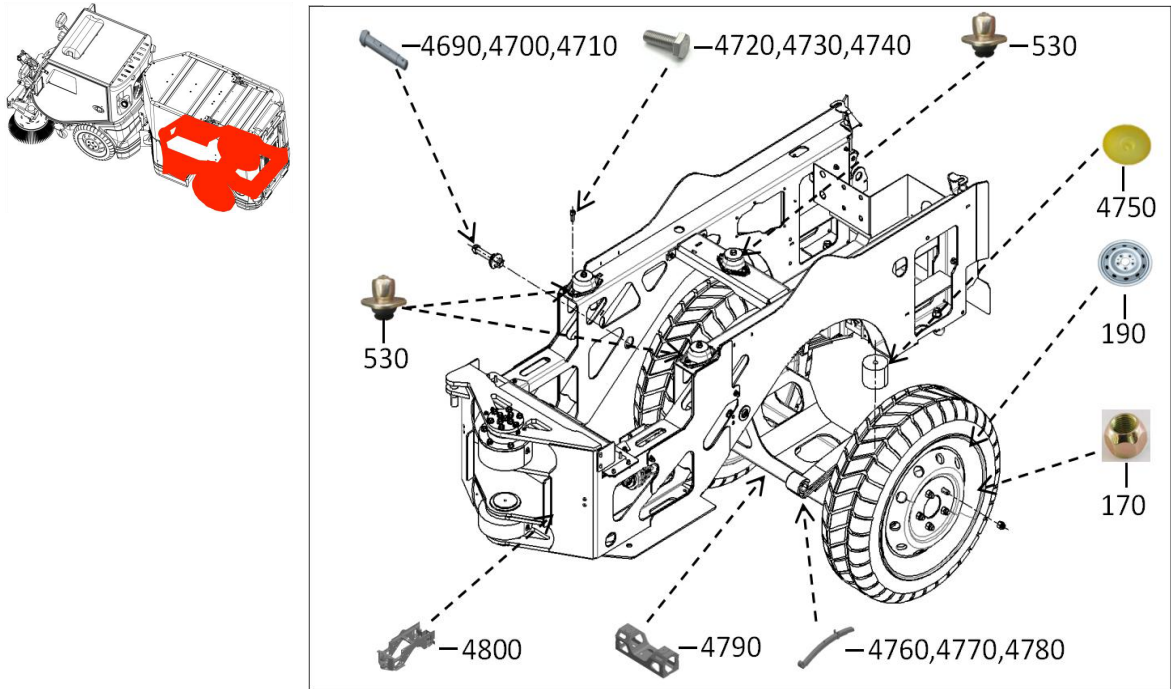

4670		Flange nut	M6	6
------	---	------------	----	---

4680		Air filter	B027-0	1
------	---	------------	--------	---

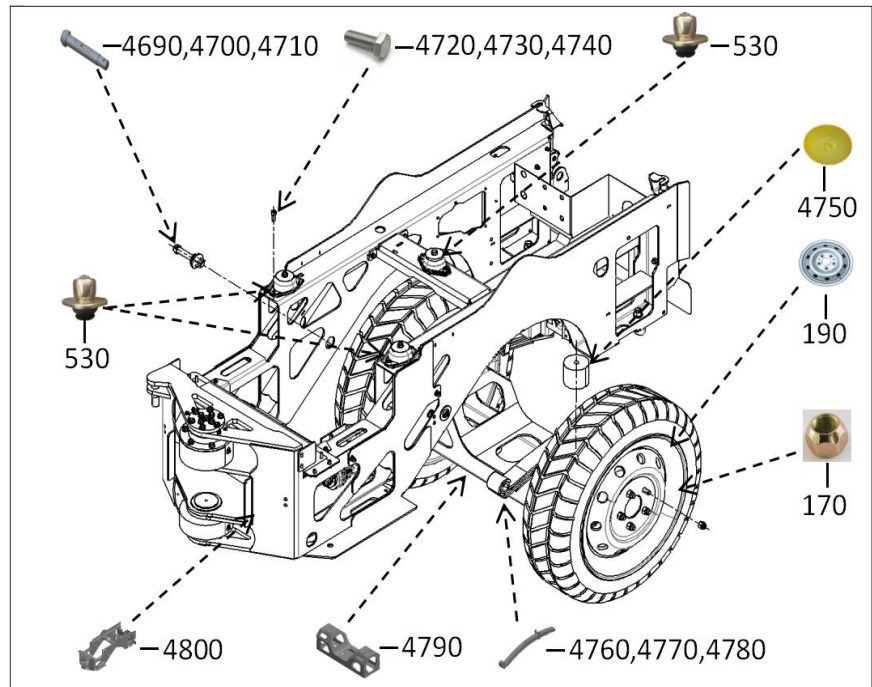
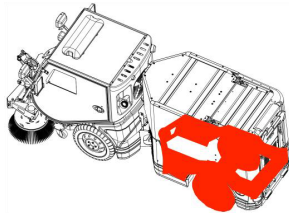

No.	Picture	Description	Material Code	Quantity
4690		Slotted nut	M18	2
4700		Split pin $\varnothing D4*35$	D616	2
4710		Leaf spring pin	A007-03	2
4720		Hexagonal head full thread bolt	M10*25	6
4730		Spring washer	D10	6
4740		Flat washer	D10	6



No.	Picture	Description	Material Code	Quantity
4750		Spring steel rubber pad	A065-01/02	2
4760		Spring steel plate assembly	A035	2
4770		Leaf spring fixing parts	A034	4
4780		Nylon locking nut	M16	8
4790		Fixed base of rear walking motor	RG · 8240 · 4 · 6	1
4800		Rear bracket	RG · 8240 · 4 · 1	1

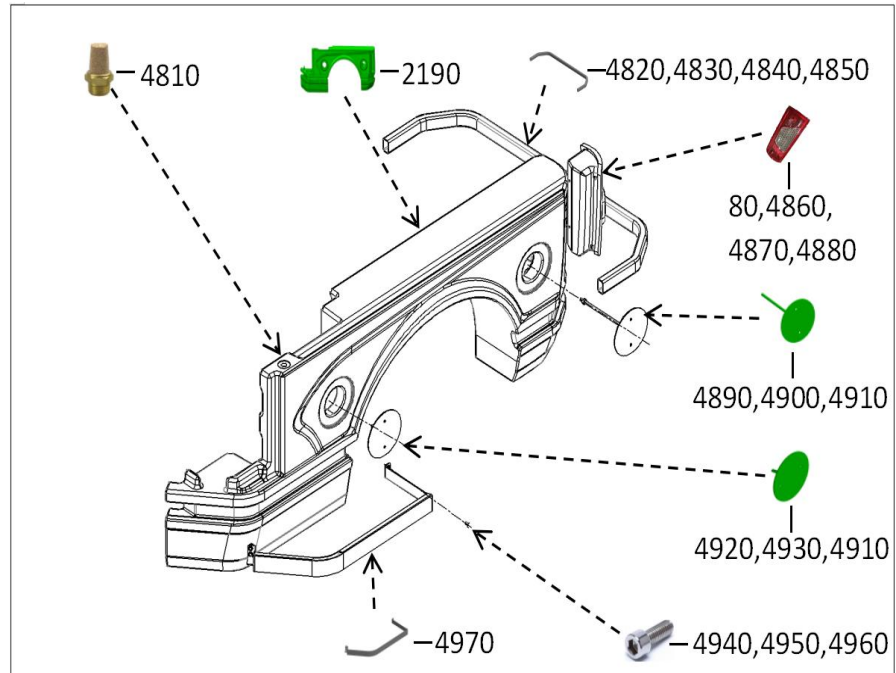
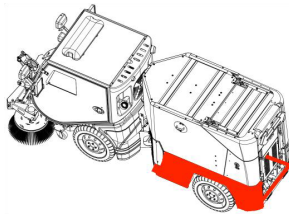



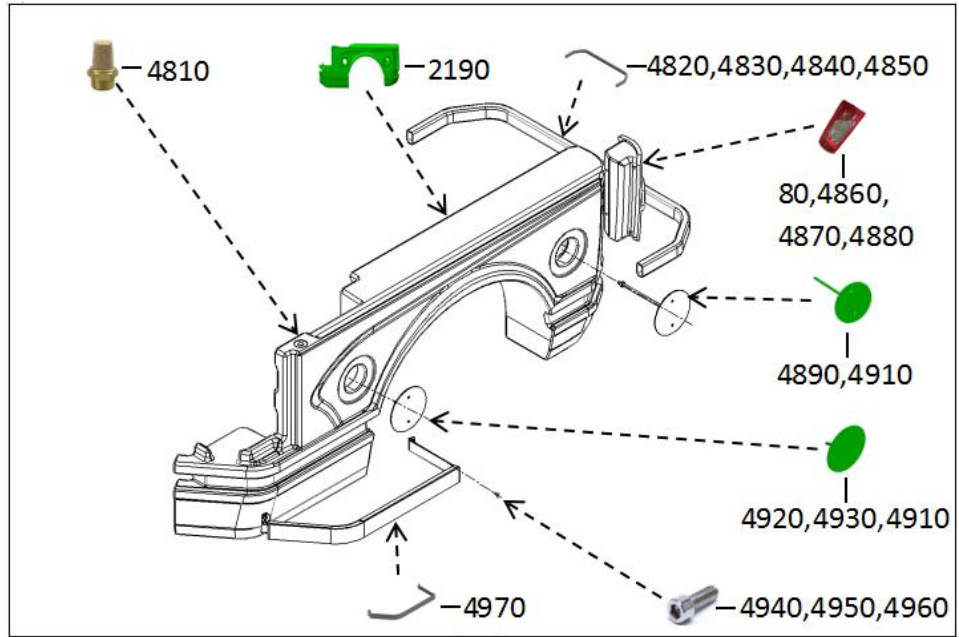
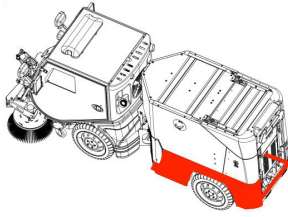

No.	Picture	Description	Material Code	Quantity
4810		Muffler	E012	1
4820		Rear bumper	A025-13	1
4830		Internal hexagonal socket head full thread screw	M10*30	4
4840		Spring washer	D10	4
4850		Extra large Flat washer	D10	4
4860		Flange nut	M5	2

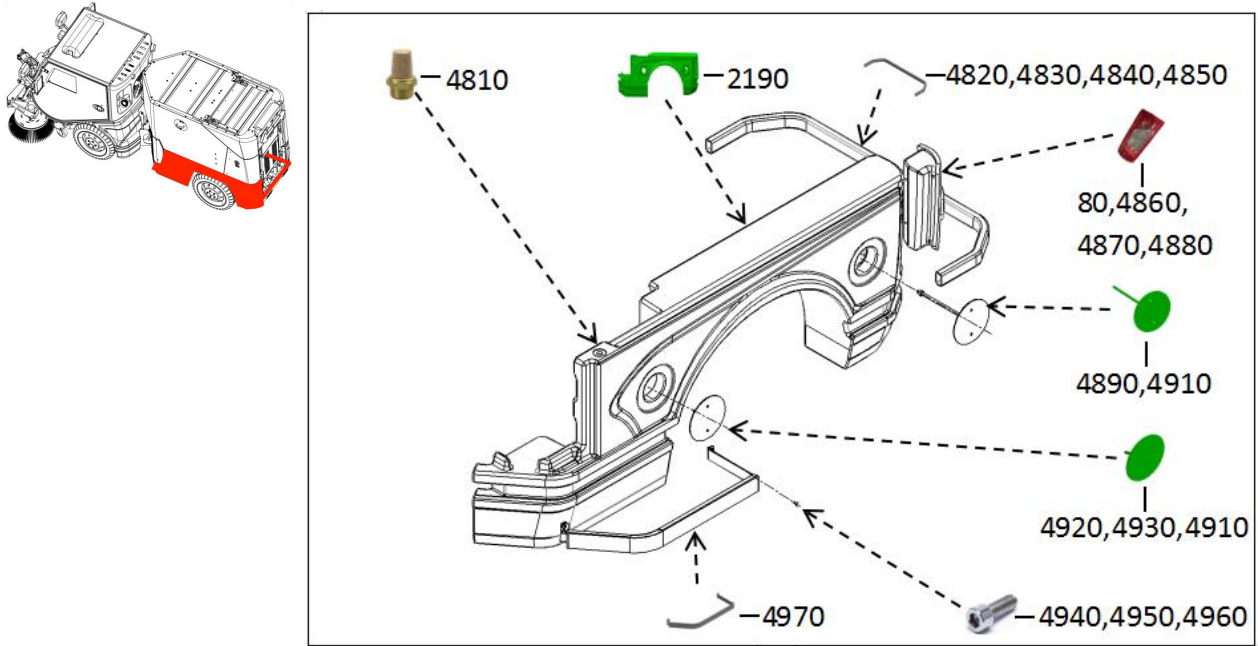

No.	Picture	Description	Material Code	Quantity
4870		Tail light fixing plate	RG · 8240 · 4 · 34	2
4880		Oversized Flat washer	D5	2
4890		Left water tank rear protection plate	RG · 8240 · 4 · 46	1
4910		Nylon locking nut	M10	2
4920		Left water tank front protection plate	RG · 8240 · 4 · 45	1
4930		Water tank protective plate	RG · 8240 · 4 · 45 · 1	1



No.	Picture	Description	Material Code	Quantity
4940		Internal hexagonal socket head full thread screw	M8*25	4
4950		Spring washer	D8	4
4960		Flat washer	D8	4
4970		Left water tank bumper	A025-13	1

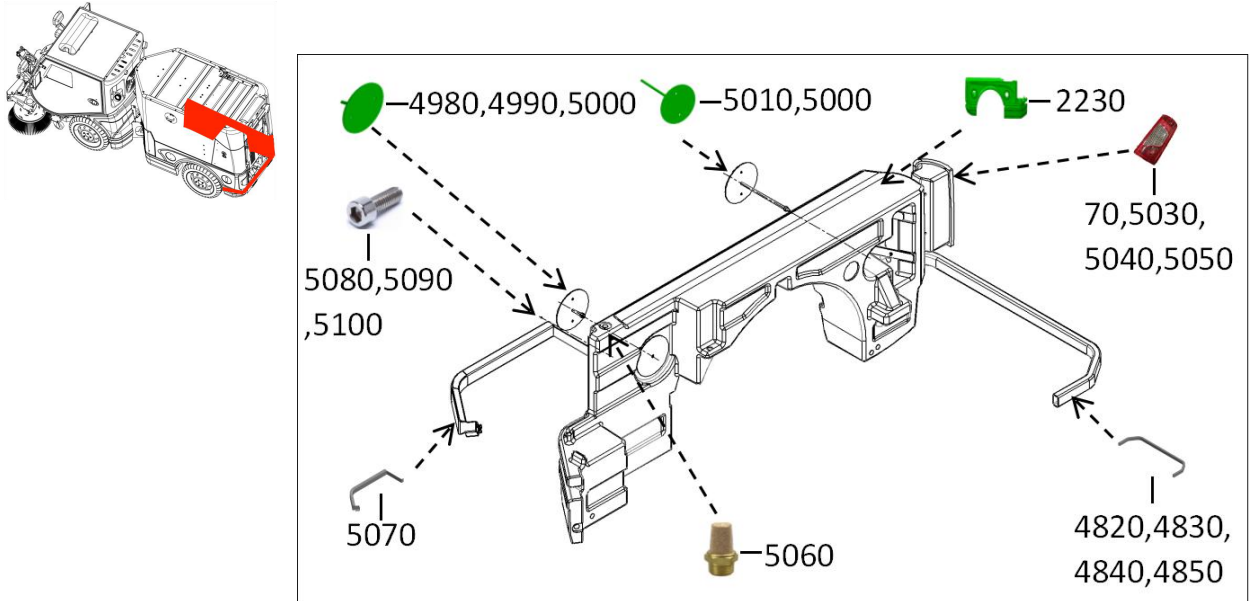

No.	Picture	Description	Material Code	Quantity
4980		Front protection plate of water tank	RG · 8240 · 4 · 45	1
4990		Front baffle of right water tank	RG · 8240 · 4 · 45 · 1	1
5000		Nylon locking nut	M10	2
5010		Water tank rear protection plate	RG · 8240 · 4 · 46	1
5030		Flange nut	M5	2
5040		Tail light fixing plate	RG · 8240 · 4 · 34	2

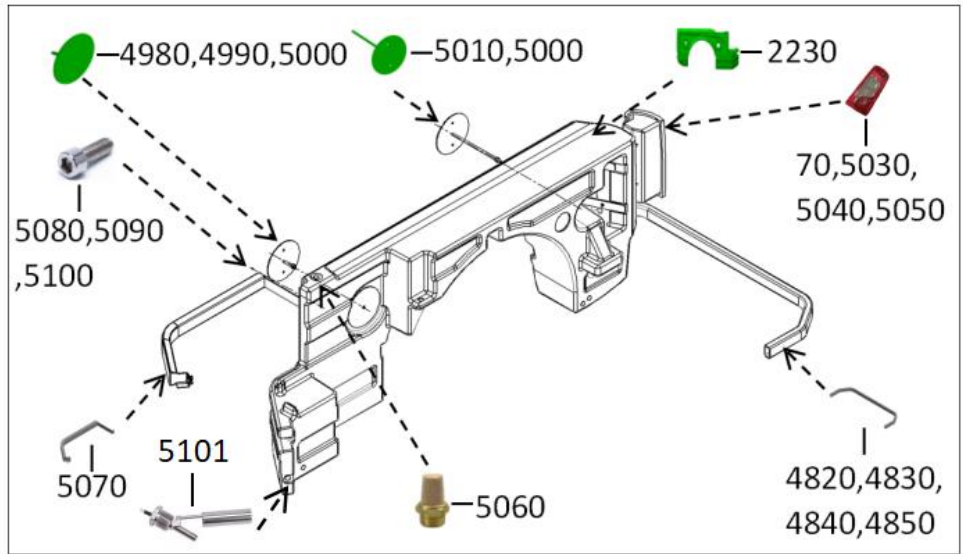
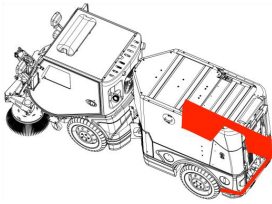

No.	Picture	Description	Material Code	Quantity
5050		Oversized Flat washer	D5	2
5060		Muffler	E012	1
5070		Right water tank bumper	A025-13	1
5080		Internal hexagonal socket head full thread screw	M8*25	4
5090		Spring washer	D8	4
5100		Flat washer	D8	4
5101		Water level sensor	B039	1

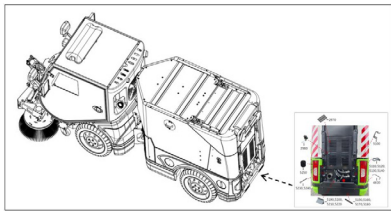

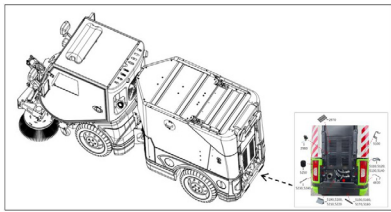

No.	Picture	Description	Material Code	Quantity
5110		Left card board of recycling bin lock rod	RG · 8240 · 4 · 22	2
5120		Recycling box lock rod card plate fixing plate	RG · 8240 · 4 · 21	2
5130		Internal hexagonal socket head full thread bolt	M6*25	2
5140		Spring washer	D6	4
5150		Oversized Flat washer	D6	2
5160		Fixing plate of number plate	RG · 8240 · 4 · 35	1



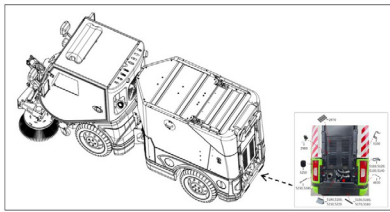



No.	Picture	Description	Material Code	Quantity
5170		Internal hexagonal socket head full thread bolt	M6*25	2
5180		Flat washer	D6	2
5190		Rear guard board of battery	RG · 8240 · 4 · 8	1
5200		Internal hexagonal socket head full thread bolt	M8*25	2
5210		Spring washer	D8	2
5220		Flat washer	D8	2

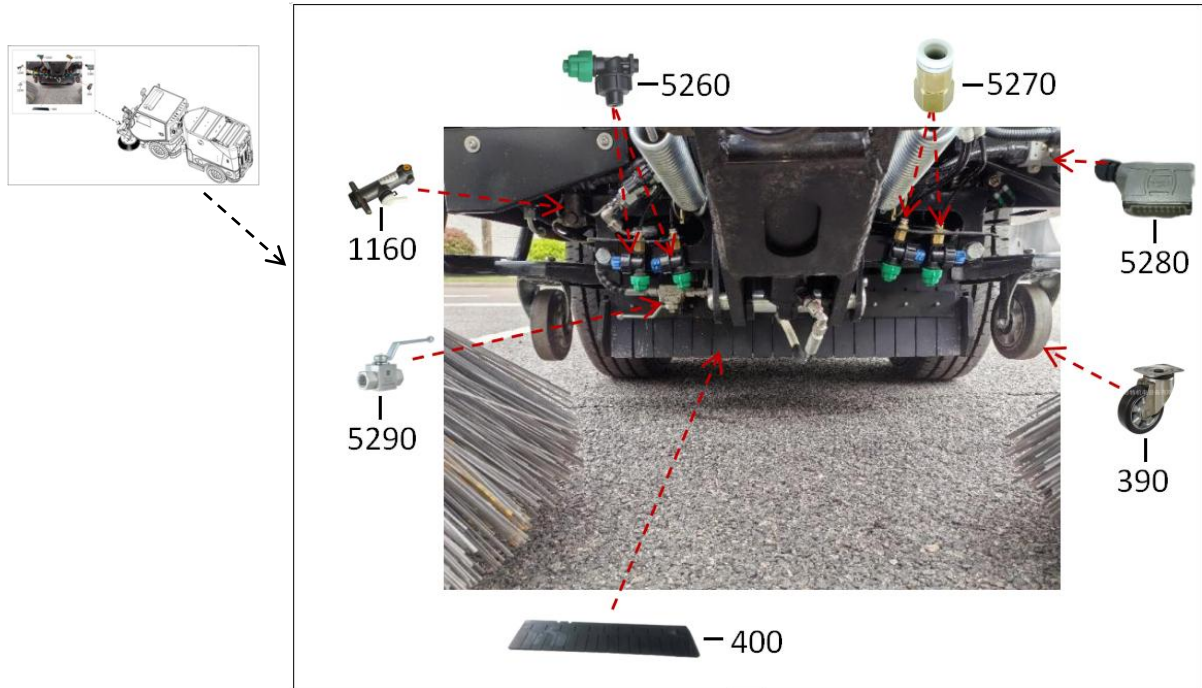

No.	Picture	Description	Material Code	Quantity
5230		Eyelet bolt	E066	2
5240		Nylon locking nut	M20	2
5250		Rubber cap	A001-74	2



No.	Picture	Description	Material Code	Quantity
5260		Sweeping nozzle with switch	06.A081	4
5270		Brass quick coupling	E002	4
5280		16 core aviation connector	006.L008	1
5290		Handle ball valve	B018	1

Professional road sweeper manufacturing enterprise

Making cleaning simple

+90 533 773 65 79

SERPARK MAKİNE SANAYİ VE DIŐ TİCARET LTD.

Mansurođlu Mah. 288/4 Sok. A Blok No:9/1 K:2 D:27 Bayraklı 35535 İzmir - Türkiye

T: +90 232 969 72 55

E-mail: info@serpark.com

www.serpark.com

